

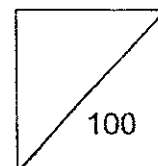

HENRY PARK PRIMARY SCHOOL
2014 SEMESTRAL EXAMINATION 1
SCIENCE
PRIMARY 4



Duration of Paper: 1 h 45 min

Name: _____

Class: Pr 4 _____

Parent's Signature: _____

Booklet A (60 marks)

For each question from 1 to 30, four options are given. One of them is the correct answer.
Make your choice (1, 2, 3 or 4). Shade the correct oval (1, 2, 3 or 4) on the Optical Answer Sheet.

1. Which of the following is **NOT** matter?

- A: Ice
- B: Heat
- C: Sunlight

- (1) B only
- (2) A and B only
- (3) A and C only
- (4) B and C only

()

2. Which of the following is **NOT** a source of heat?

- (1) The Sun
- (2) A raincoat
- (3) A lighted lamp
- (4) A burning candle

()

3. Karen filled a beaker with two substances, **A** and **B**.

She placed it on a wooden wedge as shown below.

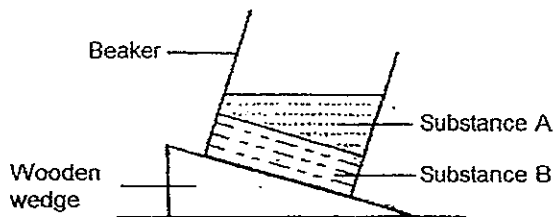

She then removed the wooden wedge and left the beaker on the table.

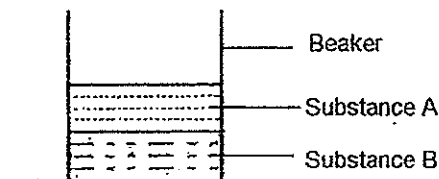

What states are Substances **A** and **B** in?

	A	B
(1)	Solid	Liquid
(2)	Solid	Gas
(3)	Liquid	Solid
(4)	Liquid	Gas

()

4. The diagram below shows how food travels in our body during digestion.

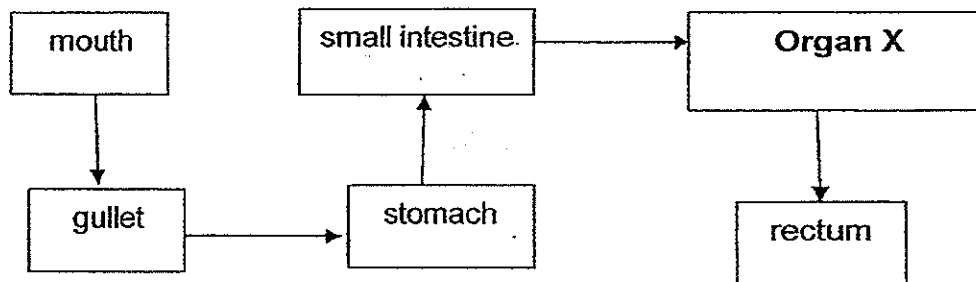

Which of the following shows the function of Organ X?

- (1) It breaks down food into a soupy liquid.
- (2) It removes water from the undigested food.
- (3) It absorbs digested food into the blood vessels.
- (4) It churns and mixes the food with digestive juices.

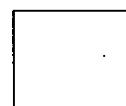

()

Four girls, Mary, Doris, Nora and Susan, made the following statements about the three bags shown below.

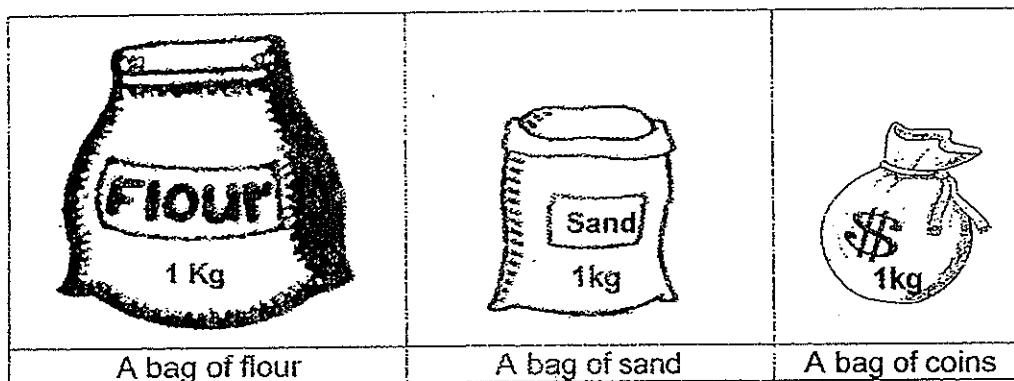

- Mary: The items in the three bags have different mass.
 Doris: The items in the three bags have the same mass.
 Nora: The three bags of substances have different volume.
 Susan: The three bags of substances have the same volume.

Whose statements are correct?

- (1) Nora and Mary only
- (2) Doris and Nora only
- (3) Mary and Susan only
- (4) Doris and Susan only

()

The diagram below shows the volume of liquid X.

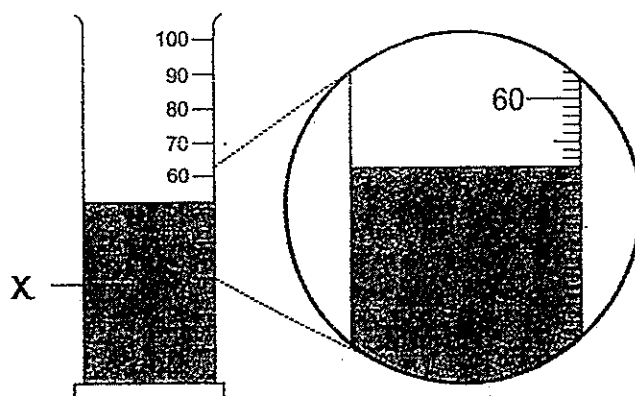

Which of the following shows the **correct** volume of liquid X?

- (1) 50 ml
- (2) 52 ml
- (3) 61 ml
- (4) 68 ml

()



7. Jack filled the syringe with equal volume of air and water.
He placed his finger at one end of the syringe tightly as shown below.

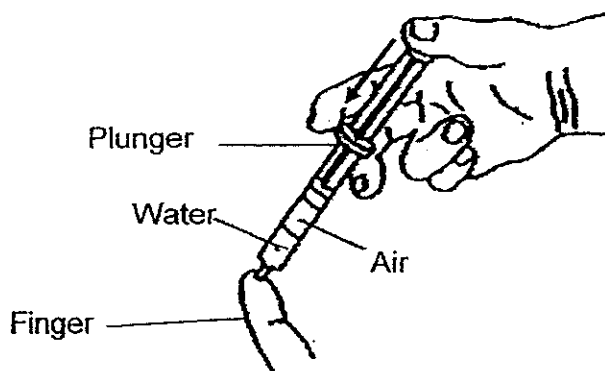

Which one of the following is observed when the plunger is pushed in?

	Volume of water	Volume of air
(1)	Remains the same	Remains the same
(2)	Increases	Decreases
(3)	Remains the same	Decreases
(4)	Decreases	Remains the same

8. Study the classification chart below.

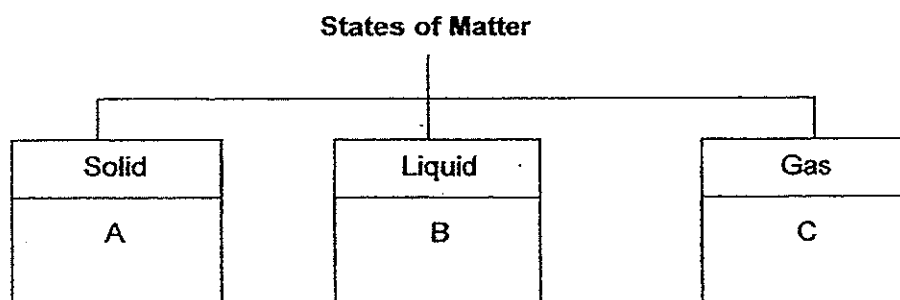

Which of the following box(es) should we place an ice cube in?

- (1) A only
(2) B only
(3) A and C only
(4) B and C only

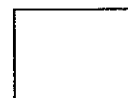

9. John pumped air into a deflated ball and then measured its mass as shown in diagram A.

More air is then pumped into the ball and its mass is measured as shown in diagram B

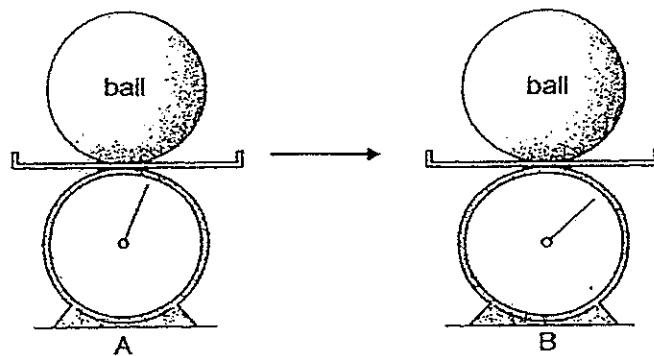

What can John observe from this experiment?

- A: Air has mass.
- B: Air occupies space.
- C: Air can be compressed.

- (1) A only
- (2) A and B only
- (3) B and C only
- (4) A, B and C

()

10. Three pupils learning about human systems made the following statements.

Alice: The digestive system helps to break down food so that the body can use it.

X Bobby: The circulatory system moves water and nutrients around the body.

✓ Cassie: The respiratory system helps to take in carbon dioxide and remove oxygen from the body.

Whose statement(s) is/are correct?

- (1) Alice only
- (2) Cassie only
- (3) Alice and Bobby only
- (4) Cassie and Bobby only

()



11. The flowchart below shows the properties of X, Y and Z.

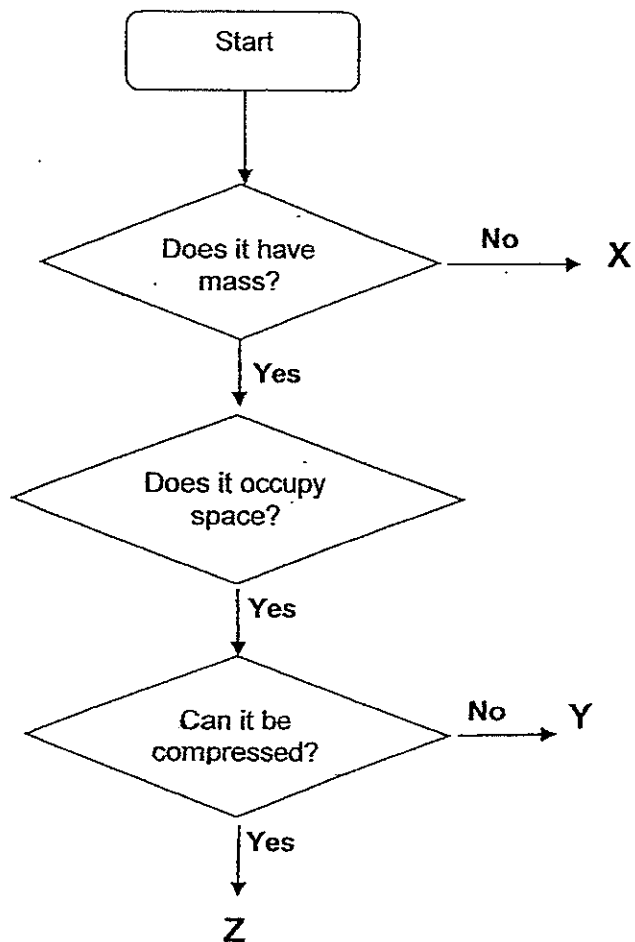

Which one of the following correctly identifies X, Y and Z?

	X	Y	Z
(1)	Heat	Water	Oxygen
(2)	Oil	Oxygen	Marble
(3)	Marble	Oil	Water
(4)	Heat	Marble	Oil

()



2. Nadia poured water into a beaker through the funnel with plasticine fitted tightly on the beaker.

She observed that the water flowed into the beaker slowly and then stopped.

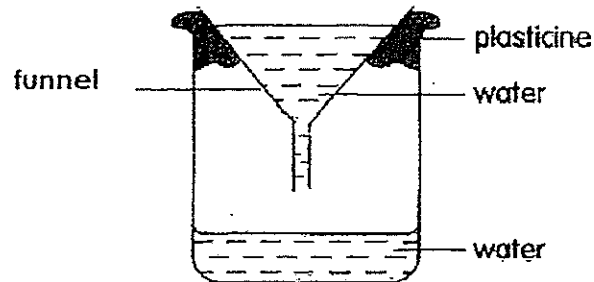

What should Nadia do so that the water can flow into the beaker quickly?

- (1) Nadia should use a smaller beaker.
- (2) Nadia should add more water to the funnel.
- (3) Nadia should poke a hole through the plasticine.
- (4) Nadia should remove some water from the funnel.

()

3. The graph below shows the changes in temperature of water in a beaker when it was heated for 5 minutes.

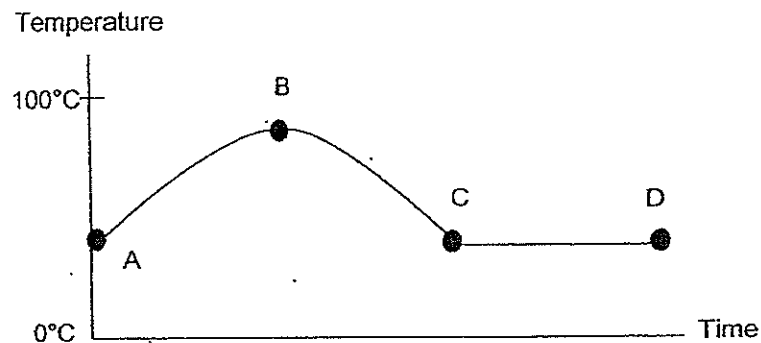

The room temperature where the beaker was heated is 30°C.

At which point of the graph, A, B, C or D, is the heat source removed?

- (1) A
- (2) B
- (3) C
- (4) D

()



14. Amran boiled some water using the pot shown below.

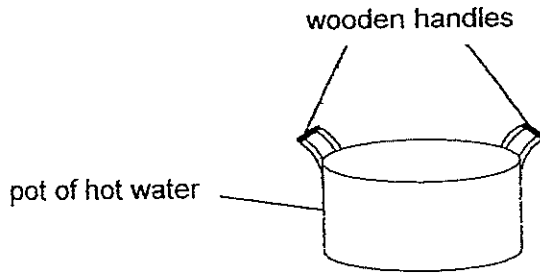

He is able to hold the pot of hot water by the handles because the material used to make the handles is _____.

- (1) light
- (2) flexible
- (3) a poor conductor of heat
- (4) a good conductor of heat

()

15. Ali poured some cold milk into a cup of hot tea he has prepared as shown below.

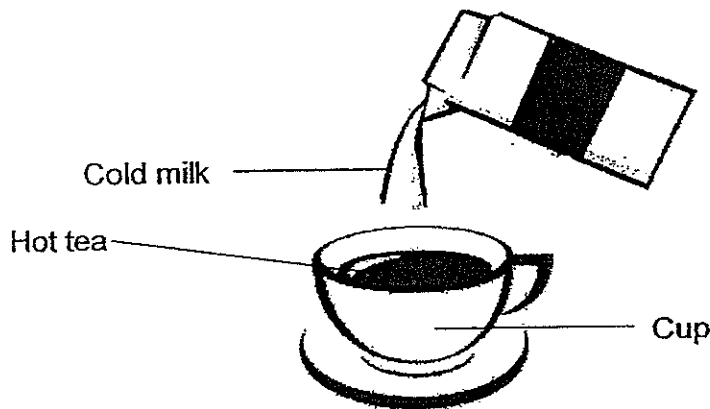

Which of the following about heat gain and heat loss is correct after the cold milk is added to the cup of hot tea?

	Heat Gained	Heat Lost
(1)	Cup	Cold milk
(2)	Hot tea	Cold milk
(3)	Hot tea	Cup
(4)	Cold milk	Hot tea

()

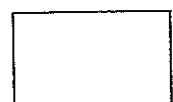

16. James poured an equal amount of boiling water into four cups, W, X, Y and Z, which were made of different materials.

Then he covered them and recorded their temperatures after 30 minutes.

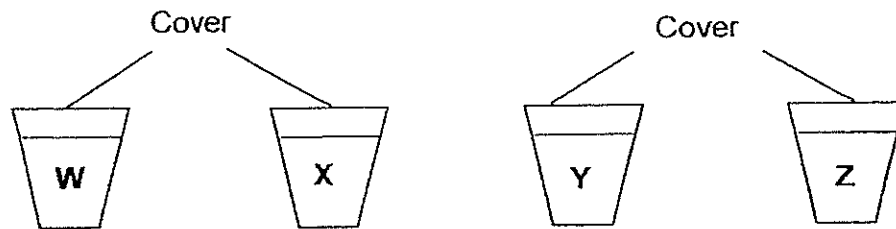

The results were shown in the graphs below.

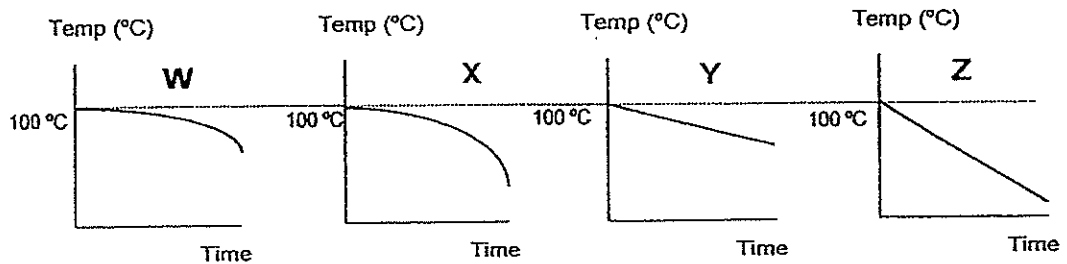

Based on the results shown above, which cup, W, X, Y or Z is made of a material that is the **best** conductor of heat?

- (1) W
- (2) X
- (3) Y
- (4) Z

()

17. Which one of the following differences between animals and ferns is **NOT** correct?

	Animals	Ferns
(1)	Cannot make their own food	Can make their own food
(2)	Need water	Do not need water
(3)	Is not a plant	Is a plant
(4)	Do not reproduce using spores	Reproduce using spores

()



18. Look at the pictures below.

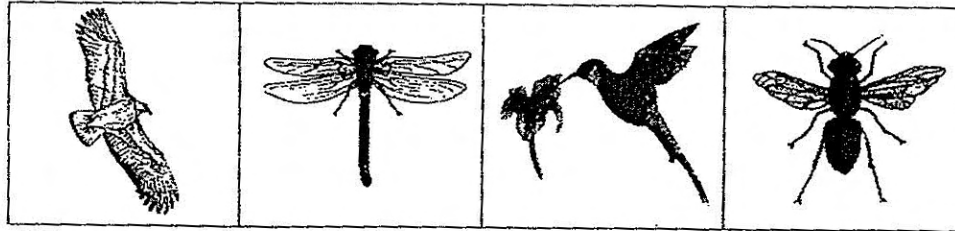

In what way are the above animals similar?

- (1) They have wings
- (2) They have 2 legs
- (3) They have feelers
- (4) They have feathers

()

19. Mr Tan filled a basin with hot water. He put several dented ping pong balls into it.

After a while, all but one ping pong ball became inflated.

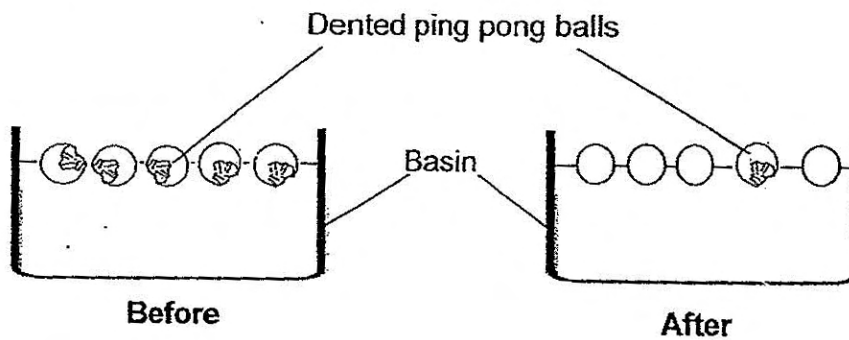

Why was the ball still dented?

- (1) There is no air in the ball.
- (2) The air in the ball lost heat and contracted.
- (3) The air in the ball gained heat and contracted.
- (4) There was a hole in the ball so the air escaped through it.

()



20. Jordan carried out an experiment to find out which cup will keep a drink warm the longest period of time.

He poured an equal amount of hot coffee into three cups, X, Y and Z, each made of a different material.

He then recorded the temperature of the coffee in each cup every five minutes as shown in the table below.

Time (Min)	Temperature of coffee in cups (°C)		
	X	Y	Z
0	85	85	85
5	81	79	77
10	78	75	72
15	75	72	68
20	72	67	62

Based on the table above, the coffee in cup _____

- (1) X lost heat the fastest.
- (2) Z lost heat the slowest.
- (3) X took the longest time to reach 72°C.
- (4) Z took the longest time to reach 72°C.

()

21. Study the chart below.

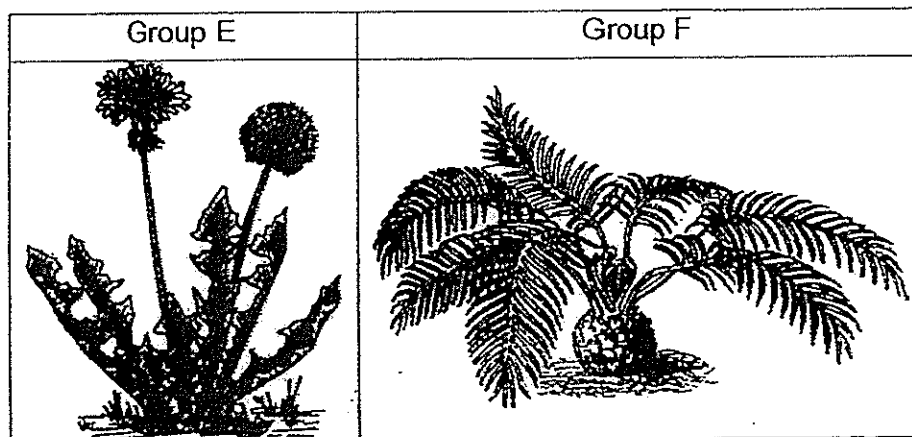

Which one of the following makes a suitable heading for Group E and Group F?

	Group E	Group F
(1)	land plant	water plant
(2)	poisonous plant	non-poisonous plant
(3)	flowering plant	non-flowering plant
(4)	non-flowering plant	flowering plant

()

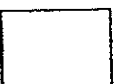

22. Each of the four rods, P, Q, R and S, was put into a container with icy cold water at 5°C . Each rod was made of a different material.

After 15 minutes, the temperature at the other end of each rod was measured.

The results of the temperature are shown in the diagram below.

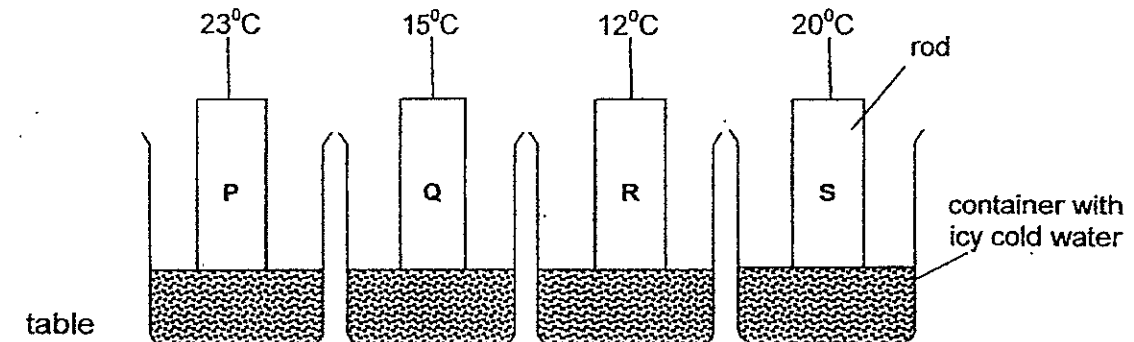

The temperature of each rod was 28°C at the **start** of the experiment.

Which rod is made of a material that is the **poorest** conductor of heat?

- (1) P
- (2) Q
- (3) R
- (4) S

()

23. The diagram below shows Organism X.

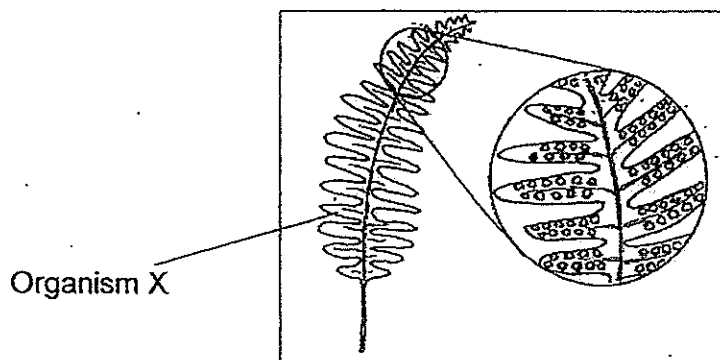

Which of the following statements is **correct** about Organism X?

- (1) It bears fruits.
- (2) It bears flowers.
- (3) It makes its own food.
- (4) It feeds on dead organisms.

()



f. Look at the pictures below.

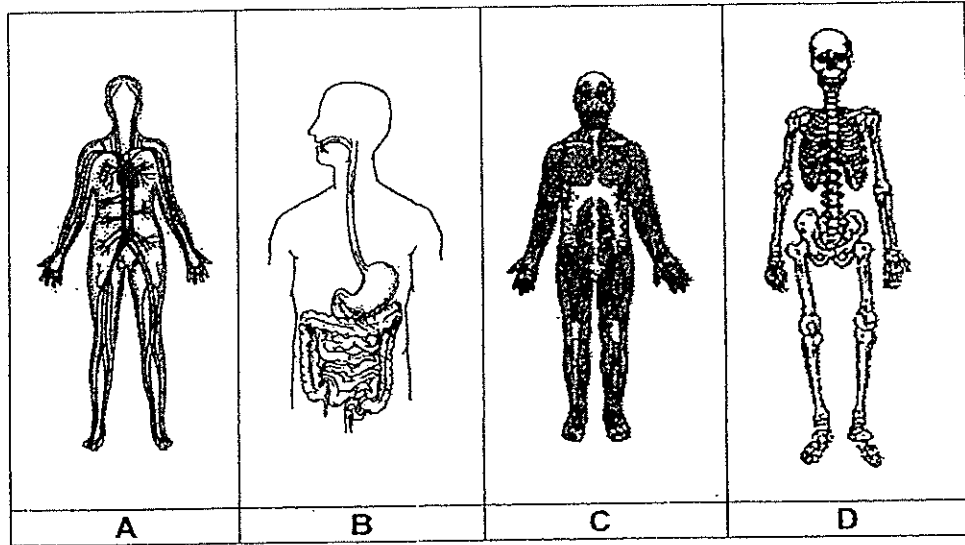

Which system, A, B, C or D, helps to carry oxygen to all parts of the body?

- (1) A
- (2) B
- (3) C
- (4) D

The diagram below shows two children running together.

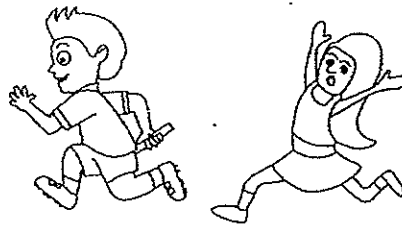

Which two body systems work together to allow the children to move?

- A: Skeletal System
- B: Muscular System
- C: Respiratory System
- D: Circulatory System

- (1) A and B only
- (2) A and C only
- (3) B and D only
- (4) C and D only

26. The chart below shows organs A, B, C and D as food passes through the human digestive system.

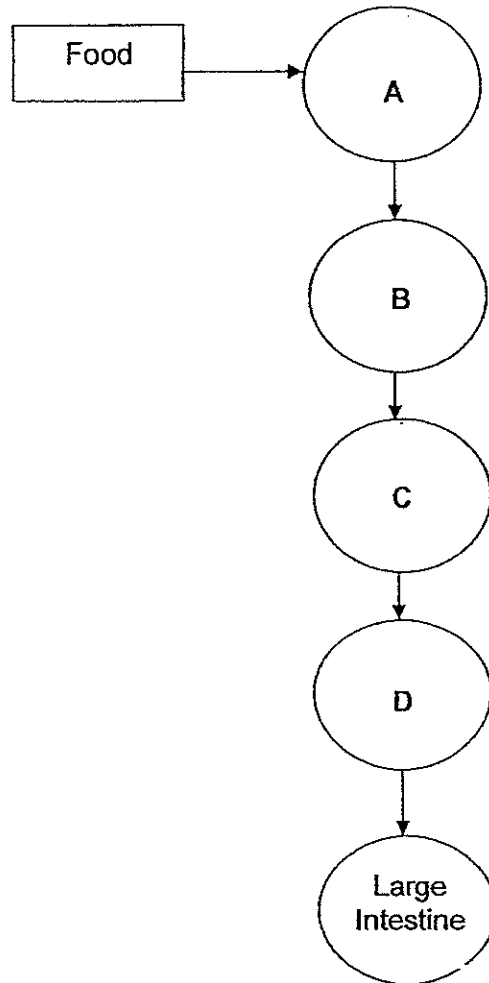

Which one of the following represents Organs C and D?

	Organ C	Organ D
(1)	Gullet	Mouth
(2)	Small Intestine	Gullet
(3)	Mouth	Stomach
(4)	Stomach	Small Intestine

7. Look at the diagram of a mouth below.

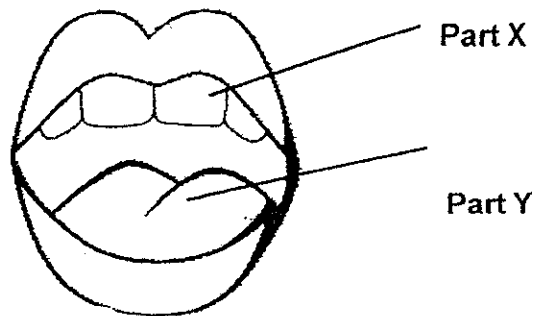

Which of the statements below describe the functions of **Part X** and **Part Y** correctly?

	Part X	Part Y
(1)	Breaks down food into soupy liquid	Moisten and soften the food.
(2)	Breaks down large food pieces into smaller ones.	Pushes the food around the mouth
(3)	Breaks down food and pushes food to the gullet.	Helps to squeeze the food along the gullet.
(4)	Breaks down and absorbs water from food.	Rolls food into balls for easy swallowing.

A young plant was placed in a thick cardboard box.

Four holes **A**, **B**, **C** and **D**, were made on the sides of the box as shown below.

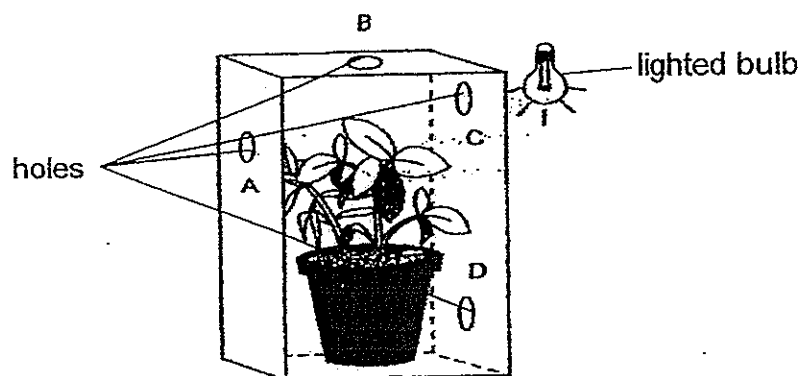

Which one of the holes would the plant **most likely** grow towards?

- (1) A
- (2) B
- (3) C
- (4) D

29. Idris has three rods labelled A, B and C.

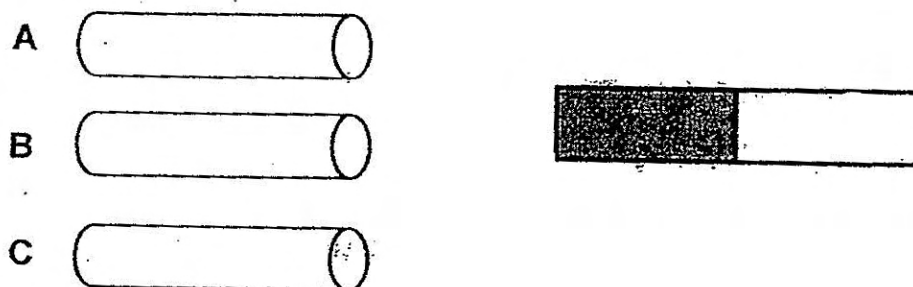

He carried out an experiment by bringing part X of a bar magnet near each end of the three rods, A, B and C, as shown above.

He then recorded his results in the table below.

Rod	Observation
A	Both ends of Rod A are attracted to part X of the bar magnet.
B	One end of Rod B is attracted to part X of the bar magnet while the other end repelled.
C	Both the ends of Rod C are not attracted to part X of the bar magnet.

Which of the following statements about rods A, B and C is likely to be correct?

- (1) Rod B is a magnet.
- (2) Rod C is a temporary magnet.
- (3) Both Rod A and Rod B are magnets.
- (4) Both Rod A and Rod C are made of magnetic materials.

()

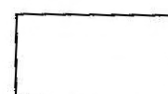

30. Elle wanted to find out the strength of four bar magnets, **P**, **Q**, **R** and **S**.

She placed each magnet 10 cm from an iron nail and moved the magnet slowly towards the iron nail.

She then measured and recorded the distance from which each magnet attracted the iron nail.

Magnet	Distance between the magnet and the iron nail when the iron nail was attracted to the magnet (cm)
P	5
Q	8
R	4
S	2

Based on her results above, which bar magnet is the **strongest**?

- (1) Magnet P
- (2) Magnet Q
- (3) Magnet R
- (4) Magnet S

~ End of Booklet A ~

HENRY PARK PRIMARY SCHOOL
2014 SEMESTRAL EXAMINATION 1
SCIENCE
PRIMARY 4

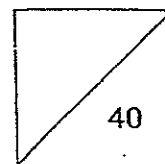

Name: _____

Class: Pr 4 _____

Booklet B (40 marks)

For each question from 31 to 44, write your answers in the spaces given.

31. Two similar cups, A and B, were inverted into a basin of water.
One of them had holes at its base.

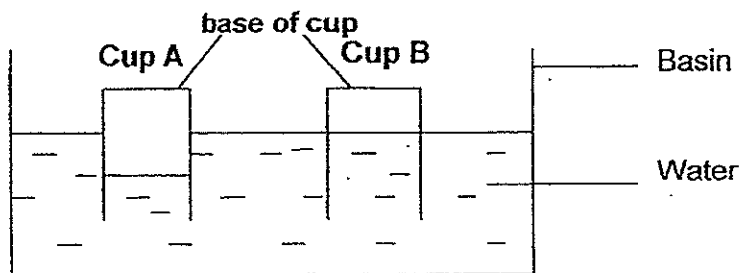

- a) Based on the diagram above, which cup had holes at its base? [1m]

- b) Give a reason for your answer in (a). [2m]



32. The classification chart below shows how substances X, Y and Z are being grouped.

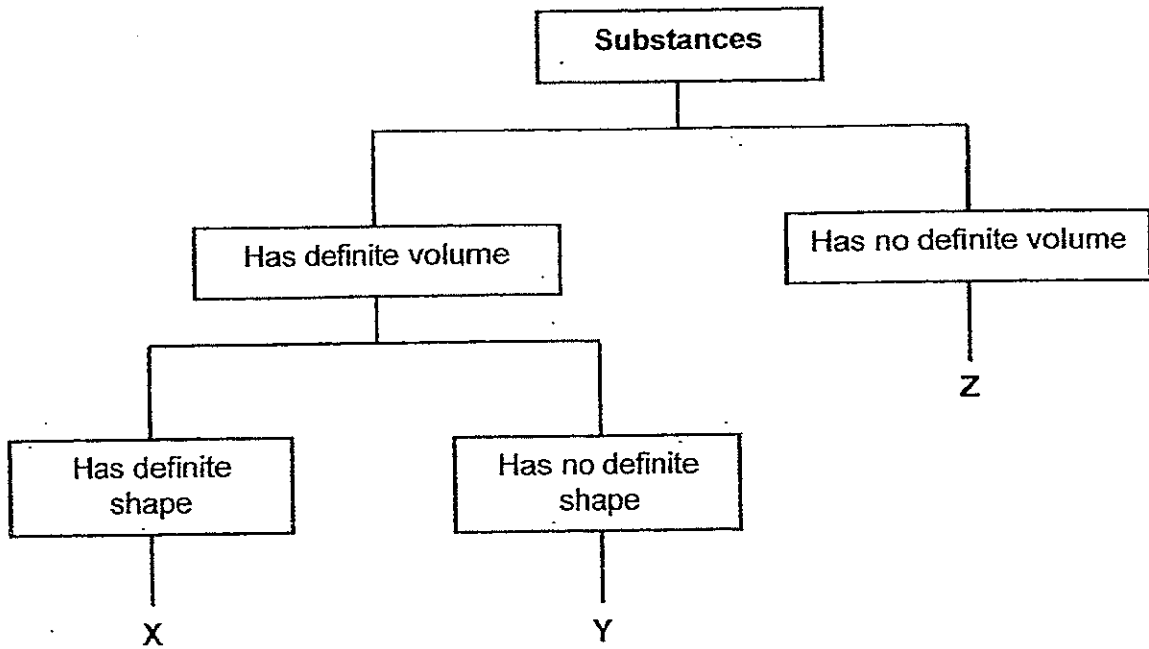

Using the information in the chart above, answer the following questions.

a) How are substances X and Y different? [1m]

b) How are substances X and Y similar? [1m]

c) Which substance, X, Y or Z, can be compressed? [1m]

d) Fill in the blanks below using the correct words from the following list. [1m]

Air	Pebble	Oil
-----	--------	-----

i) Substance Y - _____

ii) Substance Z - _____



13. Jane wanted to find out how to measure the volume of a marble.

Her teacher gave the following items for her to use.

- 500ml of water
- measuring cylinder
- marble

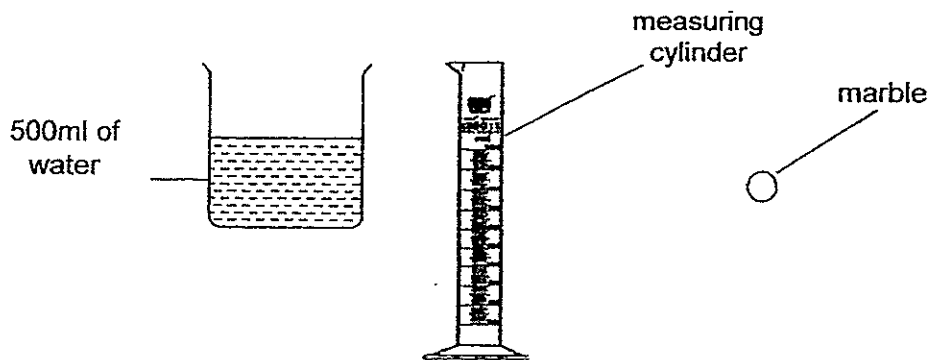

Using the given items, Jane took the following steps.

However, they are not in the right order.

Write 2, 3 and 4 in the boxes below to show the correct sequence of the steps.

[2m]

Calculate the difference in the water level.	
Pour 500 ml of water into the measuring cylinder.	
Take the reading of both the water and marble.	
Put the marble into the measuring cylinder.	

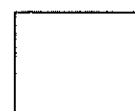

34. Two identical beakers of water, A and B (with temperature of water at 25°C) were heated with gas burners.

The water in the beakers is heated to 100°C and left to **cool down** to room temperature.

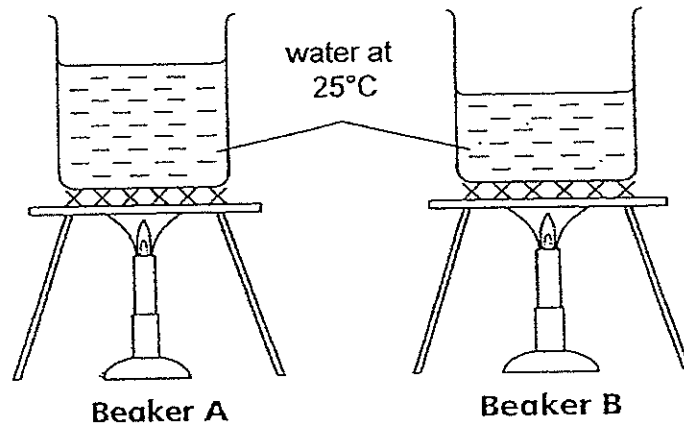

The temperatures of the water in both beakers are shown in the graph below.

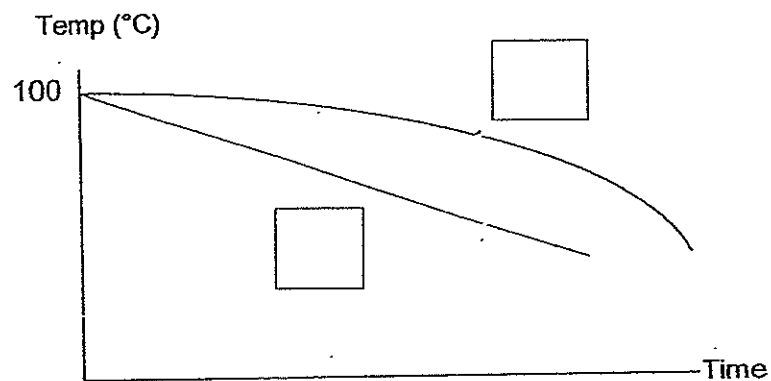

- a) On the line graph above, fill the boxes with A and B to show the changes in the temperature of the water in the two beakers correctly. [1m]
- b) Which beaker of water, A or B, will take a longer time to reach the room temperature? [1m]
-
- c) Give a reason for your answer in (b). [1m]
-
-



35. Karen prepared some fried noodles and placed them on a plate. Then she stirred the hot noodles with a pair of chopsticks as shown below.

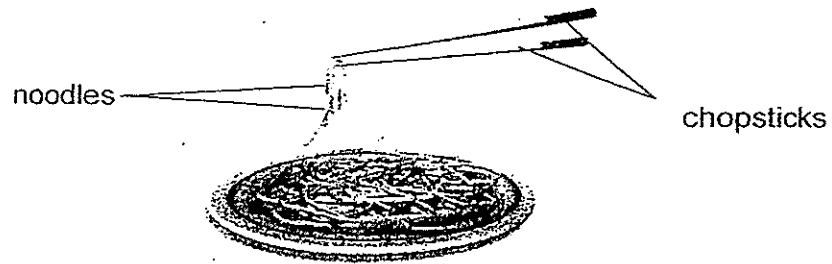

- a) Based on the diagram above, fill in the table below by putting a tick (✓) in the correct box. [1m]

	Gains heat	Loses heat
Chopsticks		
Surrounding air		

- b) Karen left her plate of noodles on the table. An hour later, she observed that the noodles had turned cold. [1m]

Give a reason for her observation.



36. Andy set up an experiment as shown below.

He gently heated flask A with a flame. After some time, substance X is produced.

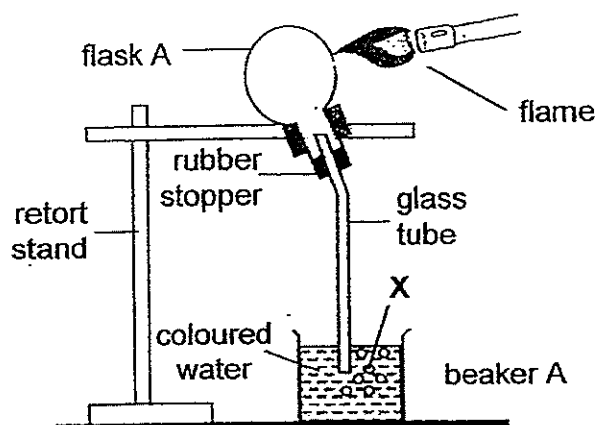

a) What is substance X?

[1m]

Andy then removed the flame and covered the flask with a cold wet towel.

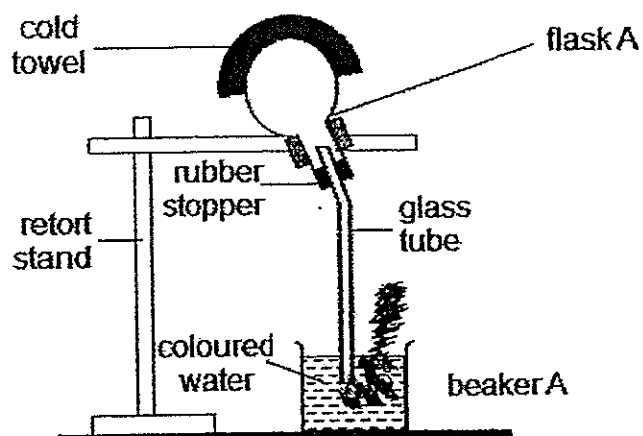

b) What would he observe about the coloured water in beaker A?

[1m]

c) Explain your answer in (b).



37. Jenny wanted to find out which container is the best conductor of heat. She conducted an experiment using three similar containers, made of different materials.

She filled each of them with water at 5°C. She put the three setups in her room and measured the change in temperature of the water every five minutes.

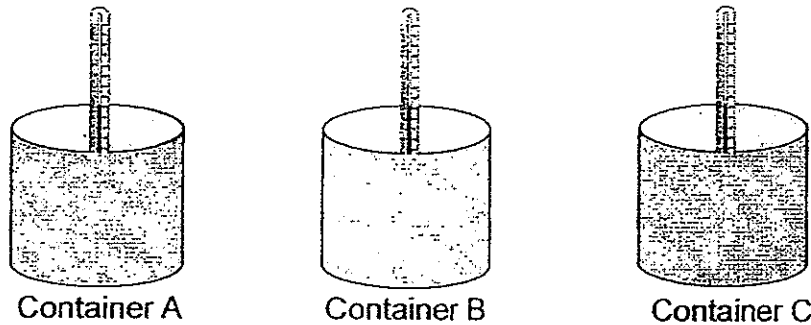

She then recorded the results in the table below.

Time (min)	Temperature of water (°C)		
	Container A	Container B	Container C
0	5	5	5
5	7	9	6
10	10	14	7
15	12	18	8
20	15	23	10
25	18	27	11

- i) Based on the results above, which container is the **best** conductor of heat? [1m]

Which container is suitable to keep food warm for the longest period of time? [2m]

Use the information from the table above to explain your answer.

Explain why the thickness of the containers must be kept the same. [1m]

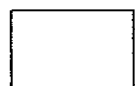

38. Study the diagram below and match the function to its correct system.

[3m]

<u>Function</u>	<u>System</u>
Helps the body get the oxygen it needs. •	• Circulatory System
Pumps blood containing nutrients and oxygen to other parts of the body. •	• Respiratory System
Provides support and protection to the body. •	• Skeletal System

39. The table below shows three organs, **K**, **L** and **M**, in the digestive system and their functions.

Organs	Digests food	Digested food absorbed into the bloodstream
K	✓	
L	✓	✓
M	✓	

a) From the table above, identify organ **L**.

[1m]

Organ L: _____

b) What substance in the three organs digests food?

[1m]



40. The following processes, A, B, C and D, take place in various parts of the digestive system during digestion.

- A: Saliva is produced to break down food into smaller pieces.
- B: Water is absorbed from undigested food.
- C: Partially digested food is pushed down the muscular tube.
- D: Food is digested and absorbed into the blood stream.

a) Write the letters, A, B, C and D, in the correct boxes below according to the order that each process takes place during digestion. [2m]

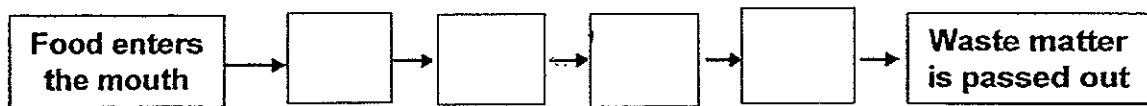

b) Name another part of the digestive system that helps in breaking down food into smaller pieces during Process A. [1m]

41. Observe the two types of organisms below.



Organism S

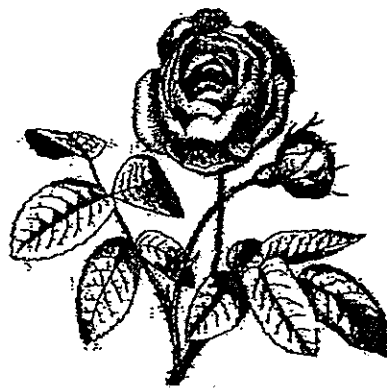

Organism T

i) Which **group** of living things both organisms S and T belong to? [1m]

ii) State the **difference** in how Organisms S and T reproduce. [1m]



42. Mary prepared the set up below.

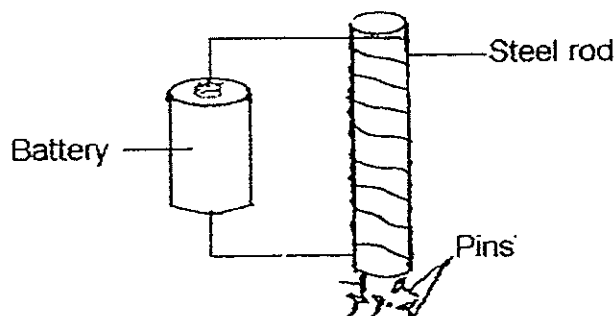

a) What can be observed when Mary put some **steel pins** at the bottom of the steel rod? [1m]

b) State two ways Mary can increase the strength of the electromagnet above. [2m]

1: _____

2: _____

43. Darren held a magnet on one side of a piece of paper and a copper disc on the other side of the paper shown in the diagram below.

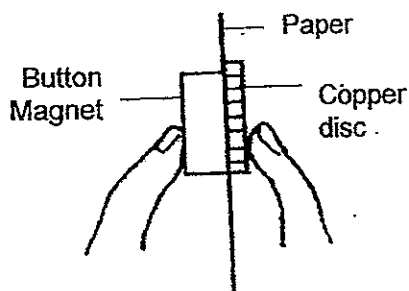

However, he observed that when he moved his finger away from the copper disc, it fell off.

a) Explain why the copper disc fell off. [1m]

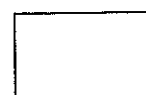

Q43 continued

b) What is Darren likely to observe if the copper disc is replaced by a steel disc? [1m]

c) Explain your answer in (b). [1m]

44. The diagrams below show two groups of plant parts.

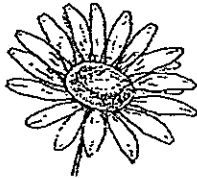
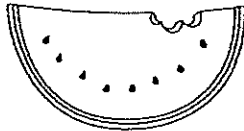
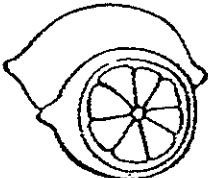
Group A		Group B	
			
Hibiscus	Daisy	Watermelon	Lemon

Write suitable headings for Group A and Group B. [2m]

Group A: _____

Group B: _____

End of Booklet B

etters: Mdm Doris Heng
Mdm Fathlon Tawfik
Mr Yuan Kee King



Henry Park Primary School P4 Semestral Examination 1 Science 2014

Booklet A

1	2	3	4	5	6	7	8	9	10	11	12	13	14	15
4	2	3	2	2	2	3	1	4	3	1	3	2	3	4
16	17	18	19	20	21	22	23	24	25	26	27	28	29	30
4	2	1	4	3	3	1	3	1	1	4	2	3	1	2

Booklet B

- 31 a Cup B
 b More water would enter cup B as with the holes at its base, the air can escape to allow more water to enter the cup to displace the air when immersed into the water, while in cup A without holes at the base, there will be no air escaping hence lesser volume of water can enter the cup.

- 32 a Substance X has definite shape while substance has no definite shape.
 b Both substances X and Y has definite volume.
 c Substance Z.
 d (i) oil (ii) air

33

4
1
3
2

- 34 
 a
 b Beaker A
 c It has more water so there is more heat to lose to reach the room temperature.

35

a

Gains heat	Loses heat
√	
√	

- b The noodles lost heat to the surrounding air.

36

- a Substance X are air bubbles.
 b It will decrease in volume.
 c Air in flask A cooled and contracted to occupy a smaller volume hence drawing the coloured water into the glass tube.

37

- a Container B.
 b Container C. It has the lowest temperature after 25 minutes.
 c To ensure a fair and accurate test.

38



39

- a Small intestine
 b Digestive juice

40

- a Food enters the mouth → A → C → P → B → Waste matter is passed out
 b The teeth chew the food into smaller pieces.

- 41 a Plants.
b Plant S (non-flowering) reproduces by spores while T (flowering plant) reproduces by seeds.
- 42 a The pins will be attracted to the steel rod.
b 1: Increase the number of coils
2: Increase the number of batteries
- 43 a The copper disc is not a magnetic material.
b The steel disc will be attracted to the button magnet.
c It is a magnetic material.
- 44 Group A: Flowers
Group B: Fruits