



AI TONG SCHOOL
2014
END-OF-YEAR EXAMINATION
PRIMARY 4

SCIENCE

DURATION : 1hr 45 minutes

DATE: 27th October 2014

INSTRUCTIONS

Do not open the booklet until you are told to do so.

Follow all instructions.

Answer all questions.

Name : _____ ()

Class : Primary _____

Parent's Signature : _____

Date : _____

Section A	
Section B	
Total	100

Section A: 60 marks

For each question from 1 to 30, four options are given. One of them is the correct answer. Make your choice and shade the oval (1, 2, 3 or 4) on the Optical Answer

1. Study the diagram below.

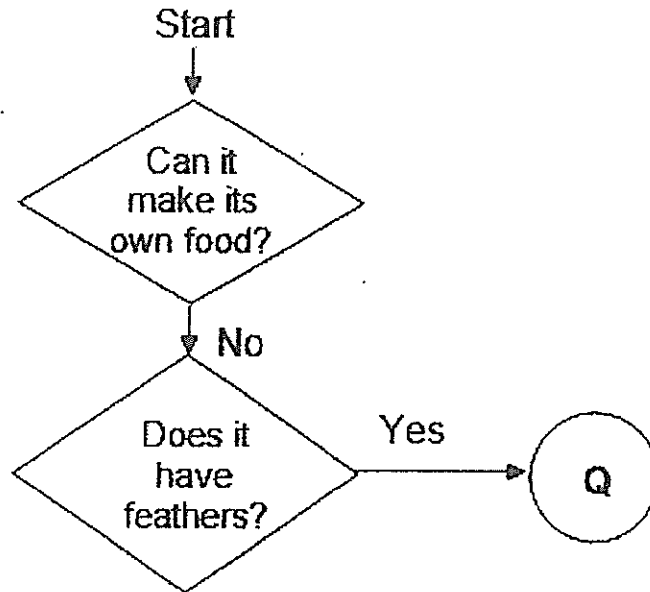

What could Q be?

- (1) bird
- (2) insect
- (3) mammal
- (4) plant

2. The diagram below shows the growth of a young plant with two missing stages P and Q.

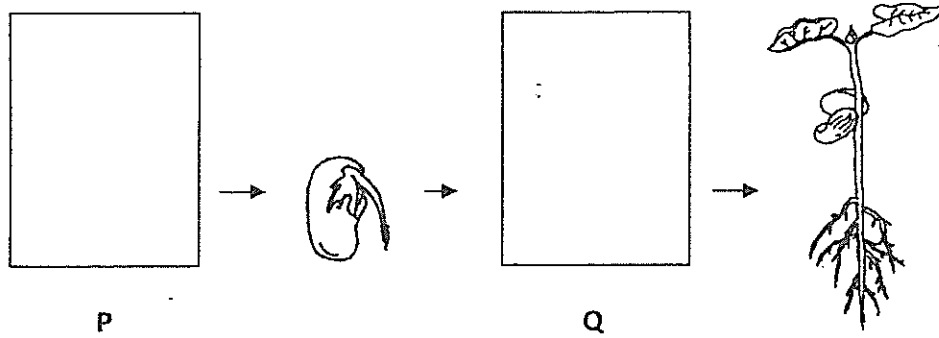

Which one of the following shows the correct stages for P and Q?

	P	Q
(1)		
(2)		
(3)		
(4)		

3. Which one of the following shows the correct order when food moves through some parts of the digestive system?

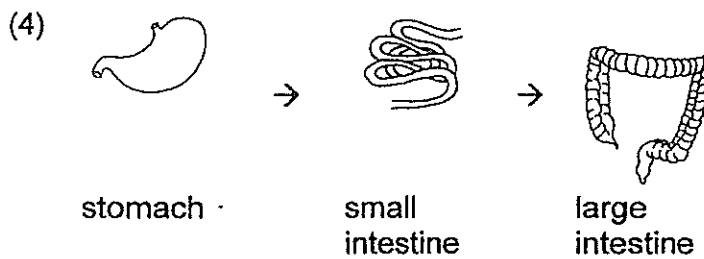
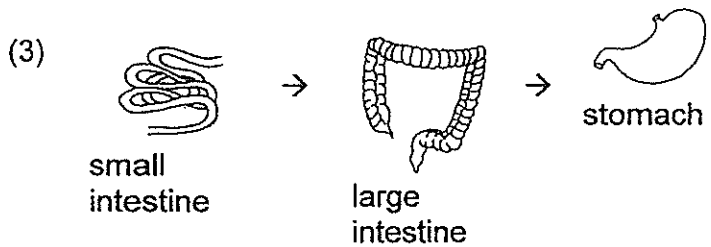
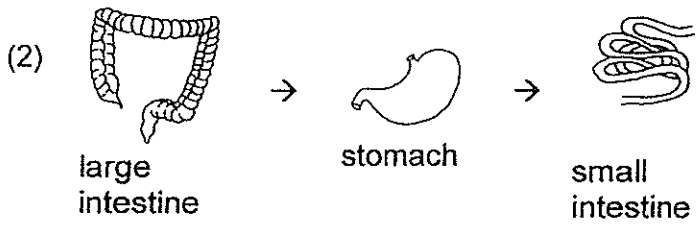
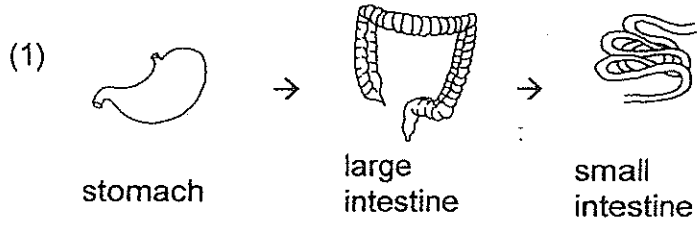

4. Which one of the following is **NOT** a source of heat?

- (1) A candle flame
- (2) A lighted bulb
- (3) A woollen cap
- (4) The Sun

5. Which one of the following objects can be bent easily without breaking?

(1)

A sheet of glass

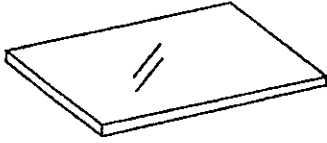

(2)

A plastic spoon



(3)

A towel



(4)

A wooden ruler



6. Which one of the following properties is true for both air and a pencil?

- (1) They can be seen.
- (2) They have fixed shapes.
- (3) They have fixed volumes.
- (4) They take up space.

7. Matter is anything that has mass and occupies space.

Which one of the following is NOT matter?

- (1) Air
- (2) Shadow
- (3) Soil
- (4) Water

8. Look at the picture below.

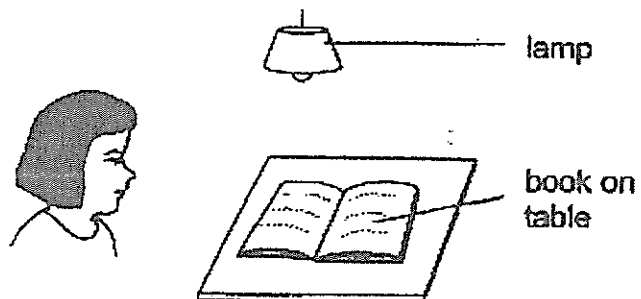

Which of the following explains why Sue can see the book on the table?

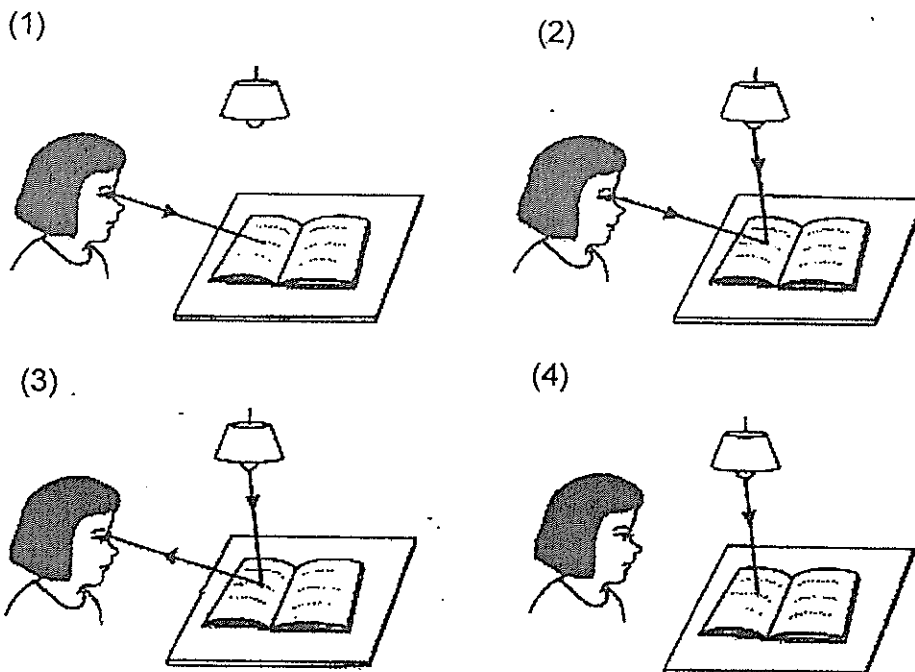
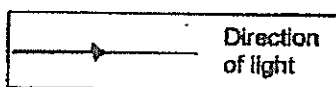

9. In the diagram, what is the volume of liquid Y?

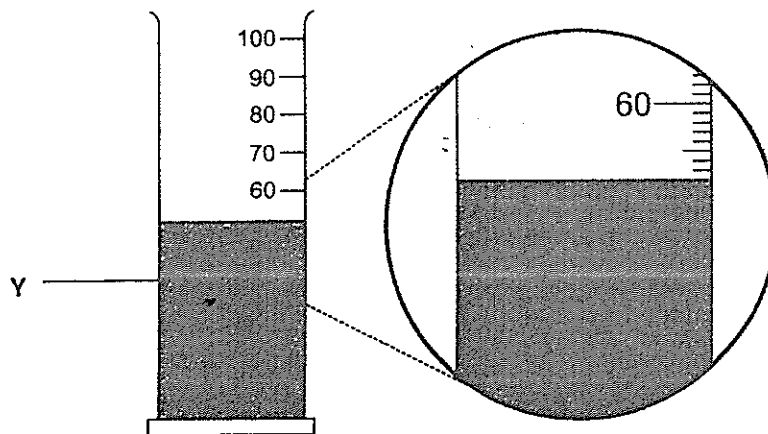

- (1) 50 ml
- (2) 52 ml
- (3) 62 ml
- (4) 68 ml

10. In which one of the following will the two magnets push each other away?

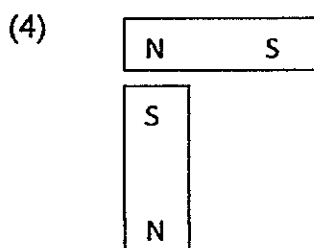
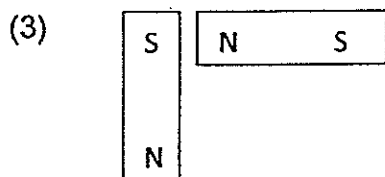
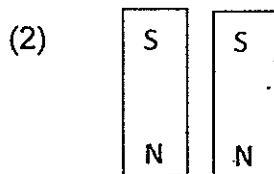
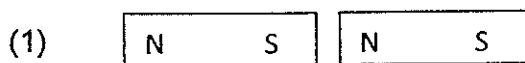

11. Which one of the following is likely to show signs of fungus growth after a few days?

(1)



dry wooden plank

(2)

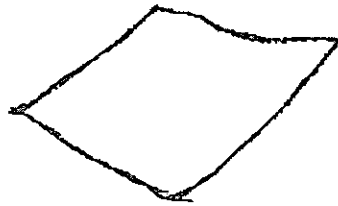

clean, white paper

(3)



damp pieces of wood

(4)

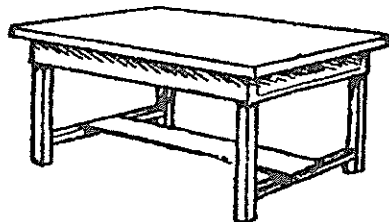

wet, plastic table

12. The diagram below shows a tank set up to keep Organism K. Sufficient amount of food and water is given to Organism K.

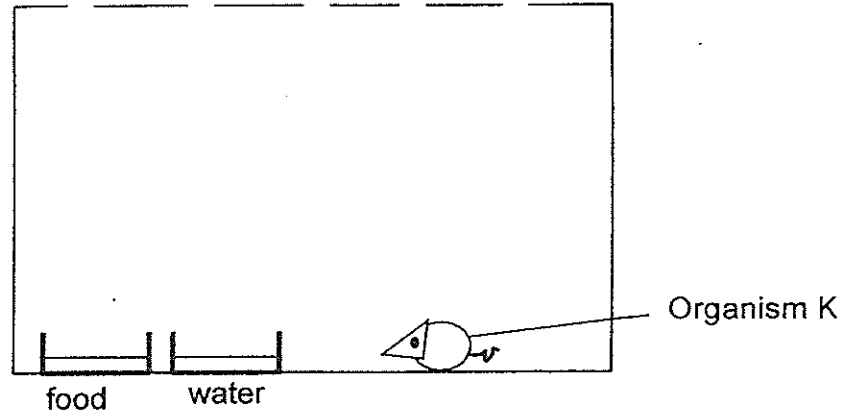

Lena decided to keep 7 Organism K in the tank. After a week she realised that the tank was too crowded with so many organisms living in it.

Which of the following observations would best support Lena's idea?

	Observation 1	Observation 2
(1)	The amount of food and water decreases.	Organisms playing with one another.
(2)	The tank becomes warmer.	Organisms feeding on the food and water.
(3)	Organisms feeding on the food and water.	Some organisms are running around while some are sleeping.
(4)	Organisms fight with one another.	Amount of food and water decreases a lot.

13. The following set-ups were used to carry out an investigation.

Set-up A
Put under light (4°C)

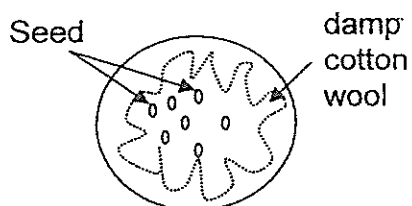

Set-up B
Put in the dark (30°C)

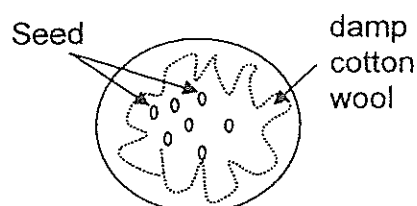

Set-up C
Put under light (30°C)

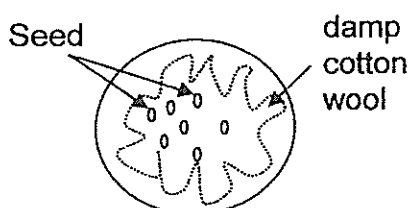

Set-up D
Put in the dark (4°C)

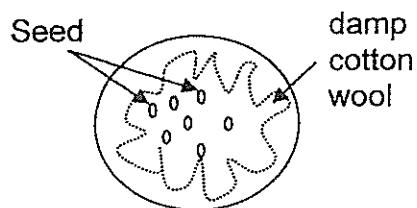

Which of the following aim of experiment is **NOT** correctly matched to the pairs of set-ups?

	Set-ups	Aim of Experiment
(1)	A and D	To find out if seeds can germinate on cotton wool
(2)	B and D	To find out if temperature affects germination
(3)	B and C	To find out if light is needed for germination
(4)	A and C	To find out if seeds can germinate in a cool place

14. The following table gives information about four animals, A, B, C and D based on two characteristics. A tick (✓) shows that the animal has the characteristic.

Animal \ Characteristics	A	B	C	D
Lives in water		✓	✓	
Gives birth to young alive	✓		✓	

Based on the information given in the table above, where should Animal B and Animal D be placed (W, X, Y or Z) in the classification table below?

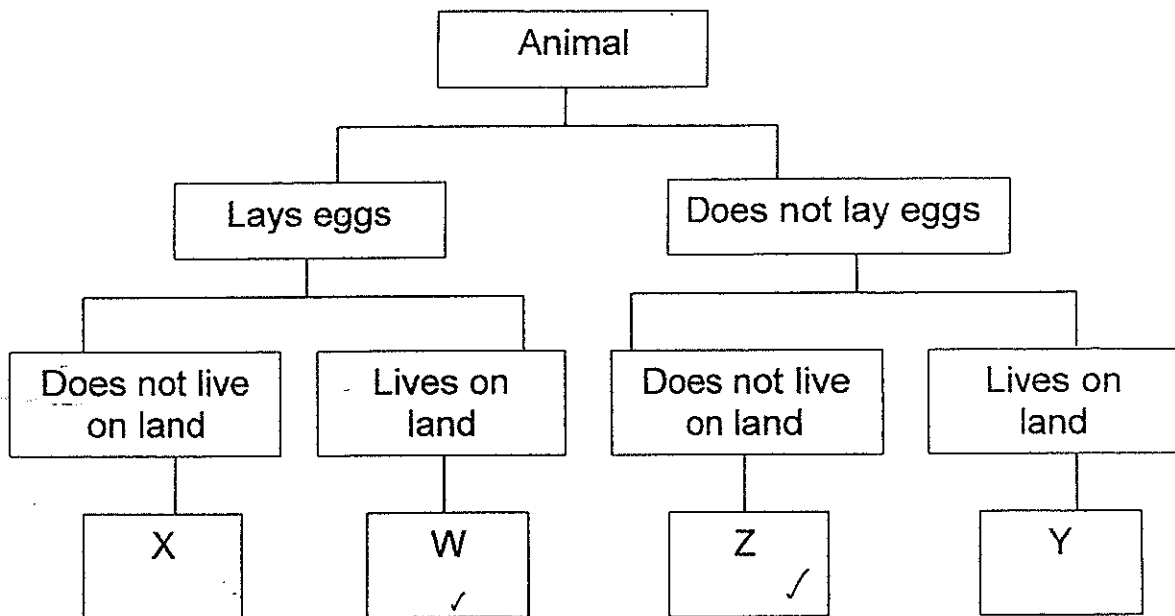

Which of the following correctly matches animals B and D to the animals in the classification table above?

	Animal B	Animal D
(1)	W ✓	Z ✓
(2)	X	W
(3)	Y	W
(4)	Z	X

15. Ken ate a sandwich for lunch. The bar graph below shows the amount of sandwich digested at different parts X, Y and Z of his digestive system.

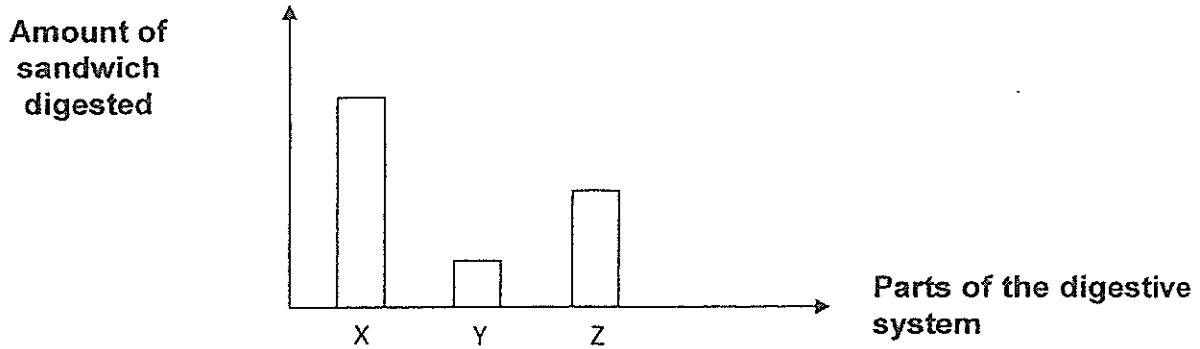

Which of the following shows the correct parts of the digestive system?

	Part X	Part Y
(1)	Stomach	Small intestine
(2)	Small intestine	Mouth
(3)	Mouth	Small intestine
(4)	Small intestine	Stomach

Study the diagram shown below and answer questions 16 and 17.

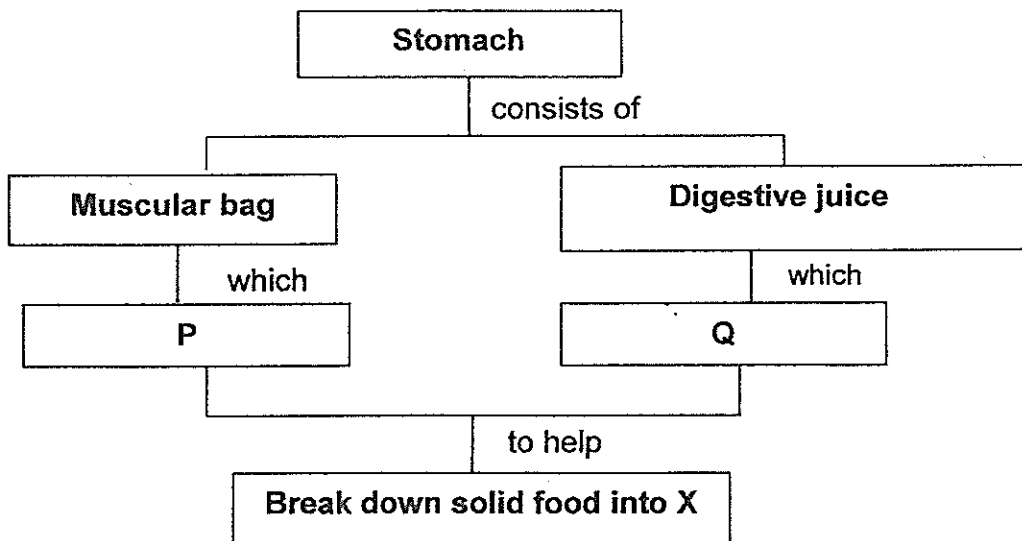

16. In the diagram shown above, X refers to _____

- (1) undigested food
- (2) simpler substances
- (3) smaller pieces of food
- (4) simpler pieces of food

17. Which of the following best describes P and Q?

	P	Q
(1)	Absorbs water	Absorbs nutrients
(2)	Shapes food into small balls	Pushes food down
(3)	Partly digests the food	Churns food with digestive juices
(4)	Churns food with digestive juices	Digests the food

18. Two hooks A and B made from different materials were secured to the ceiling.



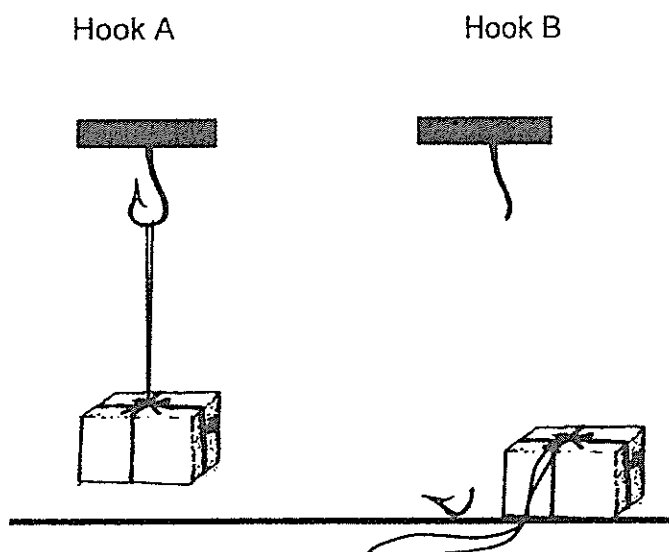

Two boxes of the same mass were hung onto the hooks. The results were shown below.



From this experiment, we can conclude that _____.

- (1) Hook A is lighter than Hook B
- (2) Hook A is stronger than Hook B
- (3) Hook A is more fragile than Hook B
- (4) Hook A is more flexible than Hook B

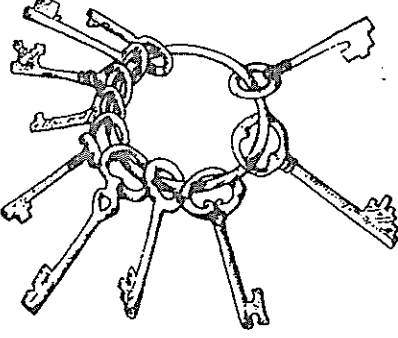
19. Four objects are classified into two groups as shown below.

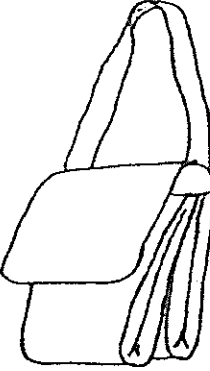
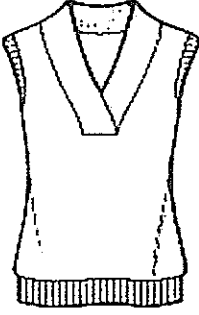
Group A	Group B
 <p data-bbox="432 857 499 891">keys</p>  <p data-bbox="403 1283 544 1317">Glass cup</p>	 <p data-bbox="946 880 1090 913">schoolbag</p>  <p data-bbox="962 1328 1058 1361">blouse</p>

The objects are grouped according to _____.

- (1) how hard they are
- (2) what materials they are made of
- (3) whether they conduct heat easily
- (4) whether they allow light to pass through

20. Keith placed equal drops of wax on the handles of Spoons A and B. The wax hardened and he placed the two spoons into beakers of water at 95°C as shown below.

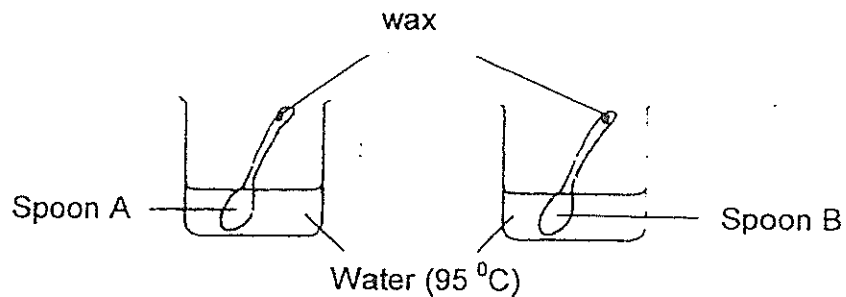

After 10 minutes, he noticed that the wax on Spoon A melted first.

Which one of the following is a possible reason why the wax on Spoon A melted first?

- (1) The temperature of the water was higher.
 - (2) Spoon A expanded when heated by the hot water.
 - (3) Heat travelled quickly from Spoon A to the hot water.
 - (4) Spoon A conducted heat more quickly than Spoon B.
21. The diagram below shows hot water in a covered plastic container.

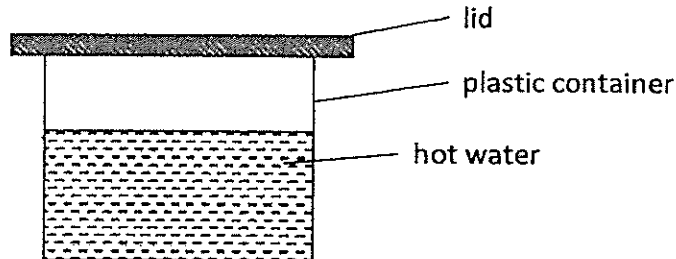

Which of the following correctly describes the temperature changes of the air in the plastic container and the hot water after 10 minutes?

	Temperature of	
	Air in plastic container	Hot water
(1)	Decrease	Increase
(2)	Decrease	No change
(3)	Increase	Decrease ✓
(4)	Increase	No change

22. The diagram below shows some water in set-ups A, B, C and D.

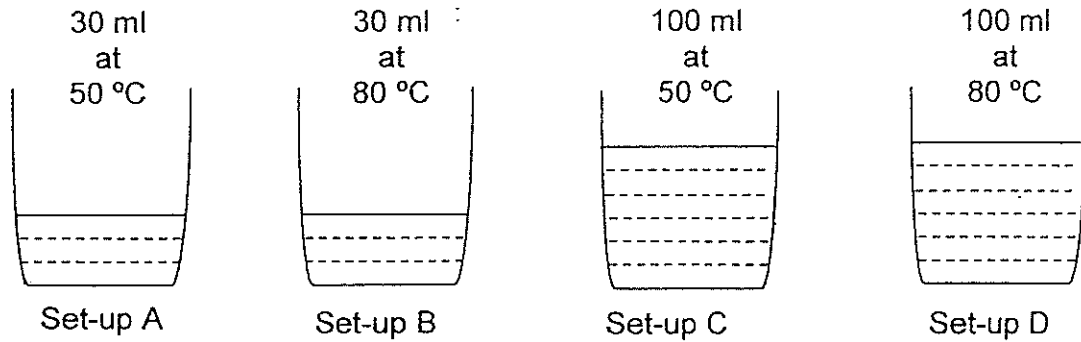

Ali compared 2 set-ups.

Which of the following shows an **incorrect** comparison?

	Set-ups	Comparison
(1)	A and B	The water in set-up B has more heat energy.
(2)	A and C	The water in set-ups A and C have equal amount of heat energy.
(3)	C and D	The water in set-up C has less heat energy.
(4)	B and D	The water in set-up D has more heat energy.

23. Shawn heated 4 materials, P, Q, R and S for 10 minutes. The graph below shows the increase in their temperatures after 10 minutes.

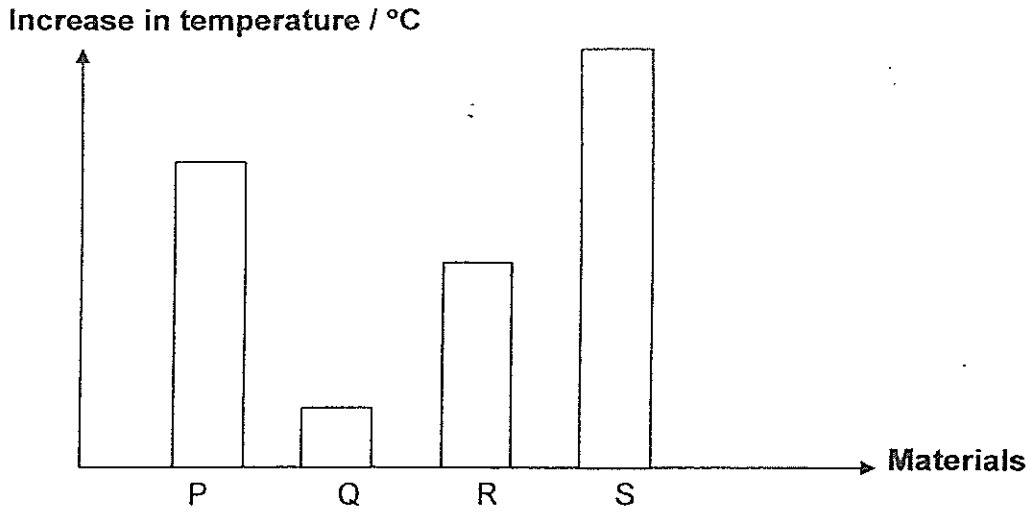

Based on the graph above, which material, P, Q, R or S, is the most suitable material to be made into part X and Y of the iron?

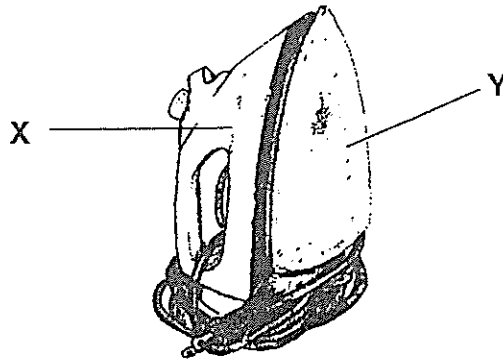

	Part X	Part Y
(1)	P	Q
(2)	Q ✓	R
(3)	S	P
(4)	Q ✓	S ✓

24. Harry carried out an investigation on a gas.

He placed some of the gas in a flask and sealed it. He drew the diagram below to represent the gas in the flask.

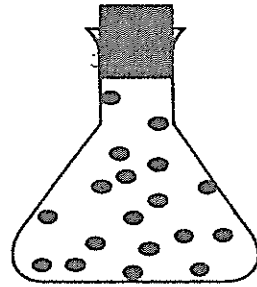

Harry then removed some of the gas from the flask.

Which of the following best represents the gas remaining in the flask?

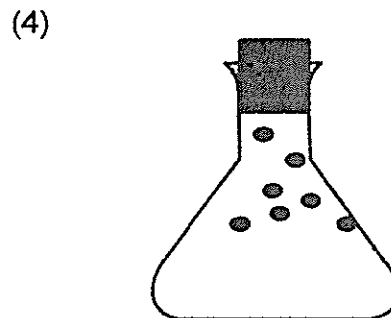
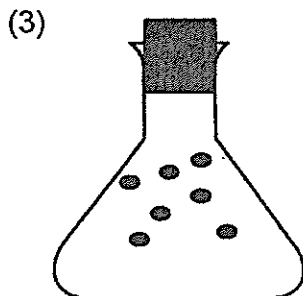
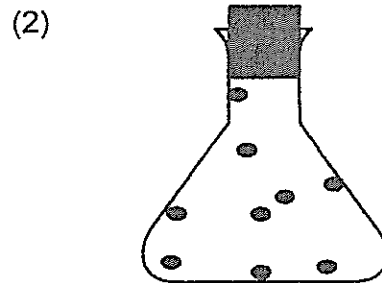
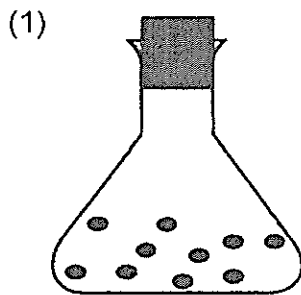

25. Which of the following statements about heat and temperature is true?

	Heat	Temperature
(1)	Heat is the measure of degree of hotness or coldness.	Temperature is a form of energy.
(2)	Heat can be measured using a thermometer.	Accurate temperature can be measured using sense of touch.
(3)	Heat is a form of energy.	Hot objects have higher temperature.
(4)	Heat is not a matter.	Temperature is a matter.

26. The table below shows three problems faced by three different people.

Description	Object used to solve the problem
Mr Tan wants to make doors for the changing rooms in his shop.	X
Baker Wong wants to display his cakes for sale. He wants his customers to be able to see his cakes clearly.	Y
Jane wants to block out the glaring sun while she is driving.	Z

What is the degree of transparency to light of objects X, Y and Z?

	X	Y	Z
(1)	Light cannot pass through the material	Only some light can pass through the material	Most light can pass through the material
(2)	Light cannot pass through the material	Most light can pass through the material	Only some light can pass through the material
(3)	Only some light can pass through the material	Most light can pass through the material	Light cannot pass through the material
(4)	Most light can pass through the material	Only some light can pass through the material.	Light cannot pass through the material

27. Justin measured the length of a shadow formed by a tree at hourly intervals in his school field on a sunny day.

Which one of the following graphs would best represents the results that Justin had obtained?

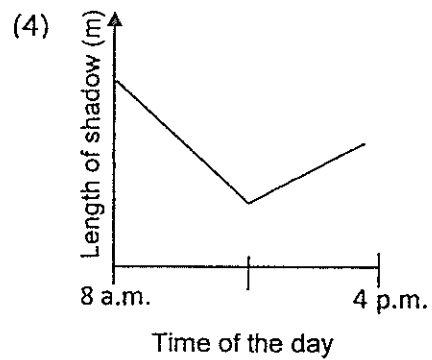
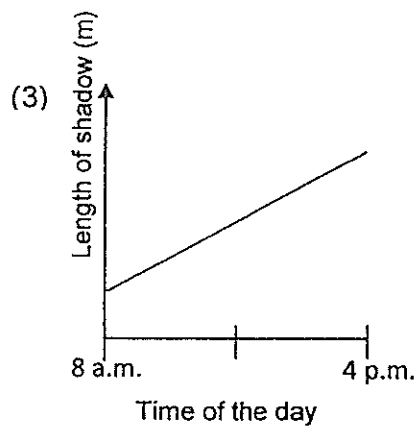
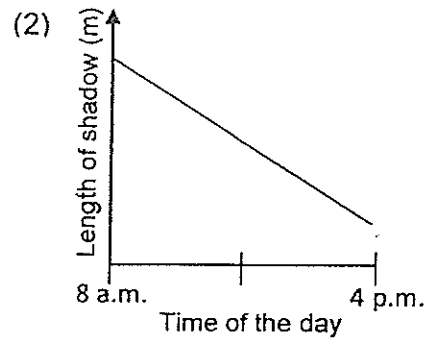
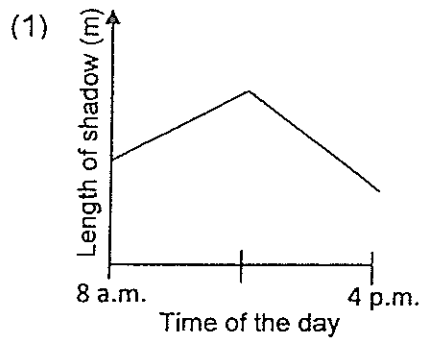

28. Minhui carried out an experiment to find out the strength of magnets labelled A, B, C and D, as shown in the diagram below.

She took each of the magnets and placed them 15 cm away from a pile of paper clips.

The table below shows the number of paper clips attracted by magnets A, B, C and D.

Magnet	Number of paper clips attracted
A	13
B	13
C	17
D	14

Which of the following statement(s) is/are most likely to be correct?

- A Magnet C is the strongest magnet.
- B Magnet D is the weakest magnet.
- C Magnet A is as strong as magnet B.
- D Magnet B is stronger than magnet D.

- (1) A only
- (2) B and D only
- (3) A and C only
- (4) B, C and D only

29. Regan used the set-up below to find out if the number of batteries used affects the strength of the electromagnet.

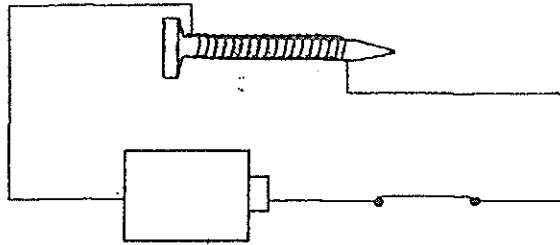

Average number of pins attracted

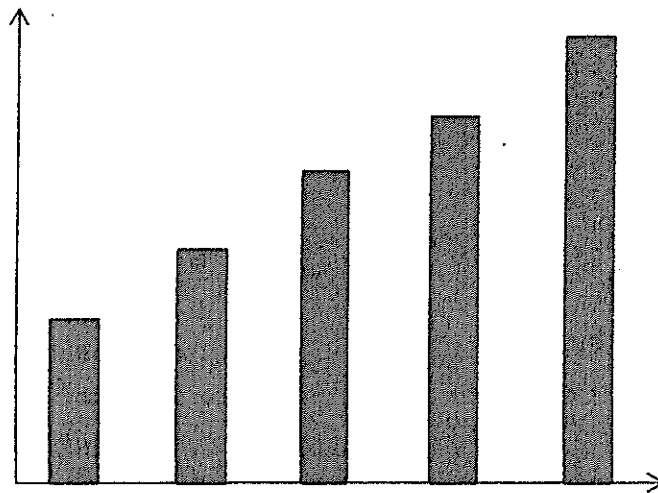

Number of batteries used

What can Regan conclude from the results of his experiment?

- (1) The electromagnet is a strong magnet.
- (2) The type of batteries used will affect the strength of the electromagnet.
- (3) The pins become magnetized when they were attracted to the electromagnet.
- (4) The number of pins attracted increases with the number of batteries used.

30. Four magnets W, X, Y and Z were hung at the same height. The magnets attracted some pins as shown in the diagram below.

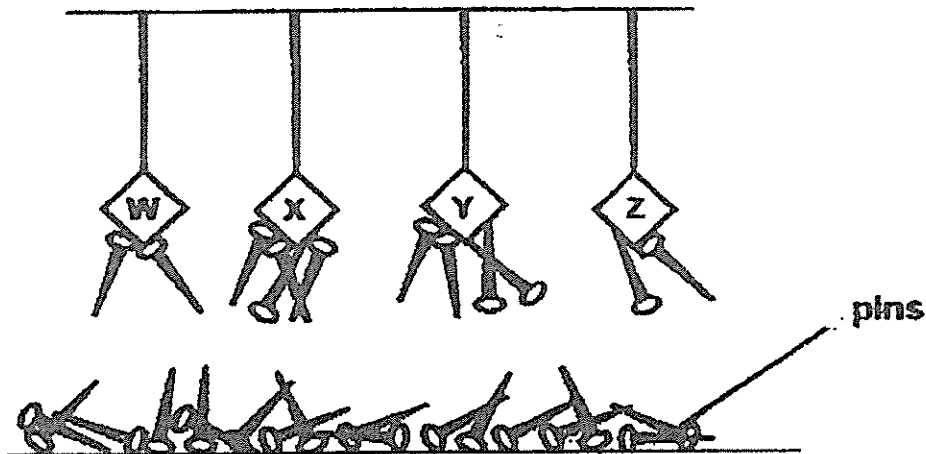

Which of the following would be possible observations if magnet W was replaced with magnet A that can attract 8 pins when hung from the same height as the rest?

	Observation 1	Observation 2
(1)	Magnet X would swing away from Magnet A	Magnet A would attract the least pins
(2)	Magnet X swing towards to Magnet A	Magnet A would attract the most pins
(3)	Magnet X and Y would be attracted to each other	Magnet Z would be attracted to Magnet Y
(4)	All the pins would be attracted to only Magnet A	Magnets Z would attract the least pins

Name: _____ () _____ /40

Class: 4 _____

Section B: 40 marks

Read the questions carefully and write down your answers in the spaces provided.

31.

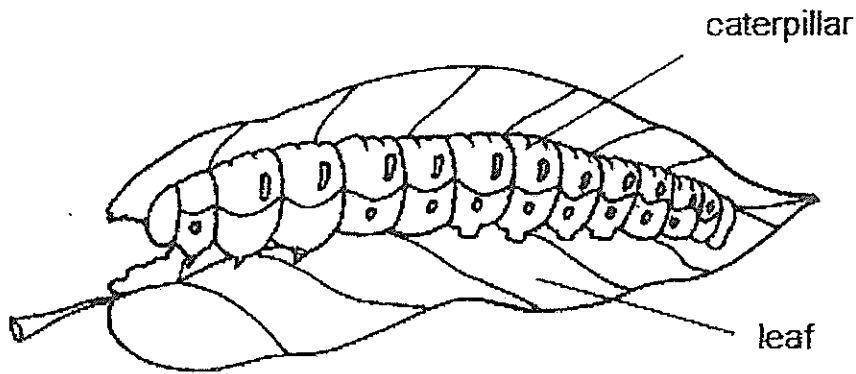

a) The caterpillar needs ~~food, water and~~ _____ ~~to stay alive.~~ [1]

b) The caterpillar ~~eats leaves and becomes longer~~ after some time. This shows that it can _____ [1]

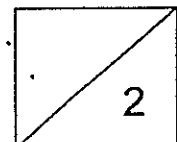

32. The diagram below shows the stages in the life cycle of a butterfly.

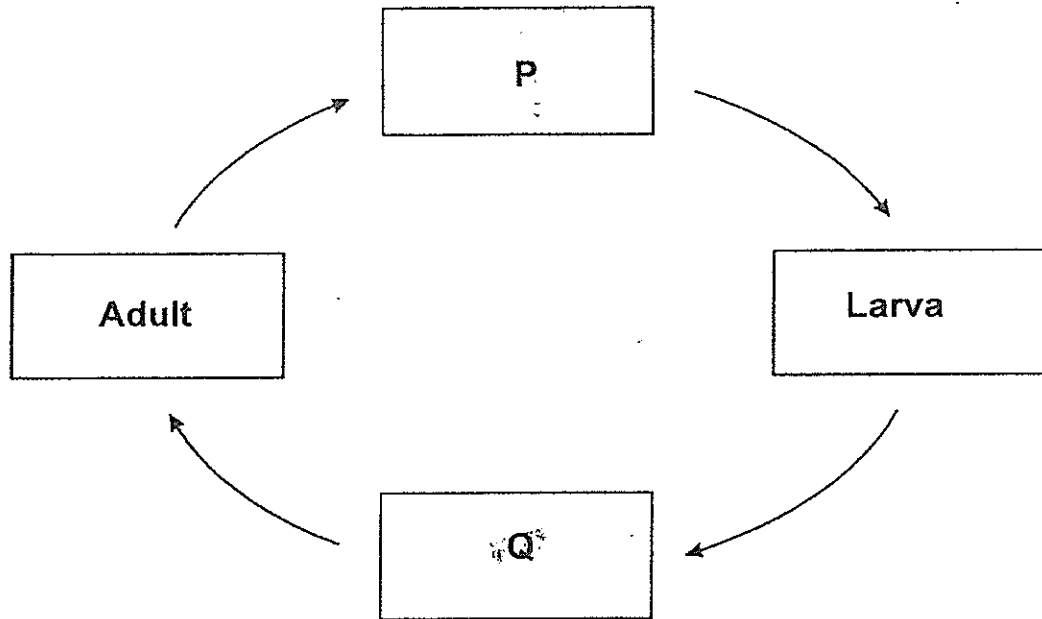

Choose the correct words from the box to answer the question below.

caterpillar	egg	pupa	seed
-------------	-----	------	------

Name the two stages P and Q.

[2]

P: _____

Q: _____

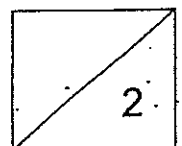

33. The diagram below shows a car.

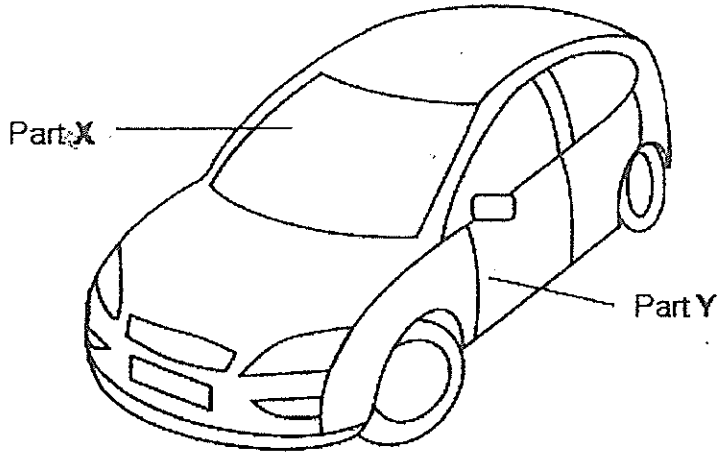

a) Part X is made of glass because it allows _____ [1]
to pass through so that the driver can see the road.

b) Part Y is made of _____ because ~~it~~ it has to be strong. [1]

34.

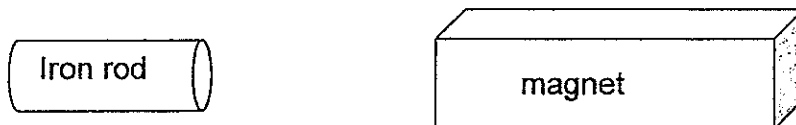

Susan places a magnet near an iron rod. The iron rod moves towards the magnet.

a) The magnet exerts a _____ on the iron rod. [1]

Choose the correct word from the box to answer the question below.

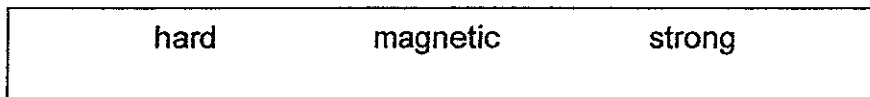

Susan's observation shows that iron is a _____ material. [1]

35. Leena shines a torch on a ball and a shadow is formed on a smooth wall.

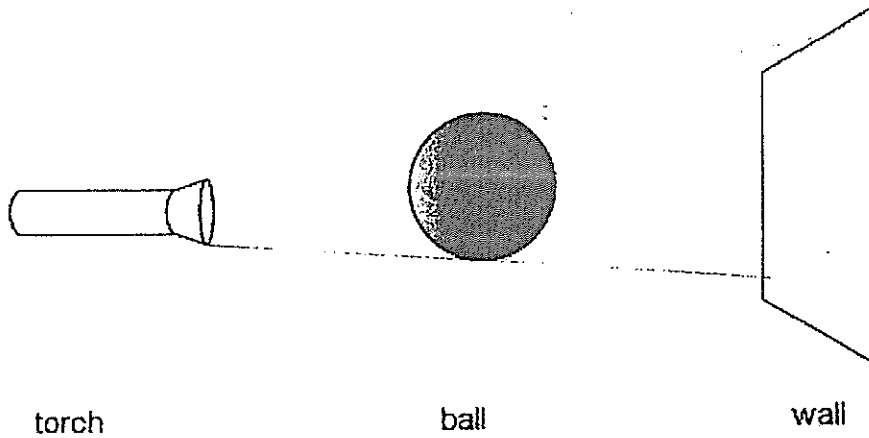

a) A shadow is formed when light is _____ by an object. [1]

b) Draw the shadow of the ball that is formed on the wall. [1]

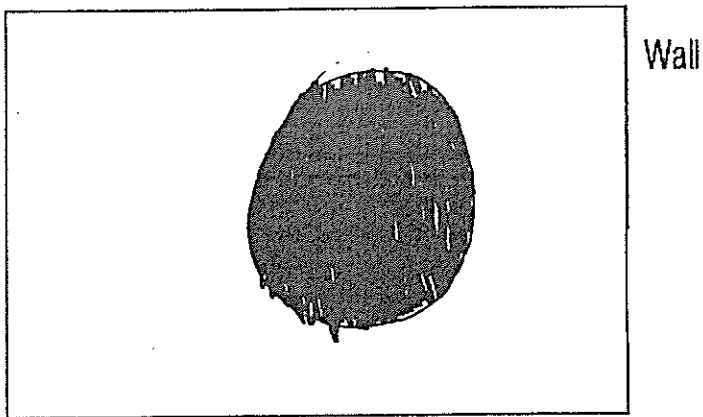

36. Two boys found Organisms P and Q in the garden.

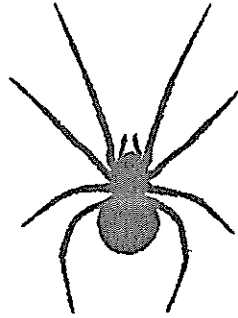

Organism P

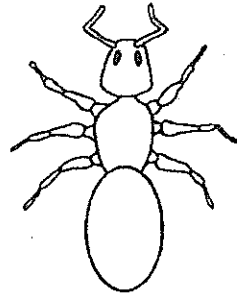

Organism Q

By examining the physical differences of the two organisms, the boys concluded that Organism Q is an insect but not P.

Compare Organisms P and Q and write down the two physical differences that the boys had observed which made them arrive at that conclusion. [2]

Difference 1: _____

Difference 2: _____

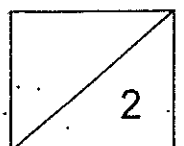

37. The diagram below shows a tree with a thick canopy. This means that the tree has many leaves and branches and forms a thick crown on the tree.

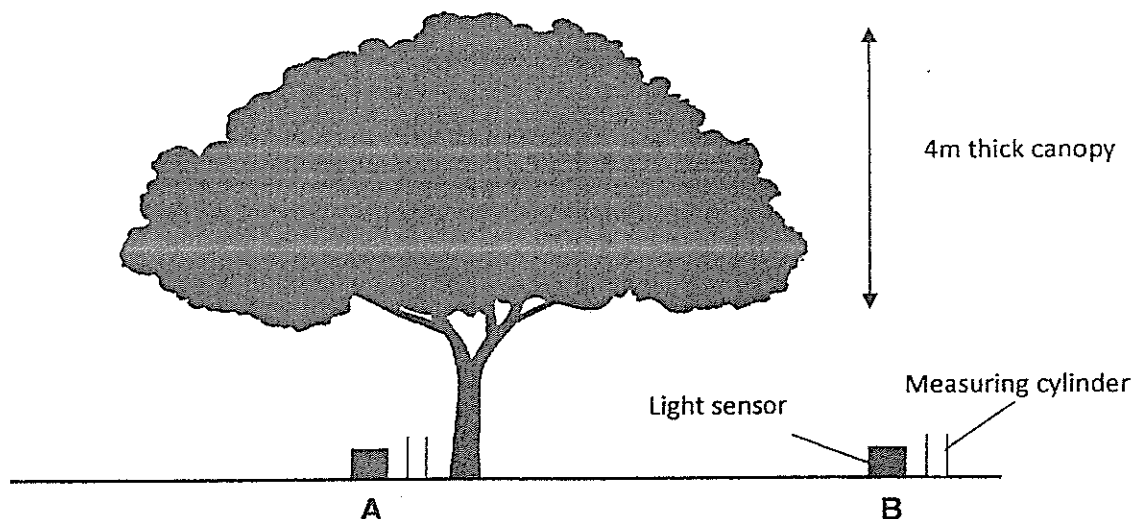

Kate placed a light sensor and a measuring cylinder at positions A and B respectively.

The table below shows the average amount of light detected and the average amount of rainfall collected at Positions A and B in a day.

Position	Average amount of light detected / units	Average amount of rainfall collected / ml
A	2	10
B	85	300

a) Why was there less light detected at Position A? [1]

Kate wants to grow a potted plant as shown below.



b) Which position, A or B, would be a more suitable place to grow the potted plant? Explain your choice. [2]

38. Tom prepared three similar Containers A, B and C that looked like the one shown below.

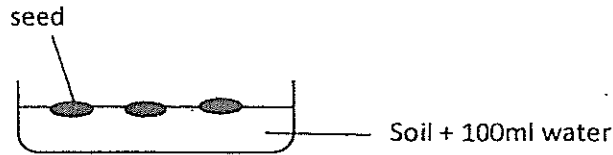

Same amount of water was poured into all the containers. They were then left under different conditions for 2 days and observed if the seeds germinated.

Table 1 below shows the different conditions that Containers A, B and C were placed in.

Table 1		Container A	Container B	Container C
Conditions	Temperature of the surrounding / °C	20	50	30
	Was there light?	Yes	Yes	Yes

Table 2 shows the observations recorded 2 days later.

Table 2		Container A	Container B	Container C
Observations	Dampness of soil after 2 days	Very Damp	Dry	Damp
	Did the seeds germinated after 2 days?	Yes	No	Yes

a) Based on the table above, what is the relationship between the temperature of the surrounding and the dampness of the soil after 2 days? [1]

b) Based on the table above, give 2 reasons why the seeds in container B did not germinate? [2]

39. Tim wanted to find out if the amount of digestive juice affects the rate of digestion of starch. He prepared 4 similar test-tubes containing different amounts of digestive juices and starch.

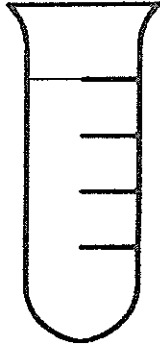
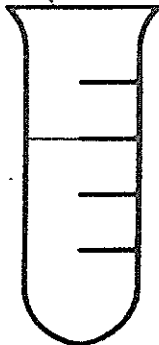
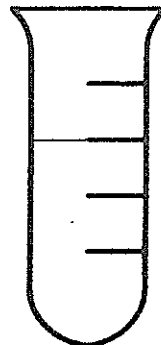
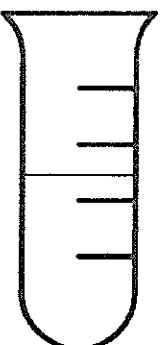
	Test-tube A	Test-tube B	Test-tube C	Test-tube D
				
Amount of starch solution/ ml	20	10	20	20
Amount of digestive juice / ml	20	20	10	5

a) Which 2 test-tubes should Tim use for his experiment? Explain your choice. [2]

b) The more the digestive juice added to the solution, the faster the rate of digestion. In the space below, draw a line graph to show this relationship. [2]

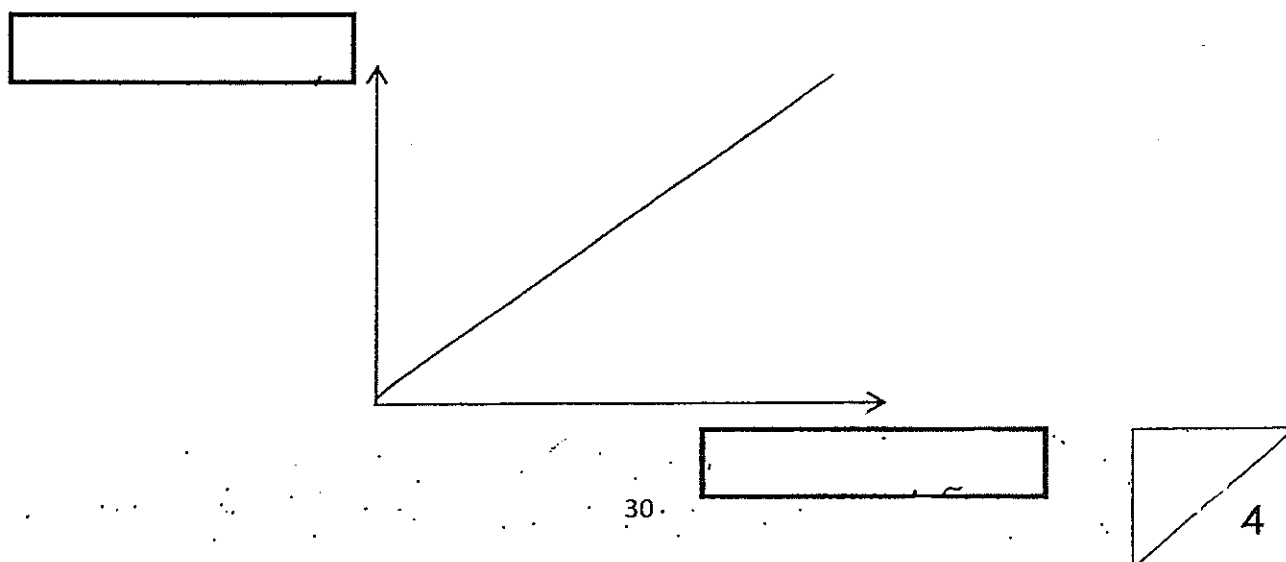

40. Similar cups A and B are used to conduct two experiments.

Experiment 1

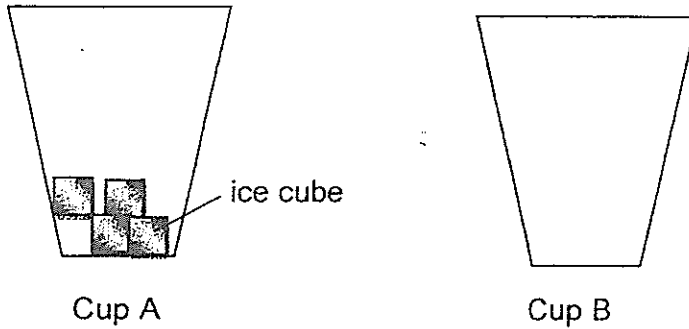

a) Which cup, A or B would need ~~less amount of~~ orange juice to completely fill up the cup? Explain your answer. [2]

Experiment 2

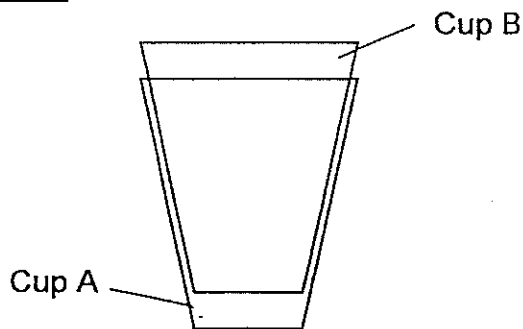

When cup B was placed into cup A, the two cups could not be separated.

b) State ~~2~~ actions that can be done to separate the two cups. [2]

Action 1: _____

Action 2: _____

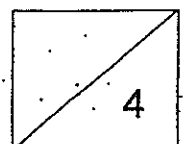

41. Study the set-up below. Samuel wanted to find out what would happen to the ink drop when the empty flask was heated for a few minutes.

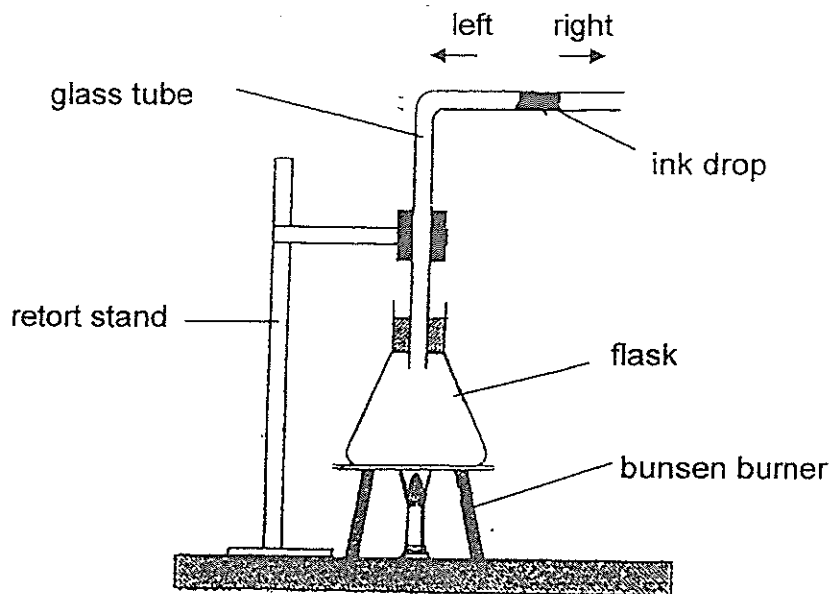

a) When the flask was heated, will the ink drop move right, left or remain in the same position? [1]

b) Explain your answer in (a). [2]

b) How would the result in part (a) be different if she repeated the experiment using 2 bunsen burners? [1]

42. Mary used a horse shoe magnet to carry out an investigation. She labelled Positions A, B and C on the magnet as shown below.

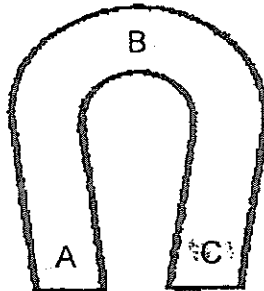

She dipped the magnet into a container of iron nails and counted the number of nails attracted to Positions A, B and C of the magnet. She recorded the results in the table below.

Position	Number of iron nails attracted
A	6
B	1
C	6

- a) What can Mary conclude about the strength of the magnet at Positions A, B and C? [1]

- b) What should Mary do to find out which Position A, B or C is the north-pole of the horse shoe magnet? Mary is given another bar magnet. [2]

43. Jane carried out an experiment as shown below

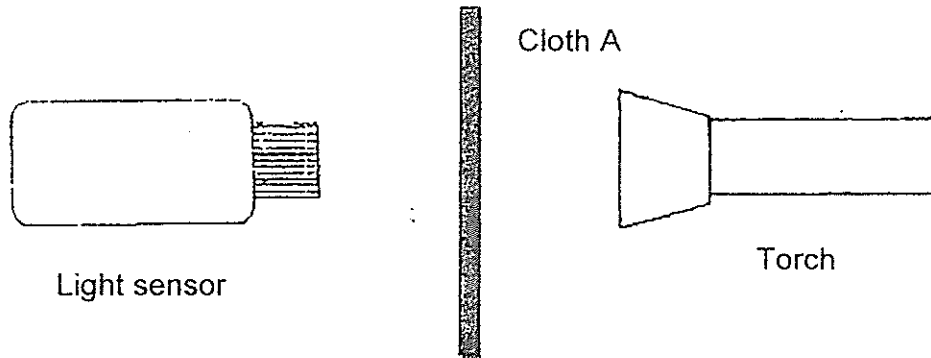

The light sensor records the amount of light passing through Cloth A. She repeated the experiment using Cloths B, C and D

Types of Cloth	Amount of light recorded / Units
A	10
B	50
C	24
D	15

a) What was the aim of the experiment? [1]

b) Arrange the degree of transparency to light of Cloths A, B, C and D. [1]

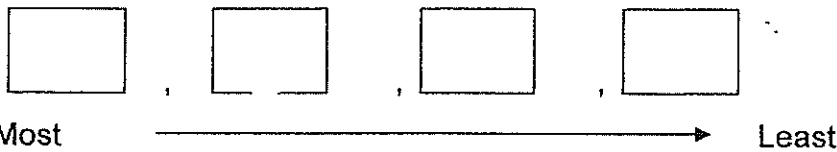

Jane wanted to use the above cloths to make curtains for her bedroom. She prefers to keep her room dark.

c) Which cloth, A, B, C or D should she choose? Explain your answer. [2]

44. Diagram 1 shows a bar magnet that had its poles dipped into a container of iron filings.

Diagram 1

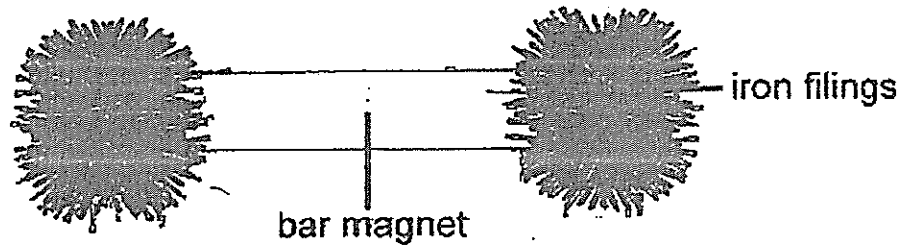
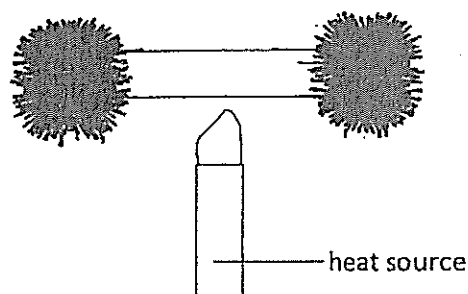

Diagram 2

Diagram 2 shows the same magnet being heated at the centre.



After being heated for some time, 2 observations were made. Give possible explanations for the 2 observations made.

- a) Observation 1: The two ends of the bar magnet became hot. [1]

- b) Observation 2: Some iron filings found at the two ends of the magnet dropped. [2]

END OF PAPER

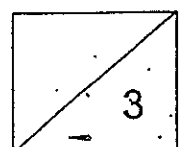

EXAM PAPERS 2014

SCHOOL: AI TONG SCHOOL
SUBJECT: SCIENCE
LEVEL: PRIMARY 4
TERM: SA 2

BOOKLET A

Q1	Q2	Q3	Q4	Q5	Q6	Q7	Q8	Q9	Q10
1	3	4	3	3	4	2	3	2	2
Q11	Q12	Q13	Q14	Q15	Q16	Q17	Q18	Q19	Q20
3	4	1	2	2	2	4	2	1	4
Q21	Q22	Q23	Q24	Q25	Q26	Q27	Q28	Q29	Q30
3	2	4	2	3	2	4	3	4	2

BOOKLET B

- Q31 a) air b) grow
Q32 P: egg. Q: pupa
Q33 a) light b) metal
Q34 a) pulling force, magnetic
Q35 a) blocked b)

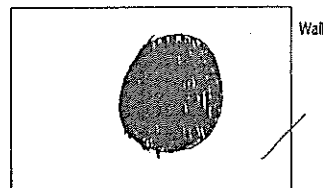

- Q36 Difference 1: Organism Q has 6 legs but P has 8 legs.
Difference 2: Organism Q has three segmented body parts but P has two segmented body parts.
- Q37 a) The canopy blocked some light.
b) Position B. It received more light and water which is needed by the plant to grow plant.
- Q38 a) As the temperature of the surrounding increases, the dampness of the soil decreases.
b) There was not enough water for it to germinate. It was too hot for the seed to germinate.
- Q39 a) A and C
The correct variable was changed and it was the amount of digestive juice.
b)



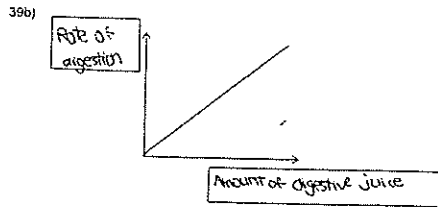

- Q40 a) Cup A. The ice cubes occupies space in the cup leaving less space for the orange juice.
b) Put ice in cup B. Place cup A in hot water.
- Q41 a) The ink drop moved right.
b) The air gained heat from the burner and expand and pushed the ink drop to the right.
c) It will move to the right faster.
- Q42 a) Poles at A and C are stronger than B.
b) Bring the north-pole of the bar magnet close to Position A, B and C. The position that repels the bar magnet is the north pole.
- Q43 a) To find out if the type of cloth affects the amount of light pass through it.
b) B, C, D, A
c) Cloth A. The amount of light detected by the light sensor was the least when cloth A was used. Thus, cloth A blocked the most light from outside the bedroom.
- Q44 a) Heat travelled from the heat source to the cooler ends.
b) Heat causes the magnet to lose some of the magnetism hence it attracts less iron fillings.

