

**CATHOLIC HIGH SCHOOL
SEMESTRAL ASSESSMENT 2
2014
PRIMARY FIVE
SCIENCE**

BOOKLET A

Name: _____ . ()

Class: Primary 5 - _____

Date: 29 October 2014

30 questions

60 marks

Total Time for Booklets A and B: 1 hour 45 minutes

INSTRUCTIONS TO CANDIDATES

Do not turn over this page until you are told to do so.

Follow all instructions carefully.

Answer all questions.

Shade your answers in the Optical Answer Sheet (OAS) provided.

This booklet consists of 22 printed pages, excluding cover page.

Booklet A (30 × 2 marks)

For each question from 1 to 30, four options are given. One of them is the correct answer. Make your choice (1, 2, 3 or 4). Shade your answer on the Optical Answer Sheet. (60 marks)

1 The chart below shows how some living things are classified.

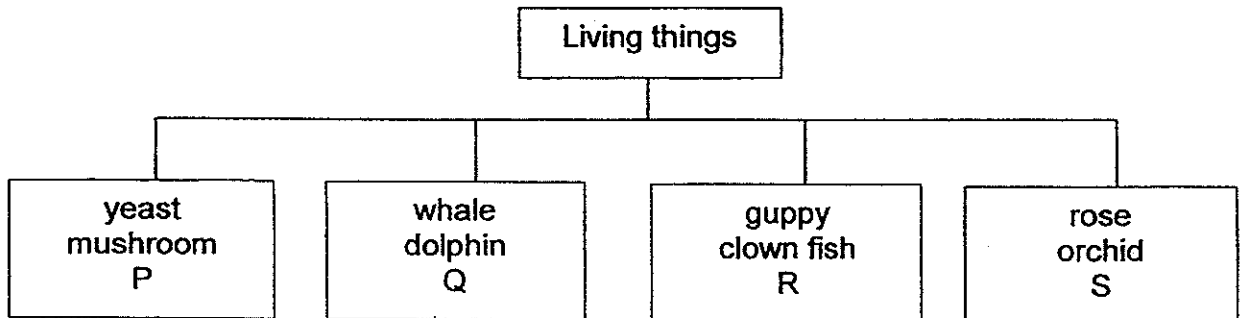

Based on the chart above, which one of the following identifies P, Q, R and S correctly?

	P	Q	R	S
(1)	cactus	shark	elephant	mould
(2)	cactus	elephant	shark	mould
(3)	mould	shark	elephant	cactus
(4)	mould	elephant	shark	cactus

- 2 The diagrams below show the life cycles of a grasshopper and a cockroach.

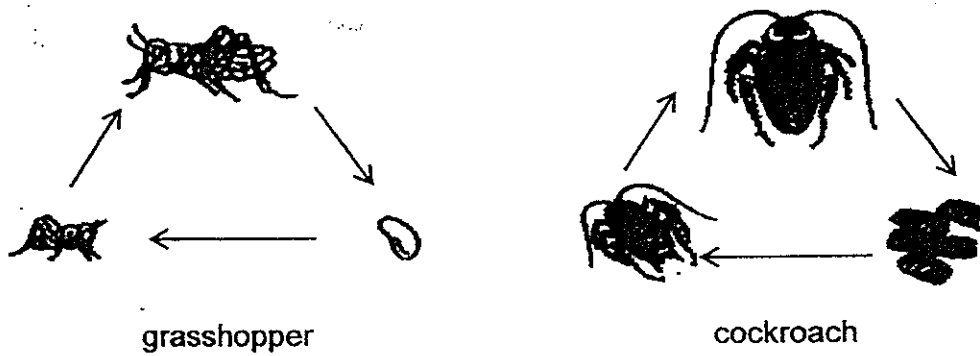

Which of the following statements correctly describe the similarities between the life cycle of a grasshopper and a cockroach?

- A Their young do not have wings.
 - B Their young look like the adults.
 - C They moult a few times as they grow.
 - D Both have three stages in their life cycles.
- (1) A and B only
(2) A, C and D only
(3) B, C and D only
(4) A, B, C and D

- 3 Ali wanted to find out if a fruit could still be developed when a certain part of the flower was removed. The diagram below shows the part of a flower removed from flowers W, X, Y and Z from the same plant.

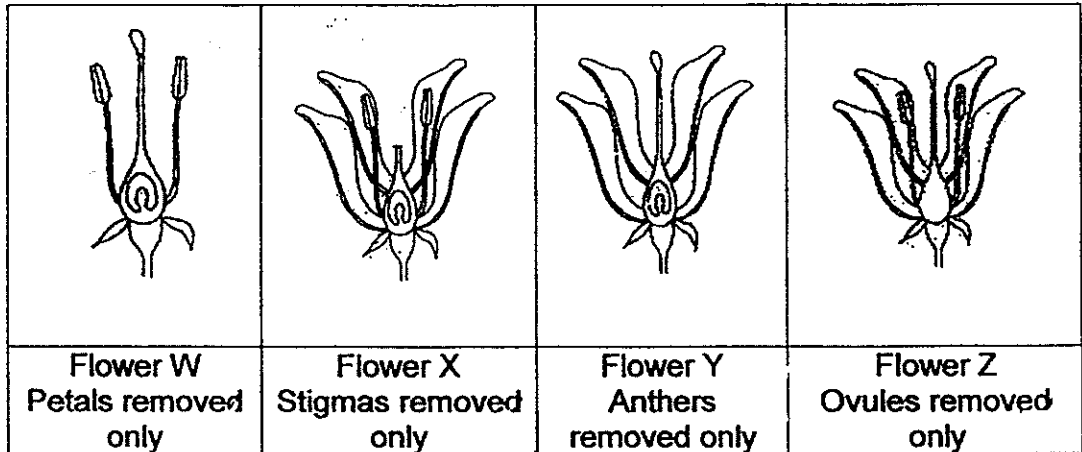

Pollen grains from the same type of flower were dusted over flowers W, X, Y and Z.

Which of the flowers, W, X, Y and Z, will develop into a fruit?

- (1) W only
 - (2) X and Z only
 - (3) W and Y only
 - (4) W, X and Z only
- 4 The diagrams below show four different body systems.

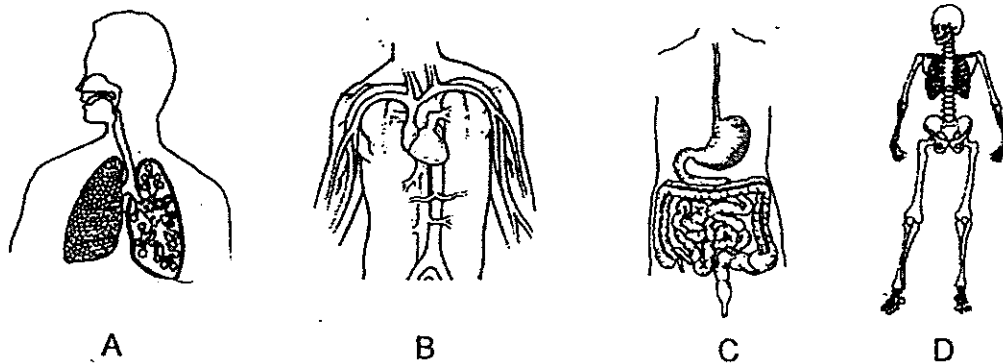

Which of the systems work together to transport oxygen in our bodies?

- (1) A and B only
- (2) A and C only
- (3) B and D only
- (4) C and D only

- 5 The diagrams below show the reproductive parts of a human X and a plant Y.

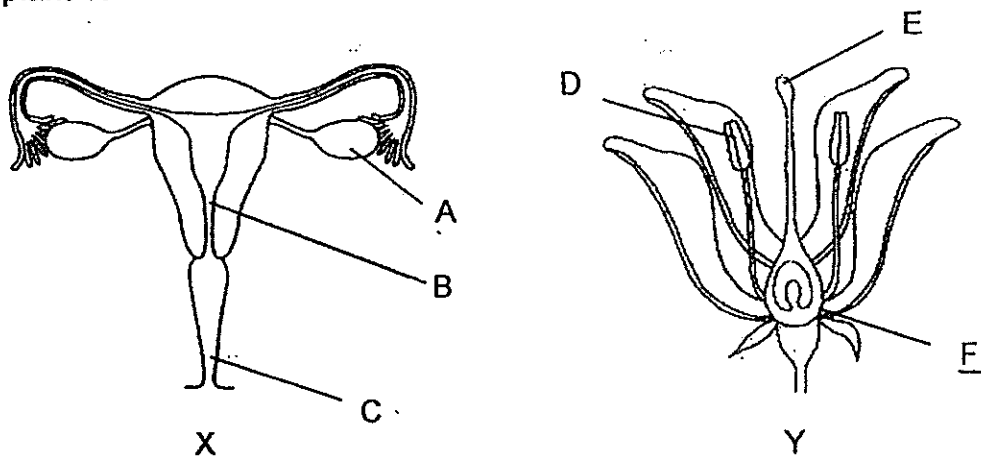

Which one of the following shows where the female sex cells are found in X and Y?

	X	Y
(1)	A	D
(2)	B	F
(3)	C	E
(4)	A	F

- 6 Four friends made some statements about the digestive system.

Bala Digested food is absorbed in the small intestine.

Sam Large intestine stores digested food temporarily.

Peter Food is completely broken down in our stomach.

Minah Our mouth is not part of the digestive system because nothing is digested there.

Who has made the correct statement?

- (1) Bala
- (2) Sam
- (3) Peter
- (4) Minah

7 The diagram below shows Rachel's family tree.

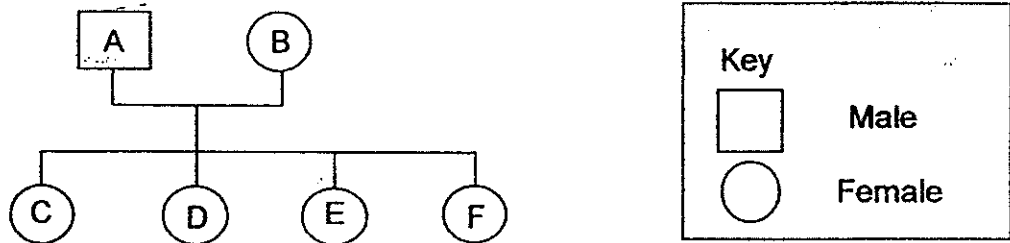

The table below shows the characteristics of her family members and a tick (✓) represents that the person has the characteristic. Rachel resembles her father the most.

Family member	Characteristics			
	Double eyelids	Round face	Hitch-hiker's thumb	Sharp nose
A	✓		✓	
B	✓	✓		✓
C		✓	✓	✓
D	✓	✓		✓
E	✓		✓	✓
F		✓	✓	

Which letter in the family tree best represents Rachel?

- (1) C
- (2) D
- (3) E
- (4) F

- 8 The diagram below is a representation of a blood circulation in a human body. The arrows W, X, Y and Z show the flow of blood to the various parts of the body.

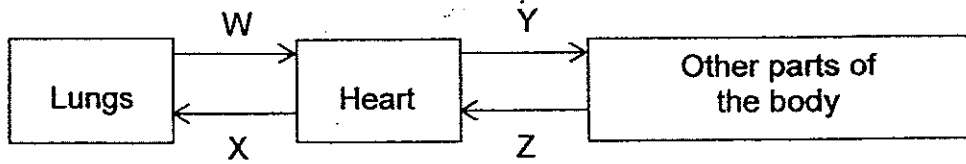

Which one of the following graphs correctly represents the percentage of oxygen in the blood flow at W, X, Y and Z?

(1)

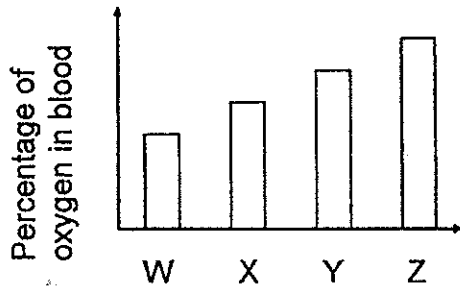

(2)

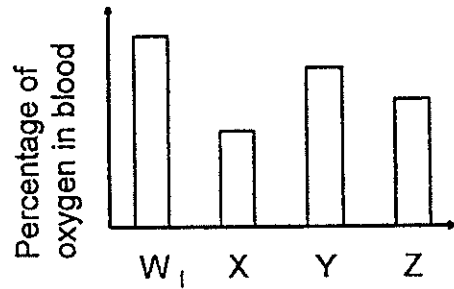

(3)

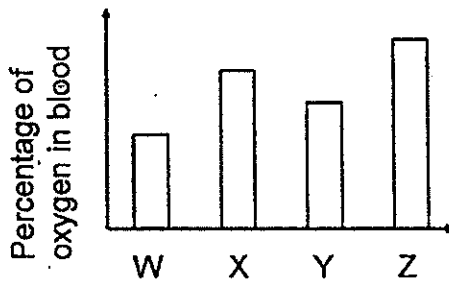

(4)

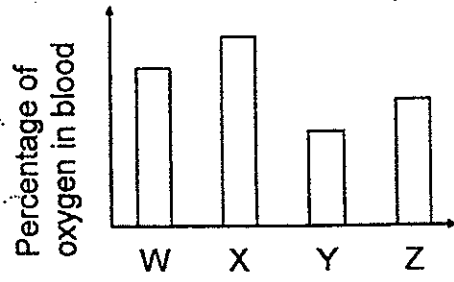

9 Which of the following is/are the function(s) of leaves?

- A Trap sunlight
- B Take in water
- C Carry out photosynthesis
- D Allow the exchange of gases to take place

- (1) A only
- (2) B and C only
- (3) A, C and D only
- (4) B, C and D only

10 In the experiment below, Zara put Plant X into a beaker of red-coloured water. Three days later, she observed that the leaves had turned red.

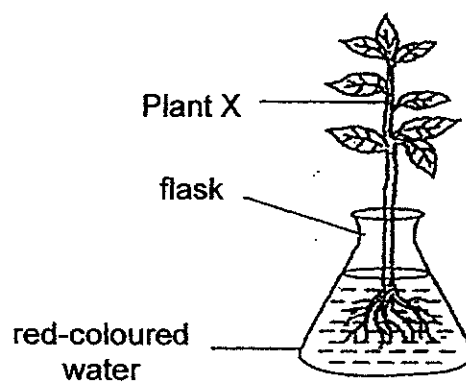

Which of the following statements explain(s) her observation?

- A The roots of Plant X absorbed the red-coloured water.
- B The leaves of Plant X transported the red-coloured water to the roots.
- C The food-carrying tubes of Plant X transported the food to the leaves.
- D The water-carrying tubes of Plant X transported the red-coloured water to the leaves.

- (1) A only
- (2) A and D only
- (3) B and D only
- (4) B, C and D only

- 11 Jean wanted to find out which type of soil was suitable for growing balsam plants. She set up the experiment as shown in the table below.

	Pot A	Pot B	Pot C
Material of pot	plastic	plastic	plastic
Type of soil	garden	sand	clay
Amount of soil	1500 cm ³	1000 cm ³	500 cm ³
Amount of water watered everyday	200 cm ³	200 cm ³	200 cm ³

The 3 pots of similar balsam plants A, B and C were left in her garden.

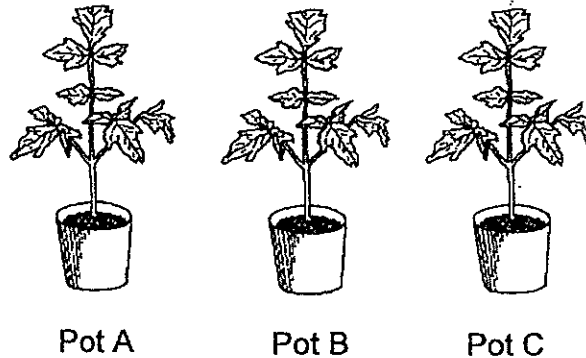

Why was the experiment not a fair one?

- (1) The type of soil in each pot was different.
- (2) The amount of soil in each pot was different.
- (3) The three pots were given the same amount of water.
- (4) The amount of sunlight received by each pot was different.

- 12 The table below shows some information on three cells A, B and C. A tick (✓) indicates the presence of the part of a cell.

	Cell A	Cell B	Cell C
nucleus	✓	✓	✓
cell wall	✓		✓
chloroplast	✓		

Where are cells A, B and C likely to be found?

	Cell A	Cell B	Cell C
(1)	leaf	root	cheek
(2)	root	cheek	leaf
(3)	cheek	leaf	root
(4)	leaf	cheek	root

- 13 Amy placed 2 cells, A and B, in solution S. After an hour, Cell A swelled up and burst but Cell B remained the same.

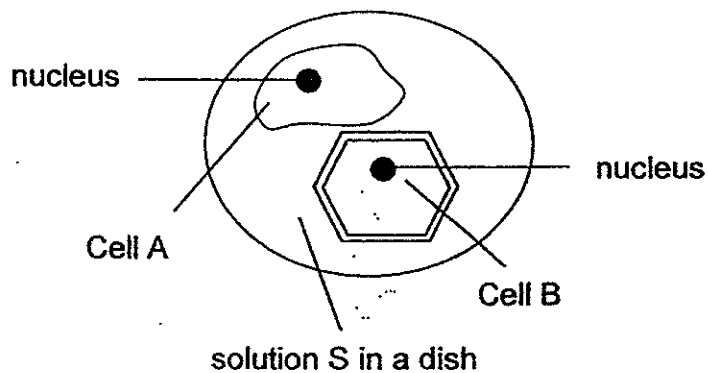

What is the possible reason why Cell B did not swell up like Cell A?

- (1) Cell B has a nucleus which controls the movement of solution S in the cell.
- (2) Cell B has a chloroplast that prevents solution S from entering the cell.
- (3) Cell B has a cell wall that keeps its shape and prevents the cell from swelling up.
- (4) Cell B has a semi-permeable membrane that prevents solution S from entering.

- 14 The diagram below shows a potted plant. A transparent plastic bag containing liquid X is tied around one of the leaves as shown below.

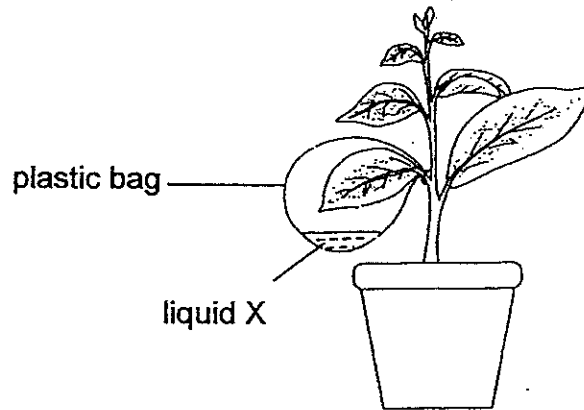

The table below shows the changes in the colour of liquid X with different amounts of carbon dioxide.

Amount of carbon dioxide	Colour
normal	red
more than normal	yellow
less than normal	purple

What colour would the liquid X be at midday and at midnight?

	At midday	At midnight
(1)	purple	yellow
(2)	yellow	purple
(3)	red	yellow
(4)	purple	red

- 15 Bella has two tanks, A and B, each containing a different type of plant as shown in the diagram below. Both tanks were left under a similar light source for five hours. The amount of dissolved oxygen in each tank was measured at the start and the end of the experiment.

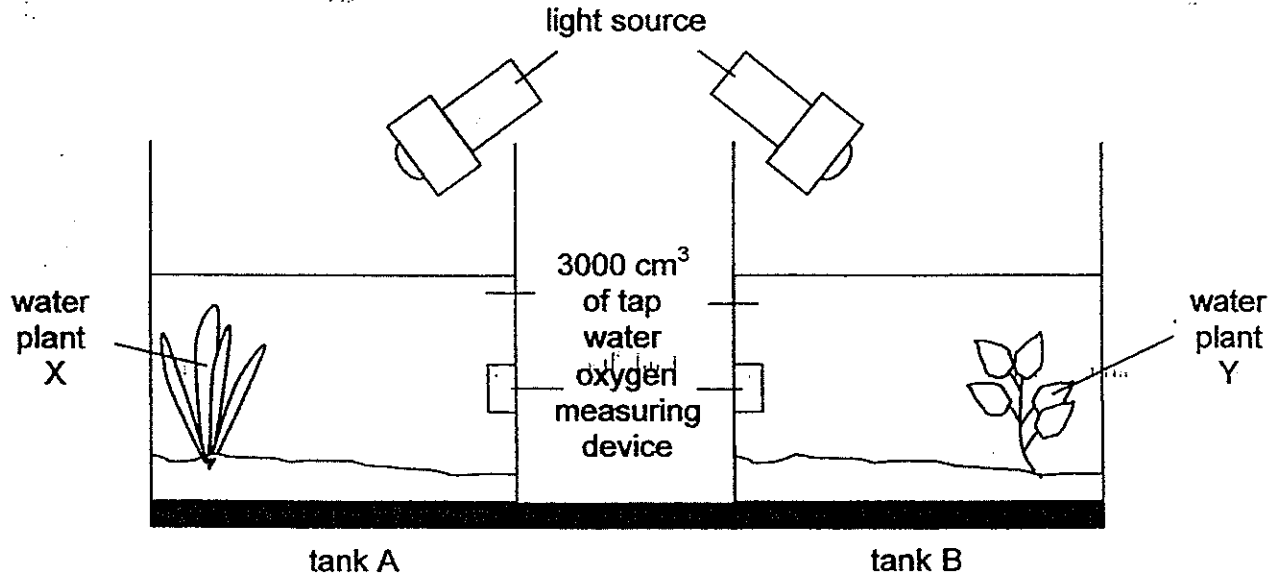

What was Bella trying to find out?

- (1) To find out if carbon dioxide is given out during photosynthesis.
 - (2) To find out if the amount of light affects the rate of photosynthesis.
 - (3) To find out which type of plant has a faster rate of photosynthesis.
 - (4) To find out if different amounts of dissolved oxygen affects the rate of photosynthesis.
- 16 Jennifer studied a community living on a rotting log. She found the following organisms.

ants earthworms moulds mushrooms

Which of the following classifications is correct?

	Decomposers	Organisms that help decomposers
(1)	ants, mushrooms	earthworms, moulds
(2)	moulds, mushrooms	ants, earthworms
(3)	moulds, earthworms	ants, mushrooms
(4)	moulds, mushrooms, earthworms	ants

17 Study the food web below.

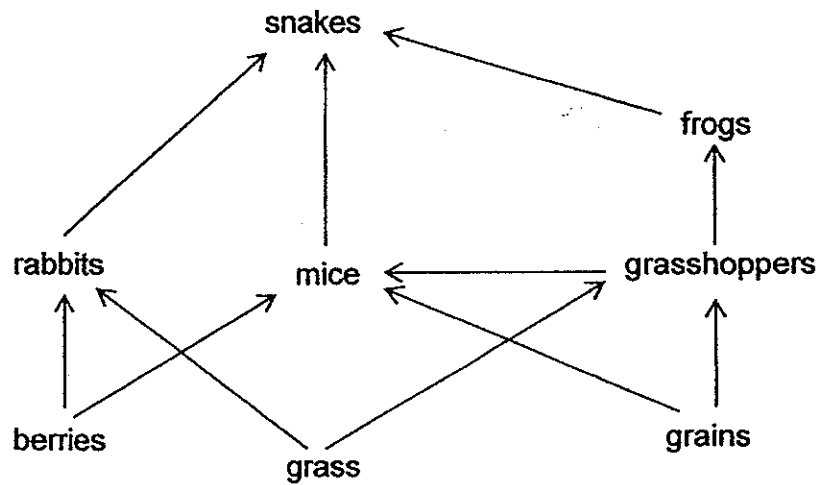

Based on the food web above, which of the following statements are true?

- A Snakes are not preyed on by other predators.
- B There is only one animal that eats plants and animals.
- C There are less than 5 food chains that will end with the snake.
- D Berries, grass and grains transfer the largest amount of energy to the other organisms.

- (1) A, B and C only
- (2) A, B and D only
- (3) A, C and D only
- (4) B, C and D only

- 18 Indra compared the hardness of four tiles A, B, C and D by scratching them with rods made of different materials. She recorded her observations in the table below. A tick (✓) indicates the presence of scratch marks on the tiles.

Rod	Presence of scratch marks			
	Tile A	Tile B	Tile C	Tile D
plastic		✓		
wooden		✓		✓

Which one of the following statements is true?

- (1) B and D are harder than wood.
 - (2) C and D are harder than wood.
 - (3) A and B are harder than plastic.
 - (4) A and C are harder than plastic.
- 19 The diagram below shows how two U-shaped magnets and two bar magnets are arranged.

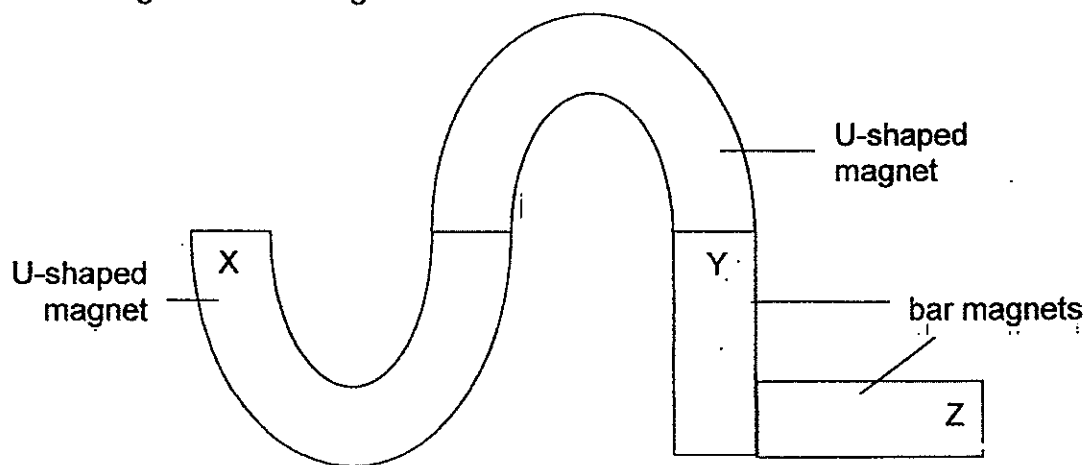

Which of the following shows the possible poles at positions X, Y and Z for the above arrangement?

	Position X	Position Y	Position Z
(1)	North	South	North
(2)	North	North	South
(3)	South	North	South
(4)	South	South	South

- 20 Tricia carried out an experiment to find out the magnetic strength of three magnets, P, Q and R, using the set-up as shown below.

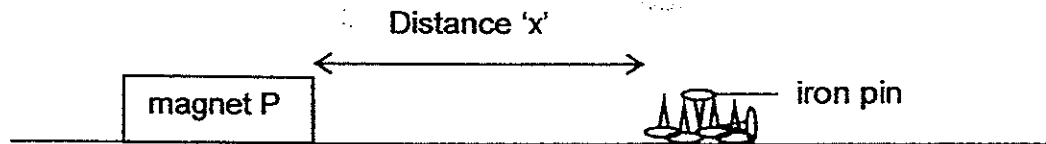

She slowly moved magnet P towards some iron pins until the magnet first attracted the pins from a distance, 'x'. She then repeated the procedure twice and calculated the average distance. The experiment was then repeated with two other magnets, Q and R.

The results are shown in the table below.

Magnet	Distance 'x' (cm)			
	First attempt	Second attempt	Third attempt	Average
P	3.5	4.0	3.9	3.8
Q	1.2	1.5	1.8	1.5
R	2.4	2.2	2.6	2.4

Which one of the following shows the correct order of the magnetic strength of the magnets, P, Q and R, from the weakest to the strongest?

- (1) P, R, Q
- (2) P, Q, R
- (3) Q, R, P
- (4) R, Q, P

- 21 The graph below shows how the temperature of two beakers of water, X and Y, changes over time.

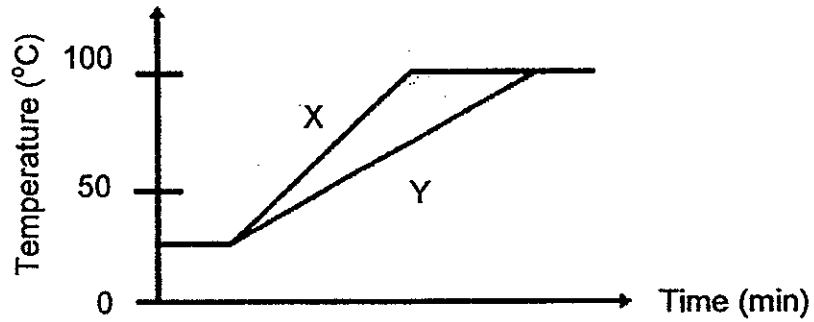

Which one of the following statements describes the graph correctly?

- (1) Beaker X contained less water than Beaker Y.
- (2) Both beakers of water boiled at the same time.
- (3) Beaker X is a poorer conductor of heat than Beaker Y.
- (4) Beaker Y was heated over a stronger flame than Beaker X.

- 22 Study the flow chart below.

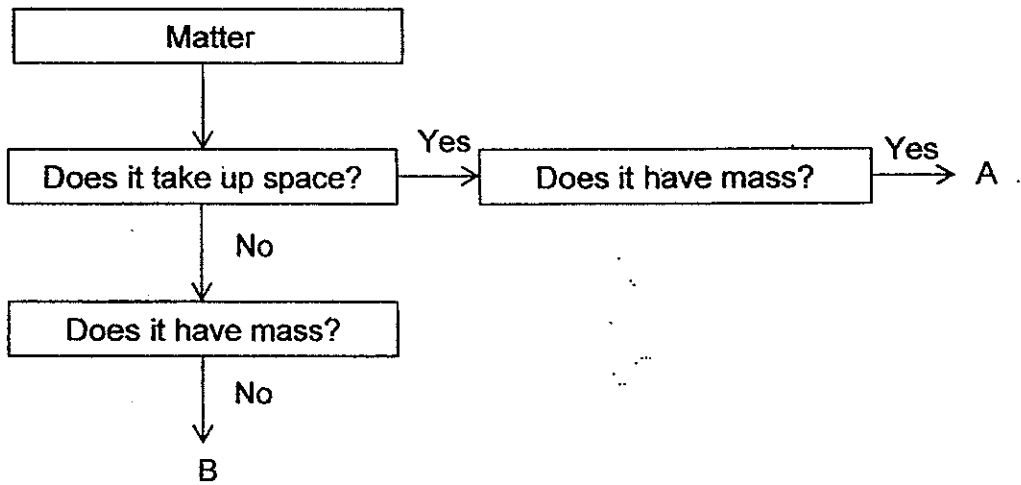

Which of the following represents A and B?

	A	B
(1)	oxygen	rubber band
(2)	pencil	fire
(3)	sound	feather
(4)	light	heat

- 23 Joe conducted an experiment to find out if water or oil is a better conductor of heat.

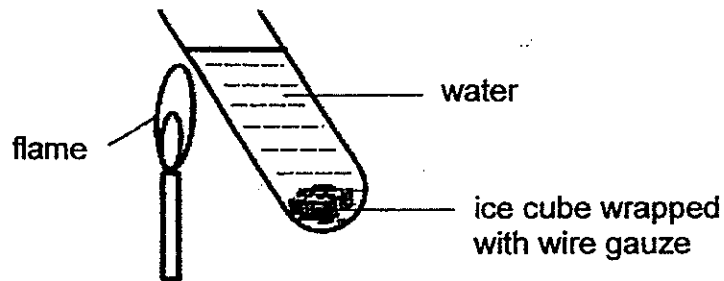

He wrapped a piece of ice cube in wire gauze and placed it at the bottom of the test-tube. Next he put a flame next to the test-tube filled with water as shown above. He then recorded the time taken for the ice cube to melt completely. The experiment was repeated using oil.

Which of the following variables must be kept the same to ensure a fair test?

- A size of the ice cube
- B position of the ice cube
- C time taken for the ice to melt
- D amount of liquid in the test tube

- (1) A and D only
- (2) B and C only
- (3) A, B and D only
- (4) A, B, C and D

24 The diagram below shows three shapes cut out from three different materials of the same size and thickness.

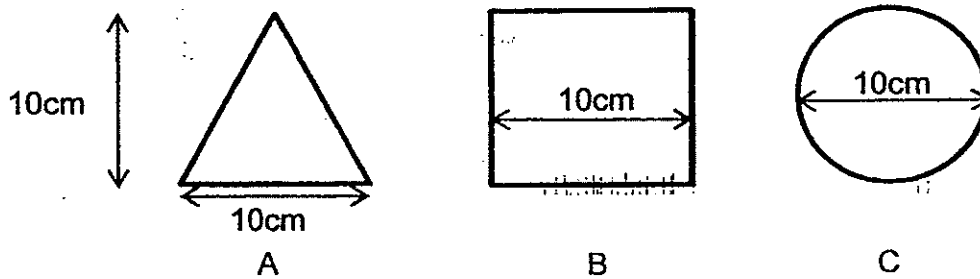

The properties of the three materials are shown below.

Material A	allows some light to pass through
Material B	does not allow light to pass through
Material C	allows most light to pass through

The materials were glued together and placed between a lighted torch and a screen as shown below.

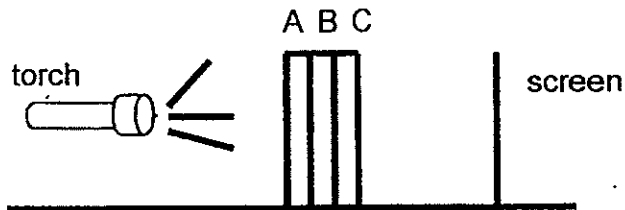

Which one of the following diagrams shows the shadow formed on the screen?



- 25 Zheng Kuang set up the experiment below to find out how quickly water can pass through two different types of soil, A and B.

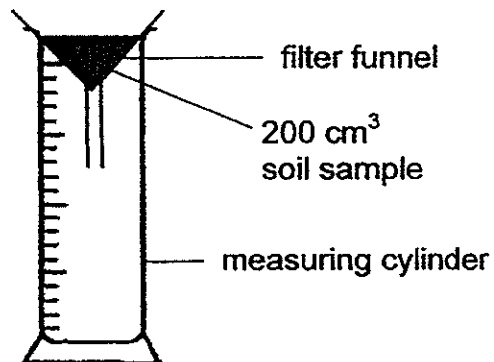

The time taken for the water to pass through each type of soil was measured and recorded in the table below.

Type of soil	Soil A	Soil B
Time taken (s)	15	40

Which one of the following correctly represents the properties of Soil A and Soil B?

	Size of soil particles	Size of air spaces
(1)	Larger in A than B	Smaller in A than B
(2)	Larger in A than B	Larger in A than B
(3)	Smaller in A than B	Larger in A than B
(4)	Smaller in A than B	Larger in B than A

26 The diagram below shows the water cycle.

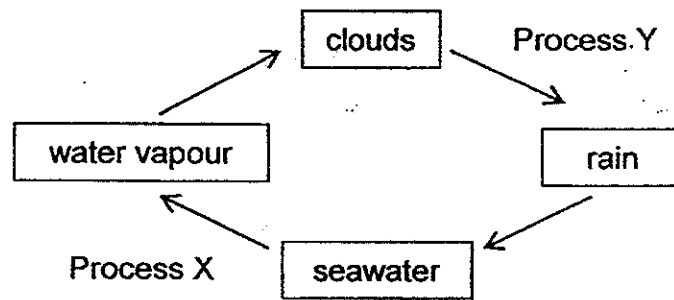

Which of the following correctly describe(s) the processes X and Y in the diagram above?

- A Process X takes place all the time.
- B Heat is lost by the water vapour during Process Y.
- C Process X does not take place at a fixed temperature.

- (1) A only
- (2) A and C only
- (3) B and C only
- (4) A, B and C

27 David poured 200ml of water into two identical containers, X and Y, and left them outdoors. Five hours later, he found that there was less water left in container X than container Y as shown below.

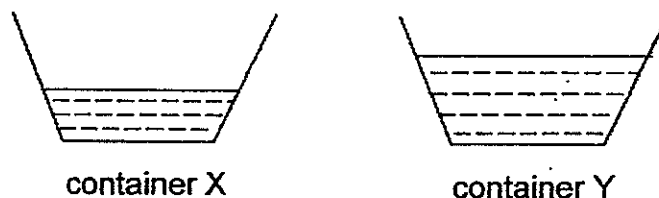

Which of the following could explain the difference in the water level?

- A Container X was left at a more windy place.
- B Container X was left at a place with more sunlight.
- C Container X was left at a place with lower temperature.
- D Container X was filled with water at a higher temperature.

- (1) A and C only
- (2) B and D only
- (3) A, B and D only
- (4) B, C and D only

28 The diagram below shows an open circuit.

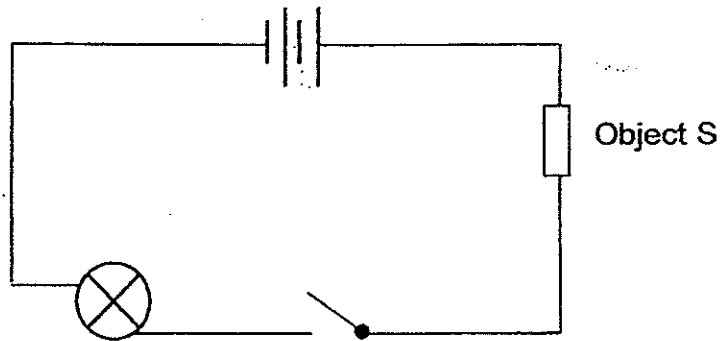

When the circuit is closed, the light bulb does not light up at all.
What could be the possible reasons?

- A The light bulb has fused.
- B Object S is a plastic ruler.
- C The batteries are not connected properly.
- D The wires are only connected to the metal casing of the bulb.

- (1) A and B only
- (2) A, C and D only
- (3) B, C and D only
- (4) A, B, C and D

29 Look at the set-up below.

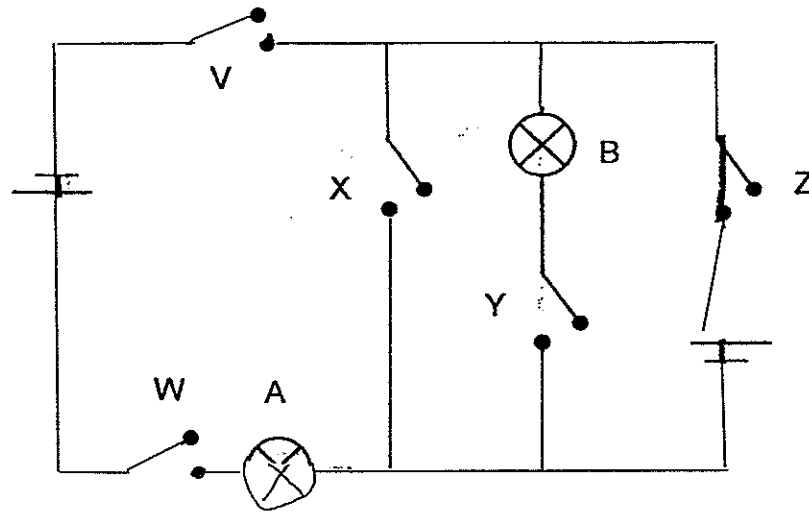

Which of the switches, V, W, X, Y and Z, should be open or closed so that both bulbs A and B light up at the same time?

		Switch				
		V	W	X	Y	Z
(1)		closed	closed	open	open	closed
(2)		closed	closed	open	closed	open
(3)		open	open	closed	open	open
(4)		open	open	closed	closed	closed

30 Rachel wanted to find out which material, A, B, C or D, is a conductor of electricity.

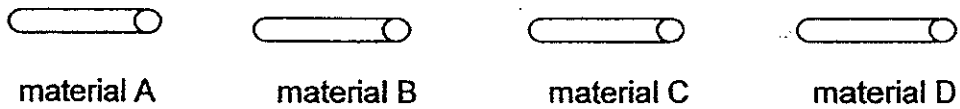

She set up an electrical circuit as shown below.

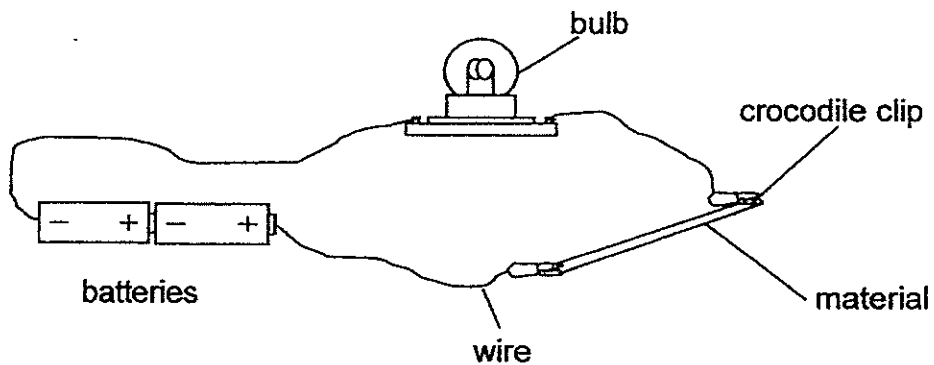

Rachel recorded the results in the table below.

Material	Does the bulb light up?
A	No
B	Yes
C	No
D	Yes

Which of the following shows what materials A, B, C and D are?

	A	B	C	D
(1)	steel	iron	paper	fabric
(2)	fabric	ceramic	plastic	carbon
(3)	copper	steel	glass	diamond
(4)	ceramic	iron	rubber	copper

End of Booklet A





**CATHOLIC HIGH SCHOOL
SEMESTRAL ASSESSMENT 2
2014
PRIMARY FIVE**

SCIENCE

BOOKLET B

Name: _____

Class: Primary 5 - _____

Date: 29 October 2014

Parent's Signature: _____

Booklet A	60
Booklet B	40
Total	100

14 questions

40 marks

Total Time for Booklets A and B: 1 hour 45 minutes

INSTRUCTIONS TO CANDIDATES

Do not turn over this page until you are told to do so.

Follow all instructions carefully.

Answer all questions.

Write your answers in this booklet.

This booklet consists of 15 printed pages, excluding cover page.

Booklet B (40 marks)

For questions 31 to 44, write your answers in this booklet.

The number of marks available is shown in brackets [] at the end of each question or part question. (40 marks)

- 31 Mr Tan carried out an investigation in his farm with a particular fruit-bearing plant. He grew the plants in four similar fertile plots of land of equal size. He watered the plants every day with the same amount of water. After eight months, he calculated the average number of fruits produced per plant in each plot.

Plot	Number of plants per plot	Average number of fruits per plant
A	40	7
B	30	16
C	20	24
D	10	30

- (a) What was Mr Tan trying to find out? [1]

- (b) Name a variable that Mr Tan needs to keep constant to ensure that the experiment is a fair one. [1]

- (c) Explain the result observed in Plot A. [1]

(Go on to the next page)

SCORE	3
-------	---

32 Ryan counted the number of two different types of young plants, X and Y, at various distances from their parent plants in a garden. The results are shown in the graph below.

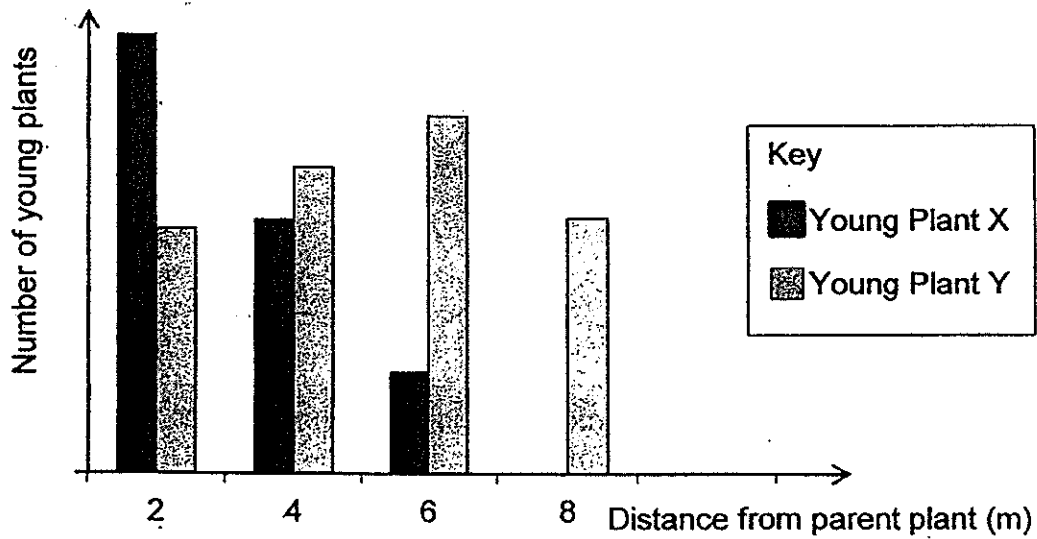

Which one of the following is likely to be the fruit of Plant X?
Choose your answer and tick (✓) in the corresponding box.

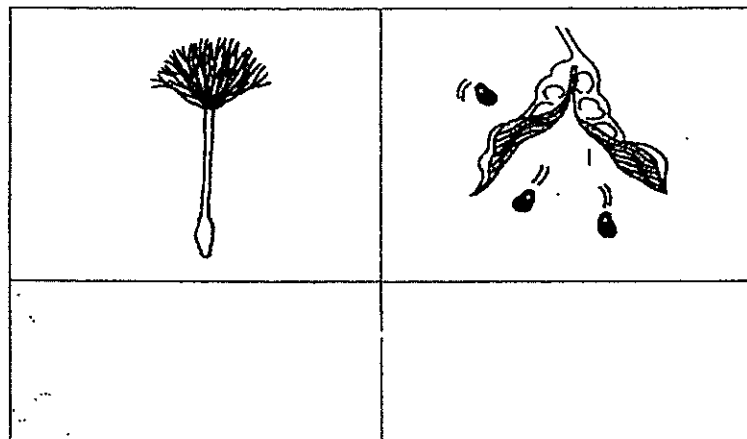

Explain your answer.

[2]

(Go on to the next page)

SCORE	2
-------	---

- 33 Muthu wanted to find out if vegetables are digested faster than meat. He placed 200g of vegetables and 200g of chicken meat into identical flasks, each containing 300ml of digestive juice, and left them in the laboratory for 4 hours.

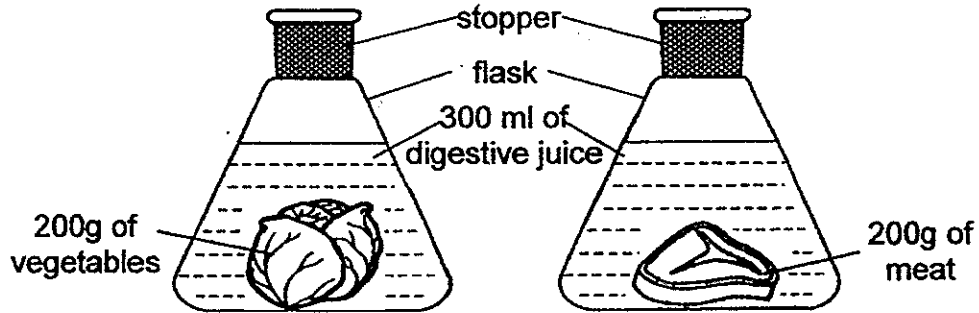

- (a) What does Muthu need to measure and record in order to arrive at the conclusion for the experiment? [1]

- (b) In which part of the human digestive system is water removed from the undigested food? [1]

(Go on to the next page)

SCORE	2
-------	---

- 34 Ismail wanted to find out if roots take in water. He set up the experiment below and recorded the water level in the beaker over 5 days.

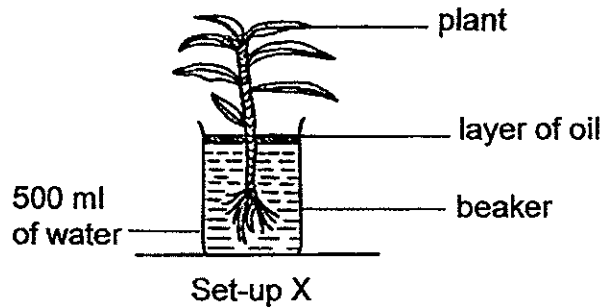

- (a) In the box provided below, draw and label a suitable control for the experiment above. [1]

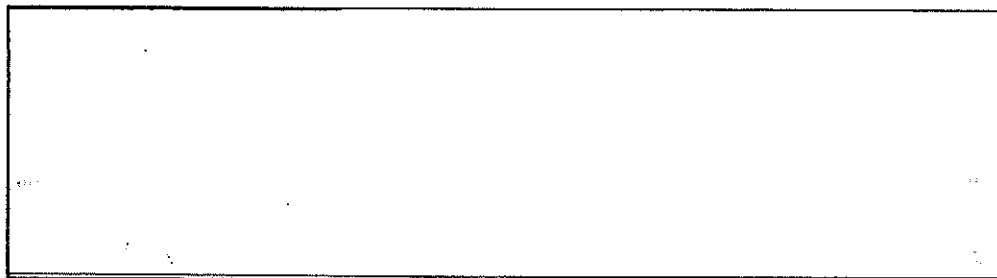

- (b) What is the purpose of setting up a control? [1]

After 5 days, Ismail plotted a graph below to represent his results.

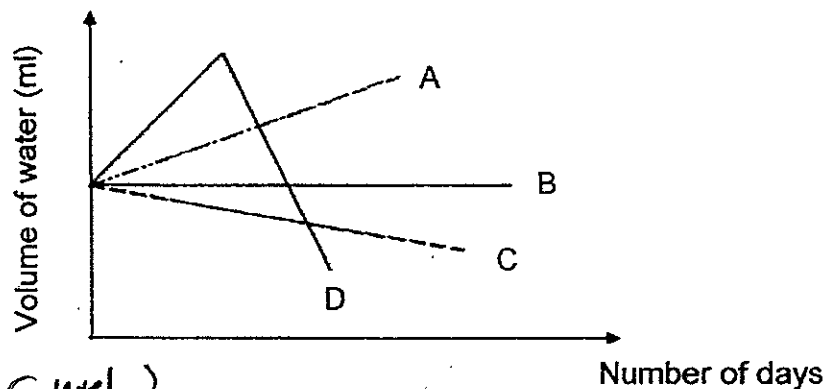

- (c) Which one of the lines, A, B, C or D, represents the volume of water in Set-up X after 5 days? Explain your answer. [1]

(Go on to the next page)

SCORE	3
-------	---

35 The diagram below shows three different groups of cells,

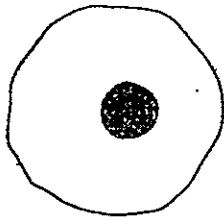

A

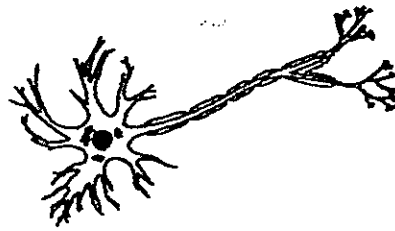

B



C

- (a) Which of these cells, A, B and C, is a plant cell?
Give a reason for your answer.

[1]

- (b) The nucleus controls all activities of the cell. State one other function of the nucleus.

[1]

(Go on to the next page)

SCORE	2
-------	---

36 Evelyn set up an experiment as shown in the diagram below.

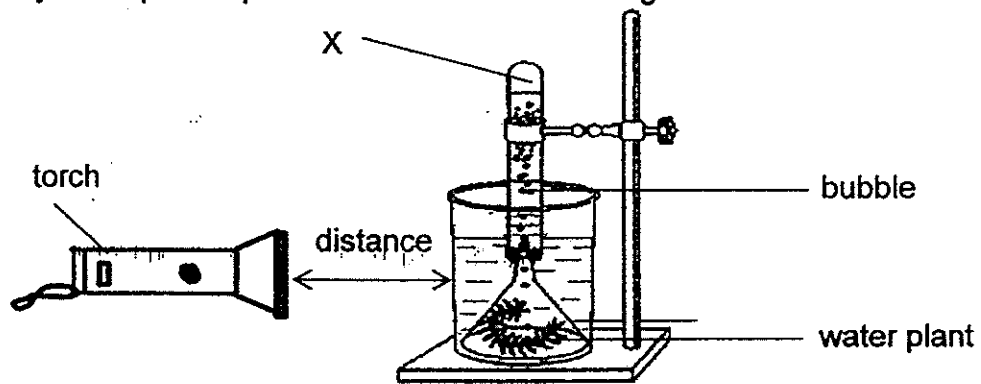

She placed a colourless, transparent filter in front of the torch and counted the number of bubbles produced in an hour. The plant produced 21 bubbles in an hour. She repeated the experiment by changing the colour of the filter. She recorded the results in the table below.

Type of filter	Number of bubbles per hour
A	19
B	15
C	0
D	10
E	19

(a) What was Evelyn trying to find out from her experiment? [1]

(b) After some time, Evelyn realised that fewer bubbles were produced for all the filters. Give a reason for her observation.

(c) Evelyn repeated her experiment by adjusting the set-up without introducing or removing anything from the set-up. The plant produced 28 bubbles in an hour when she placed a colourless, transparent filter in front of the torch. What could Evelyn have done? Explain your answer. [2]

(Go on to the next page)

SCORE	4
-------	---

37 There are 3 types of animals A, B and C in a farm. One of the animals is a plant-eater. The animals have sufficient water and air. The 2 graphs below show the changes in their populations over time.

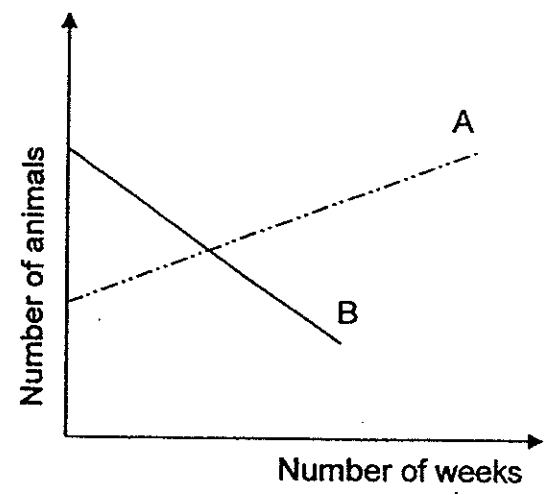
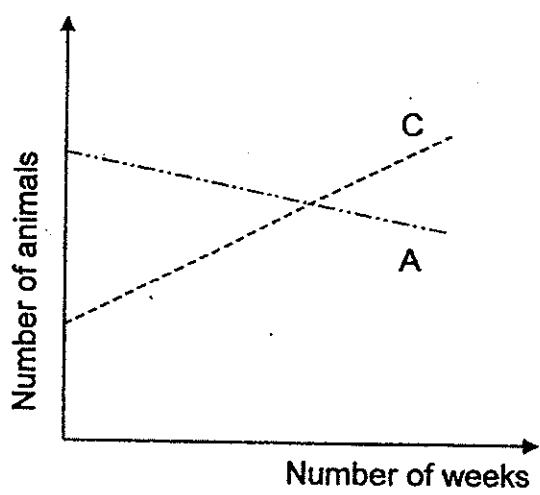

(a) Using the above information, construct a possible food chain if the 3 animals were placed together in another tank with a plant. [1]

(b) Based on the graphs, what would happen if the population of organism A is removed? [2]

(Go on to the next page)

SCORE	3
-------	---

- 38 Three types of materials W, X and Y of equal mass were placed in the funnels as shown in the diagram below. 600cm^3 of water was poured into each funnel at the same time.

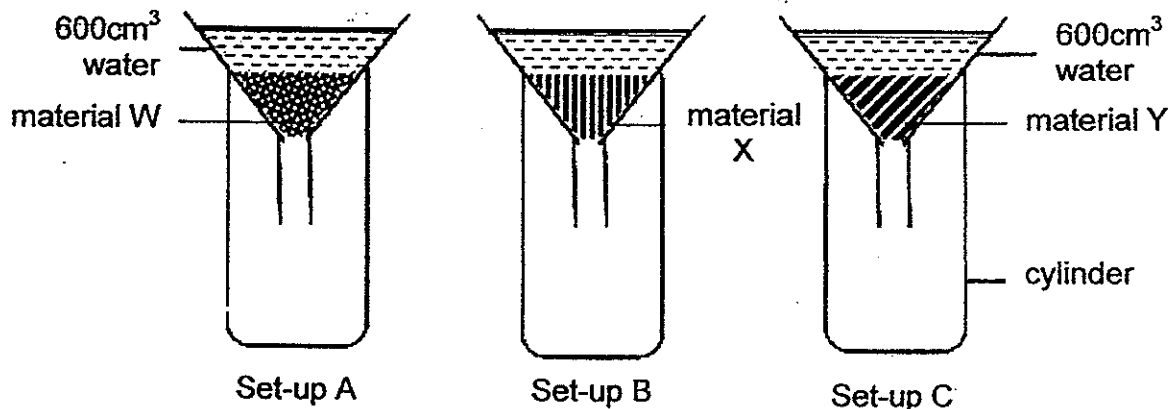

After 5 minutes, the volume of water in each cylinder was measured and the results were recorded in the table below.

Set-up	Material	Volume of water (cm^3) in the cylinder
		After 5 minutes
A	W	540
B	X	250
C	Y	600

- (a) Based on the results above, what can you tell about Materials W, X and Y? [1]

- (b) Which material will be most suitable to be made into a diaper? Explain your answer. [1]

(Go on to the next page)

SCORE	2
-------	---

39 Ahmad had four metal bars W, X, Y and Z. He carried out an experiment with the four bars and recorded his findings in his Science Journal.

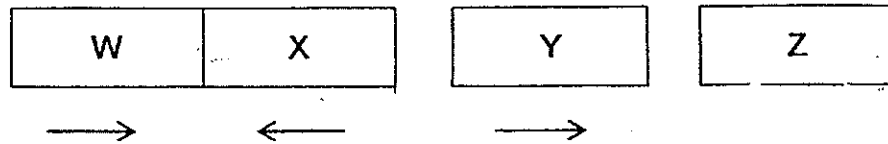

- Bar W was attracted to Bar X.
- Bar Y was attracted to Bar W.
- Bar X repelled Bar Y.
- There was no attraction or repulsion between Bar Y and Bar Z.

(a) From Ahmad's findings, what do you think were Bars X and Y? [1]

(b) Explain your answer in (a). [1]

(c) Which bar was made of gold? Why? [1]

(Go on to the next page)

SCORE	3
-------	---

- 40 Kasini carried out the following experiment in her kitchen. She left a glass of hot water sealed with plastic wrap, on the table. After a while, she saw water droplets forming on the underside of the plastic wrap.

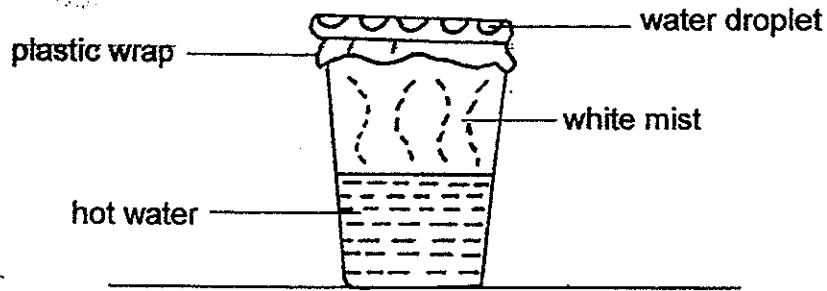

The hot water in the experiment changes from one state to another as shown by the flowchart below.

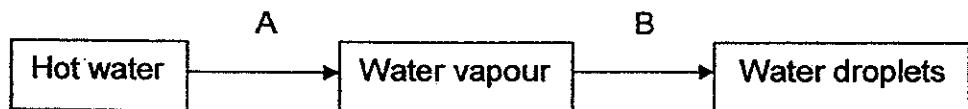

- (a) Name the processes A and B. [1]

(i) A: _____

(ii) B: _____

Kasini repeated the experiment with a sealed glass of water with ice cubes.

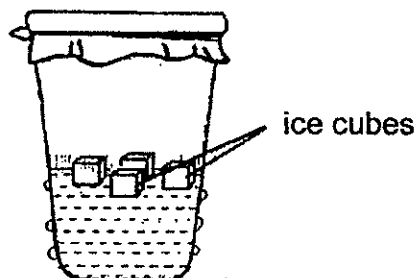

- (b) Draw water droplets on the diagram above to show where the droplets would be formed. [1]

- (c) Explain your answer. [1]

(Go on to the next page)

SCORE	3
-------	---

- 41 Matthew conducted an experiment to compare the heat conductivity of materials, P, Q and R. He placed material P under the beaker of water before heating it as shown in the diagram below. He then recorded the time taken for the water to boil.

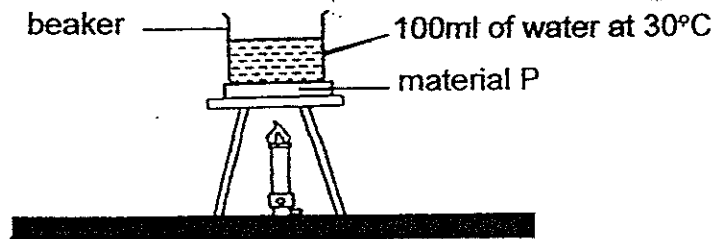

He repeated the experiment using materials, Q and R. The graph below shows the results he collected.

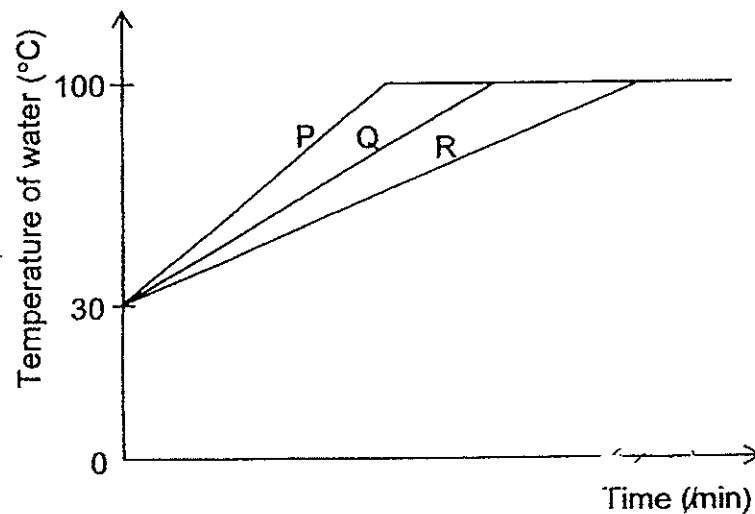

- (a) Give a reason why the amount of water in the beaker, must be kept the same. [1]

- (b) What can you conclude about the heat conductivity of the three materials, P, Q and R? [1]

(Go on to the next page)

SCORE	2
-------	---

- 42 The set-up below uses a light sensor to count the number of identical object X on a moving belt.

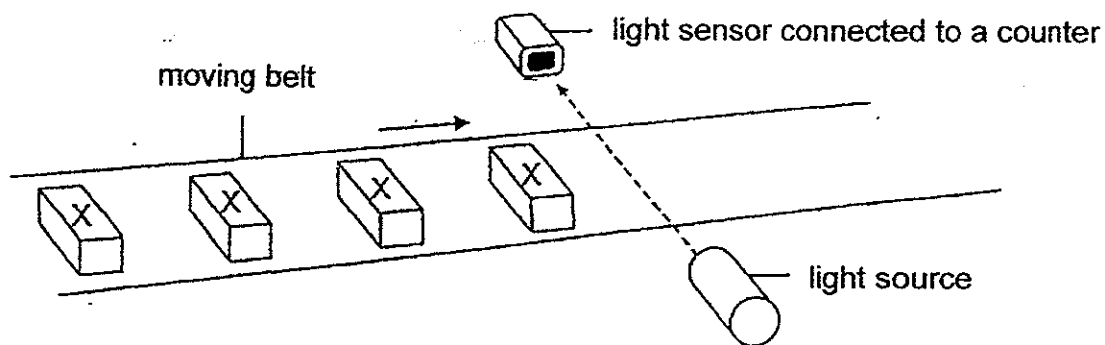

The belt moves at a constant speed. When an object X is between the light source and sensor, it blocks the light from reaching the sensor. The data recorded is shown in the graph below.

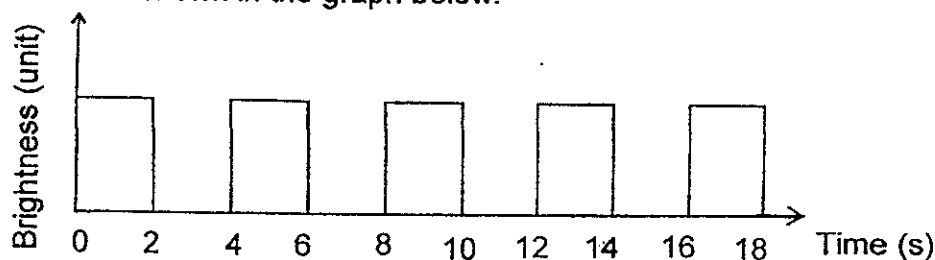

- (a) Based on the graph, how many object X passed the sensor in 18 seconds? [1]

- (b) The light source and the sensor are placed 3 cm above the belt. Can an object that is less than 3 cm in height be detected? Give a reason for your answer. [1]

- (c) The set-up shown above can count 20 object X in a minute when the belt is moving at its maximum speed. Suggest one way to count more than 20 object X in a minute without changing the speed of the belt. [1]

(Go on to the next page)

SCORE	3
-------	---

- 43 Containers A and B, each made of a different material, were filled with the same amount of water at 5°C at the same time. Container A felt colder than B when touched.

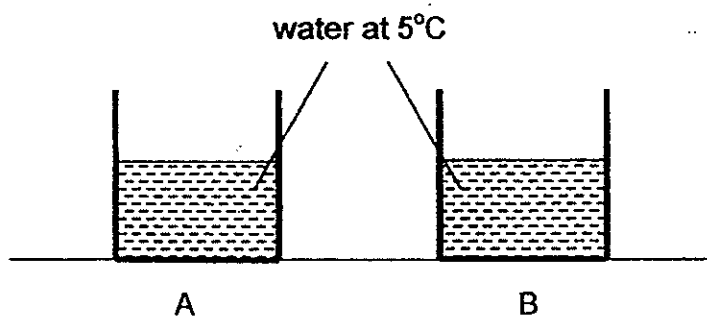

Both containers were left in a classroom at 25°C . The temperature of water in the beaker was measured every five minutes. The table below shows the temperature of water in Container B over a period of 20 minutes.

Time (min)	0	5	10	15	20
Temperature of water in Container B ($^{\circ}\text{C}$)	5	8	11	14	18

- (a) Would the temperature of water in Container A at the 20th minute be more than, less than or equal to 18°C ? [1]

- (b) Explain your answer in (a). [1]

(Go on to the next page)

SCORE	2
-------	---

(c) (Continue from Question 43)

The graph below shows the temperature changes of the water in the beakers over a period of time. The line that shows the changes in the temperature of water in Container B has been drawn for you.

(i) Label the x-axis and y-axis clearly in the boxes provided. [1]

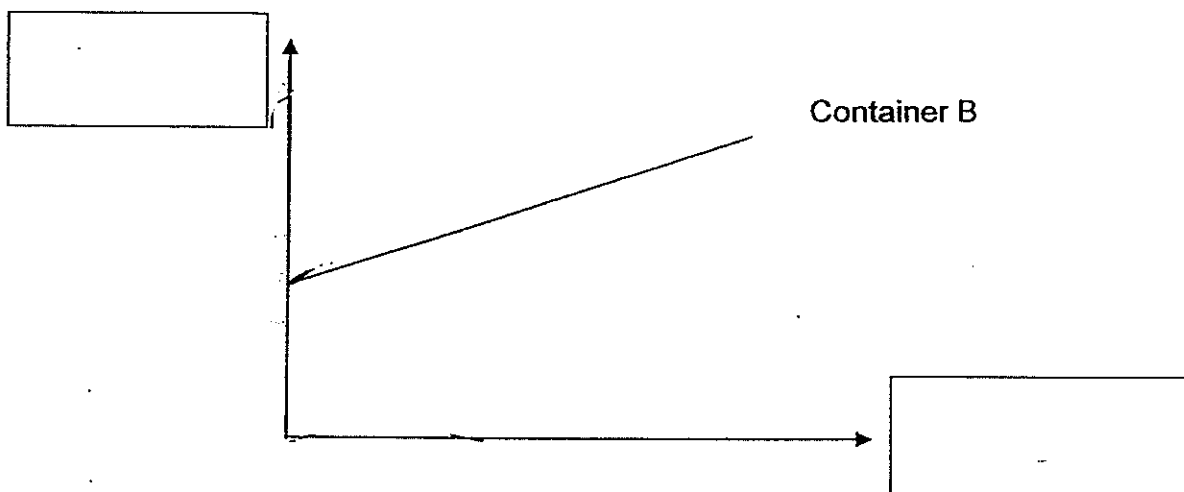

(ii) Draw and label a line in the graph above to show the changes in the temperature of water in Container A over time. [1]

(d) Which container, A or B, would be more suitable to use as a lunchbox to keep food warm? Explain your answer. [1]

(Go on to the next page)

SCORE	3
-------	---

- 44 Susan was given 3 rods of different materials A, B and C to test whether they could conduct electricity. She joined them together and connected them to an electric circuit as shown in the diagram below.

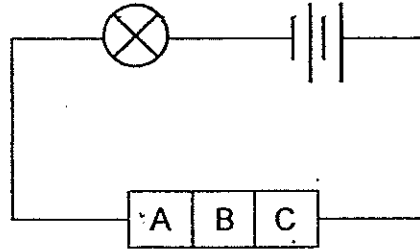

Test 1

She observed that the bulb did not light up. Keeping the rest of the circuit unchanged, she re-arranged the order of the materials in the circuit two more times according to the order shown in the diagram below.

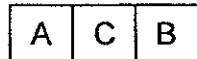

Test 2

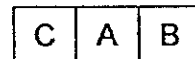

Test 3

- (a) In the table below, indicate whether the bulb will light up for Test 2 and Test 3. [1]

	Will the bulb light up? (State Yes or No)
Test 2	
Test 3	

- (b) Using two batteries, one bulb and all the three rods, Susan then re-arranged the electric circuit so that the bulb might light up. Draw the circuit diagram, using circuit symbols, of one such possible arrangement, in the box below. [2]

EXAM PAPERS 2014

SCHOOL: CATHOLIC HIGH SCHOOL
SUBJECT: SCIENCE
LEVEL: PRIMARY 5
TERM: SA 2

BOOKLET A

Q1	Q2	Q3	Q4	Q5	Q6	Q7	Q8	Q9	Q10
4	3	3	1	4	1	3	2	3	2
Q11	Q12	Q13	Q14	Q15	Q16	Q17	Q18	Q19	Q20
2	4	3	1	3	2	2	4	2	3
Q21	Q22	Q23	Q24	Q25	Q26	Q27	Q28	Q29	Q30
1	2	3	4	2	2	3	4	2	4

BOOKLET B

- Q31 a) He was trying to find out if the number of plants per plot affects the average number of fruits per plant.
b) The type of soil must be the same.
c) There is overcrowding, so each plant does not have enough water and air, so the average number of fruits per plant is lower than usual.
- Q32 As the distance of the young plants from the parent plant increases, the number of plants decreases. Plant X is dispersed by splitting as most young plants were found near the parent plant.
- Q33 a) He needs to measure the amount of food after the experiment.
b) Large intestine.
- Q34 a)

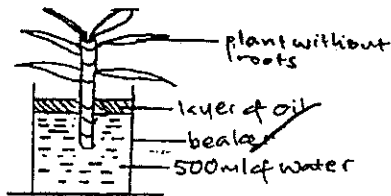

- b) To compare with X and to confirm that water loss in the beaker is solely due to the roots taking in water and nothing else.
c) C. The water level will decrease as the roots will slowly take in the water in the beaker for life processes such as photosynthesis.
- Q35 a) C. It has a cell wall which is in a plant cell but A and B do not have cell walls.
b) The nucleus carries genetic information to be passed down from one generation to another.
- Q36 a) To find out if the type of filter used affects the rate of photosynthesis.
b) The amount of dissolved carbon dioxide in the water in the beaker has decreased as the plant has used up most of it for photosynthesis, so photosynthesis takes place at a slower rate.

c) She moved the torch closer to the plant. When the intensity of light increases, photosynthesis takes place at a faster rate.

Q37 a) plant \rightarrow B \rightarrow A \rightarrow C

b) The population of B will increase. The population of C will decrease and eventually there is more C. The population of plants decreases.

Q38 a) X is the most absorbent as it has the least amount of water collected in the cylinder followed by W and Y.

b) X. It is the most absorbent and will absorb as much of the child's urine as possible and urine will not leak out quickly and easily.

Q39 a) Magnets.

b) Only magnets can repel each other when their like poles are facing each other, and X and Y repelled each other, so they are magnets.

c) Z. Gold is not a magnetic material, so it will not attract or repel any magnet and Z did not attract and repel Y, which is a magnet.

Q40 a)(i) A: evaporation (ii) B: condensation

b)

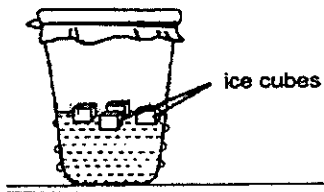

c) The warm water vapour from the surroundings touch and then lose heat to the cooler surface of the glass containing the ice water, condense and form tiny water droplets.

Q41 a) So that the difference in increase of temperature of water taken to boil is solely due to the different heat conductivity of the material, and nothing else.

b) P is the best conductor of heat, followed by Q then R.

Q42 a) 4.

b) No. The path of light will not be blocked by the object, so the object will not be detected as the light sensor can still sense the light.

c) Move the objects closer to each other.

Q43 a) More.

b) A is a better conductor of heat than B, so heat pass through A faster than B to heat up the water, so A will gain heat faster than B.

d) B. B is a poorer conductor of heat and loses heat more slowly than A to the surrounding.

Q44 a) No. No.

b)

