

METHODIST GIRLS' SCHOOL (PRIMARY)

Founded in 1887



PRIMARY 3 END-OF-YEAR EXAMINATION 2009 SCIENCE

BOOKLET A

Total Time : 1 hour 45 minutes

INSTRUCTIONS TO CANDIDATES

Do not open the booklet until you are told to do so.
Follow all instructions carefully.
Answer all questions.

Name: _____ ()

Class: Primary 3. _____

Date: 12 October 2009

Booklet A	/ 50
Booklet B	/ 40
Practical Test	/ 10
TOTAL	/ 100

This booklet consists of 11 printed pages.

Section A : (25 x 2 marks)

For each question, four options are given. Choose the most suitable option and shade your answer in the Optical Answer Sheet (OAS) provided.

1. John made a comparison between a snake and a turtle.



He wrote down the following statements.
Which of the following statements are correct?

- A: They lay eggs.
- B: They have gills.
- C: They have scales.
- D: They move with flippers.

- (1) A and C only
- (2) B and C only
- (3) A and D only
- (4) B and D only

2. Study the classification table below.

Group A	Group B
Angel fish	Molly
Seahorse	Guppy
Puffer fish	Swordtail

Which one of the following sets of headings for Group A and Group B is correct?

	Group A	Group B
<input checked="" type="radio"/> (1)	Fish with scales	Fish without scales
<input type="radio"/> (2)	Fish that feeds on animals	Fish that feed on plants
<input type="radio"/> (3)	Fish that lay eggs	Fish that give birth to young alive
<input type="radio"/> (4)	Fish that breathe with lungs	Fish that breathe with gills

3. Study the classification table below.

Animals			
Group A	Group B	Group C	Group D
crow	rabbit	snake	seal
sparrow	kangaroo	worm	dolphin

The animals are grouped according to _____

- 1 how they move
 2 what they feed on
 3 their body coverings
 4 the number of stages in their life cycle
4. The Venus flytrap captures insects by snapping its two leaves shut like a shell when an insect walks on it. The diagram below shows how a Venus flytrap captures its prey.

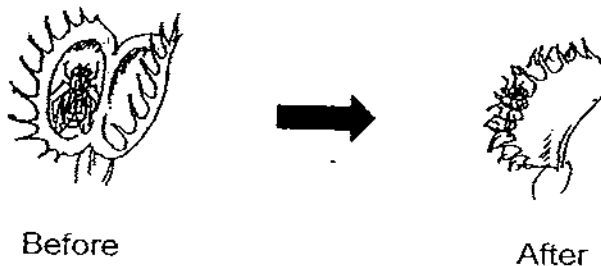

What characteristics of living things are best described by the reaction of the Venus flytrap?

- A Living things can respond to touch.
 B Living things can move by themselves.
 C Living things can grow and reproduce.
 D Living things need air, food and water for survival.
- 1 A and B only
 2 C and D only
 3 A, B and D only
 4 B, C and D only

5. Some angelfish, plastic plants and coloured stones were put into an aquarium. The number of fishes, plants and stones found in the aquarium for the next thirty weeks is shown in the table below.

Things	Angelfish	Plastic plants	Coloured stones
Week 0	20	20	50
Week 10	25	20	50
Week 20	32	20	50
Week 30	38	20	50

What can you conclude from the given table?

- (1) Only living things can grow.
 (2) Only living things can reproduce.
 (3) Only living things can move by themselves.
 (4) Only living things can make their own food.
6. Which one of the following objects is made from things that were once alive?

- (1) door bell
 (2) spectacles
 (3) ceramic vase
 (4) cardboard box

7. Study the concept map below.

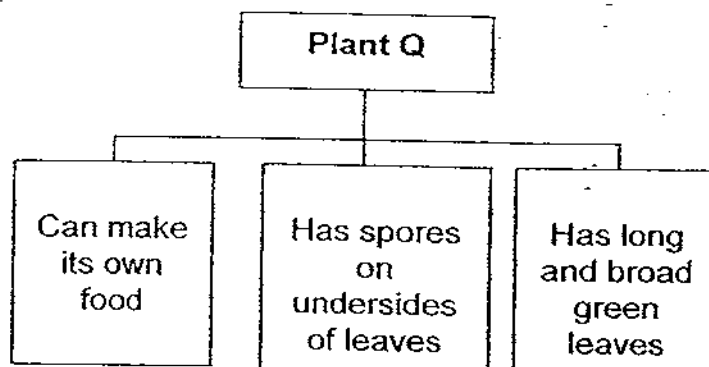

Which of the following is most likely to be Plant Q?

- (1) moss
 (2) toadstool
 (3) mushroom
 (4) bird's nest fern

8. Which of the following is a similarity between a tomato seed and a mango seed?

- A: The seeds are protected by the fruit.
- B: The seeds can develop into new plants.
- C: The seeds only need air and warmth to germinate.
- D: The seeds take the same period of time to grow into an adult plant.

- (1) A and B only
- (2) C and D only
- (3) A, B and C only
- (4) B, C and D only

9. Which of the following is a similarity between a bacteria and fungi?

- (1) They reproduce by spores.
- (2) They can make their own food.
- (3) They can be useful or harmful to humans.
- (4) They can only be viewed under the microscope.

10. The diagram below shows the stages of growth of a tadpole. Arrange them in order of development.

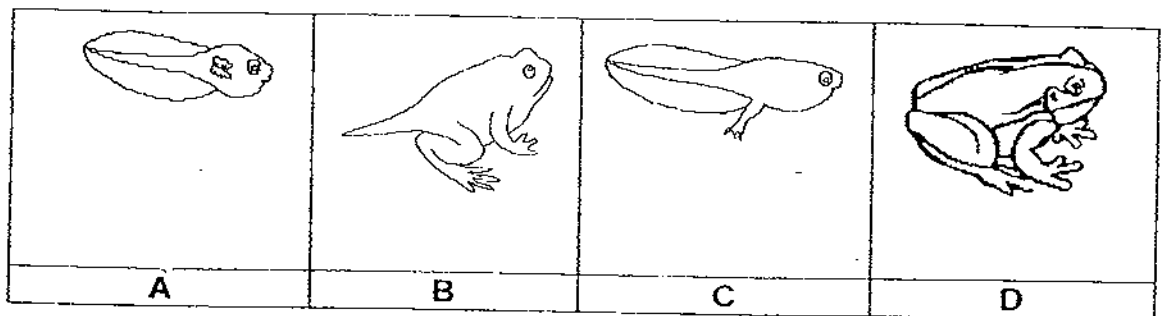

- (1) A → B → C → D
- (2) B → D → C → A
- (3) C → A → D → B
- (4) A → C → B → D

11. The diagrams below show the life cycles of two different animals.

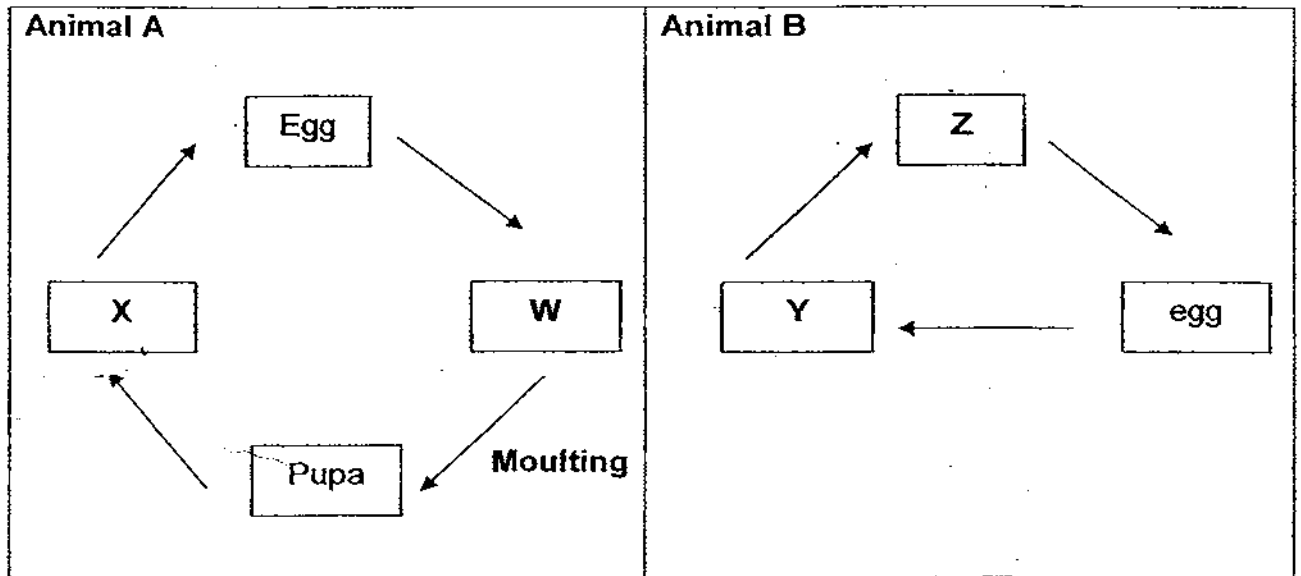

Which of the following best represents W, X, Y and Z in the two life cycles.

	W	X	Y	Z
①	nymph	cockroach	wiggler	mosquito
②	caterpillar	butterfly	nymph	grasshopper
③	wiggler	beetle	caterpillar	butterfly
④	maggot	mosquito	mealworm	beetle

12. Which of the animals below has the same life cycle as that of the animal shown in the picture?



- ① Beetle
- ② Mosquito
- ③ Housefly
- ④ Cockroach

13. Which of the following shows the correct sequence of the stages in a plant's life cycle?

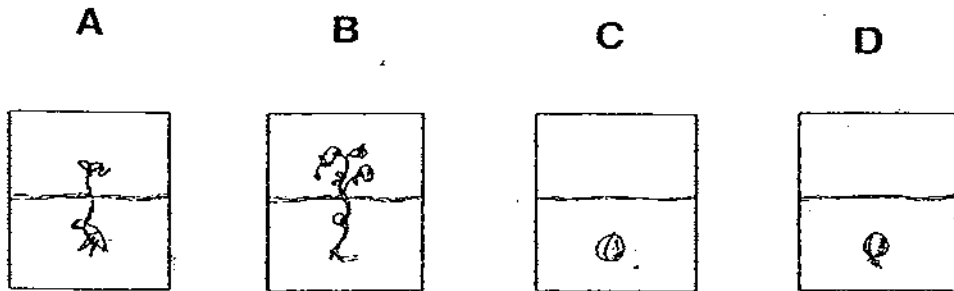

- (1) B → C → A → D
 (2) C → D → A → B
 (3) A → D → B → C
 (4) D → B → C → A

14. The picture below shows a lotus plant.

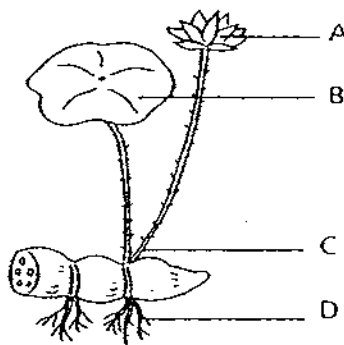

Which part(s) of the lotus plant labelled will ~~develop into the structure~~ that contains seeds?

- (1) A only
 (2) A and C only
 (3) B and D only
 (4) A, B and D only

15. Which one of the following diagrams shows the life cycle of a sunflower plant ~~correctly?~~

(1)

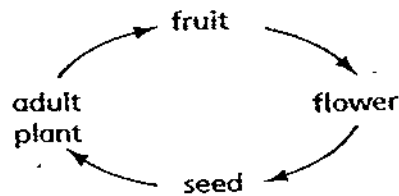

(2)

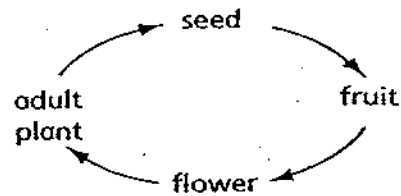

(3)

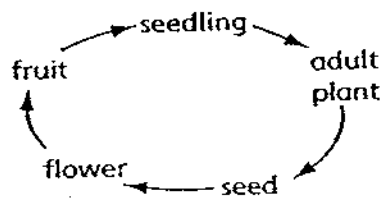

(4)

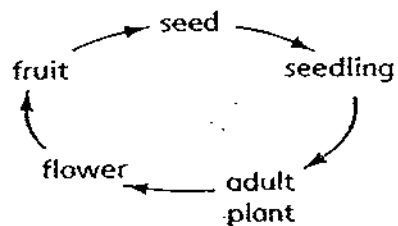

16. Brandon observed the following objects.



padlock



magazine



eraser



20-cent coin

He made the following inferences.

- A They ~~will~~ break into pieces when dropped.
- B They are made from things which were once alive.
- C They are made of different materials with different hardness.
- D The 20-cent coin can be used to scratch the eraser because the coin is harder than the eraser.

Which of the inferences that Brandon has made is/are correct?

- (1) B only
- (2) A and C only
- (3) C and D only
- (4) A, C and D only

17.

Group X	Group Y
A piece of drift wood	A glass vase
An empty plastic bag	A metal fork

The following objects are grouped according to whether they are _____.

- (1) flexible
- (2) waterproof
- (3) able to float in water
- (4) made of the same materials

18. Name the kind of material used to make the parts of the car labelled P, Q and R.

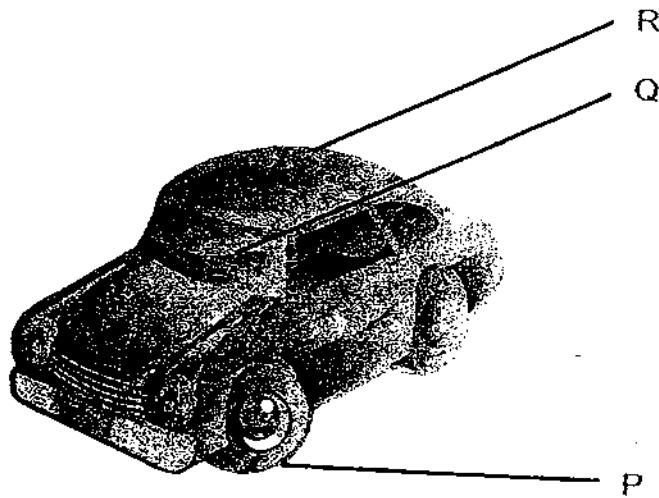

	P	Q	R
<input checked="" type="radio"/> (1)	wood	rubber	plastic
<input checked="" type="radio"/> (2)	rubber	glass	metal
<input checked="" type="radio"/> (3)	plastic	wood	glass
<input checked="" type="radio"/> (4)	ceramic	metal	wood

19. Study the table below.

	Material A	Material B	Material C	Material D
Able to float	Yes	No	Yes	No
Easy to wash	No	Yes	No	Yes
Able to keep warm	No	No	Yes	Yes
Light and waterproof	Yes	Yes	No	No

Mrs Govida is choosing a material to make a blanket for her grandson. Which material should she choose?

- (1) Material A
 (2) Material B
 (3) Material C
 (4) Material D
20. A group of students were having a discussion on magnets. Read their statements carefully.

Abel: ~~Materials~~ are magnets.

Ravi: ✓ Every magnet has two poles, no matter what shape it is

Mala: Like poles of two magnets attract, while unlike poles repel.

Lynn: The N-pole of the magnet is also known as the South-seeking pole.

Which of the statement/s above do you agree with?

- (1) Ravi only
 (2) Abel and Ravi only
 (3) Mala and Lynn only
 (4) Abel, Ravi and Mala only
21. What are the ways that you can destroy a magnet's magnetism?

- A. by heating it
 B. by soaking it in oil
 C. by dropping it repeatedly
 D. by hammering it many times

- (1) A and B only
 (2) C and D only
 (3) A, C and D only
 (4) A, B, C and D

22. The diagram below shows the arrangement of four bar magnets that forms a rectangular frame.

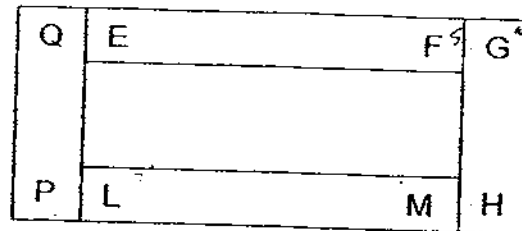

Which of the following arrangements are possible?

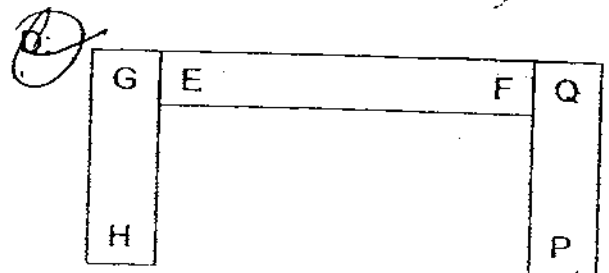
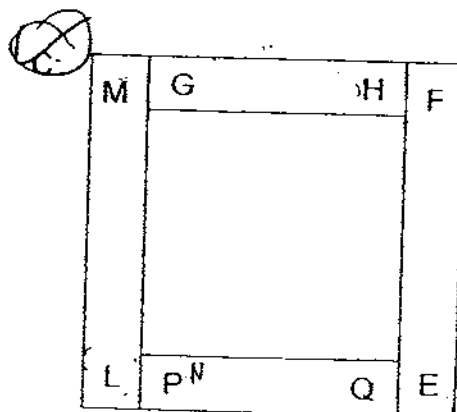
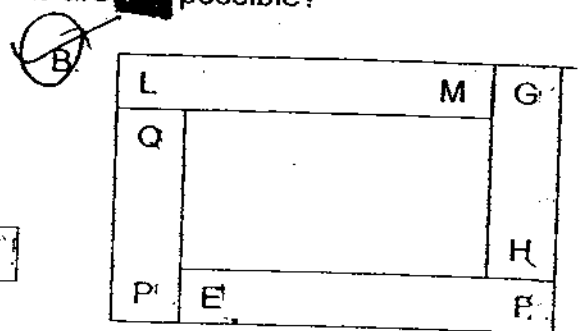
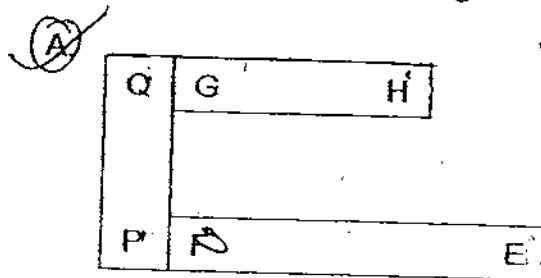

- (1) A and D only
 (2) B and C only
 (3) A, B and D only
 (4) B, C and D only

23. Which of the following objects make use of magnets in them to work?

- ~~A.~~ Door bell
~~B.~~ Credit card
~~C.~~ Telephone
~~D.~~ Refrigerator

- (1) B only
 (2) C and D only
 (3) A, B and C only
 (4) A, B, C and D

24. Study the diagrams below.

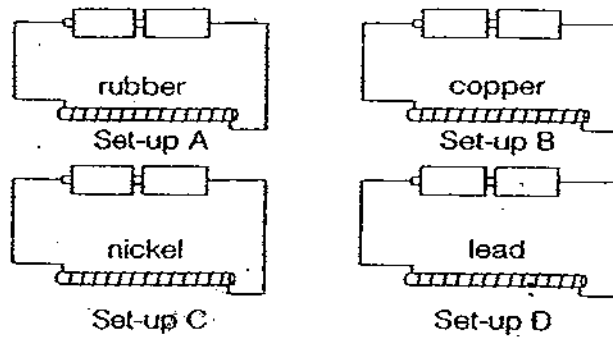

Which of the following set-ups will produce an electromagnet?

- (1) B only
- (2) C only
- (3) B & C only
- (4) B, C and D only

25. Two magnets were used to stroke the iron bar 80 times in the directions as shown by the arrows. The iron bar became magnetised as a result of the stroking.

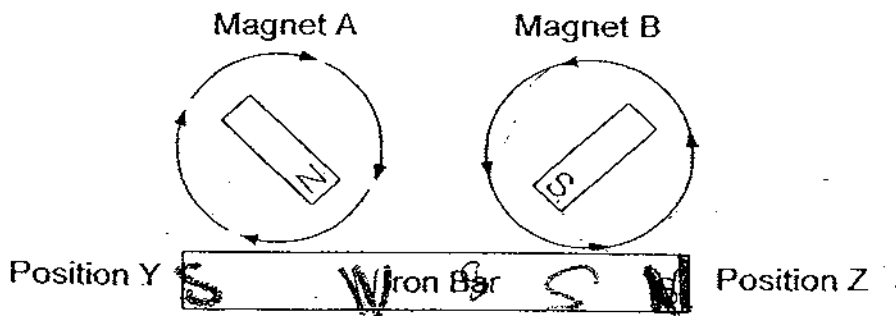

Which of the following options indicate correctly the poles of the newly magnetised iron bar?

	Y	Z
<input checked="" type="radio"/> (1)	North	North
<input checked="" type="radio"/> (2)	South	South
<input checked="" type="radio"/> (3)	North	South
<input checked="" type="radio"/> (4)	South	North

METHODIST GIRLS' SCHOOL (PRIMARY)
Founded in 1887



PRIMARY 3 END-OF-YEAR EXAMINATION 2009
SCIENCE
BOOKLET B

Total Time : 1 hour 45 minutes

INSTRUCTIONS TO CANDIDATES

Do not open the booklet until you are told to do so.
Follow all instructions carefully.
Answer all questions.

Name: _____ ()

Class: Primary 3. _____

Date: 12 October 2009

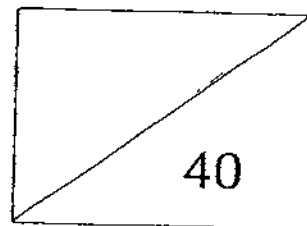

This booklet consists of 12 printed pages.

Section B : (40 marks)

Write the answers in the blanks provided.

26. Some pupils did a study on living and non-living things, X, Y and Z. They recorded the following observations as shown in the table below. (1mark)

Characteristics	X	Y	Z
Can move around	√	√	
Respond to changes around it	√	√	√
Need air, water and food	√		√
Can grow and reproduce	√		√
Wastes are produced from their bodies	√		

From the checklist above,

Letter _____ could be a hamster.

Letter _____ could be a toy robot.

27. Study the classification table below.

Living things			
Animals	Plants	Group Q	Group R
platypus	water lily	mould	bacteria
whale	hibiscus	toadstool	yeast

- (a) Give a suitable heading for Group Q and Group R. (1 mark)

Group Q: _____

Group R: _____

- (b) In which heading will you classify the Maiden's hair fern? (1mark)

28. The animals below are classified into two groups A and B.

Group A	Group B
<p data-bbox="501 421 719 495"><u>Mammals</u> Spiny anteater</p> <div data-bbox="513 506 716 577" style="border: 1px solid black; width: fit-content; margin: 0 auto; text-align: center; padding: 5px;">X</div> <p data-bbox="523 633 675 741"><u>Fish</u> Gold fish Angel fish</p> <p data-bbox="539 775 659 882"><u>Birds</u> Rooster Ostrich</p> <p data-bbox="512 916 675 1023"><u>Insects</u> Cockroach Moth</p>	<p data-bbox="1066 434 1222 542"><u>Mammals</u> Bat Panda</p> <p data-bbox="1098 611 1174 647"><u>Fish</u></p> <div data-bbox="1034 651 1238 723" style="border: 1px solid black; width: fit-content; margin: 0 auto; text-align: center; padding: 5px;">Y</div> <p data-bbox="1090 752 1174 788">Molly</p>

(a) Give a suitable **heading** for Group A and Group B to suggest how the animals are classified. (1 mark)

Group A: _____

Group B: _____

(b) What animals can be placed in box X and box Y? (1 mark)

X: _____

Y: _____

29. Study the flow chart below.

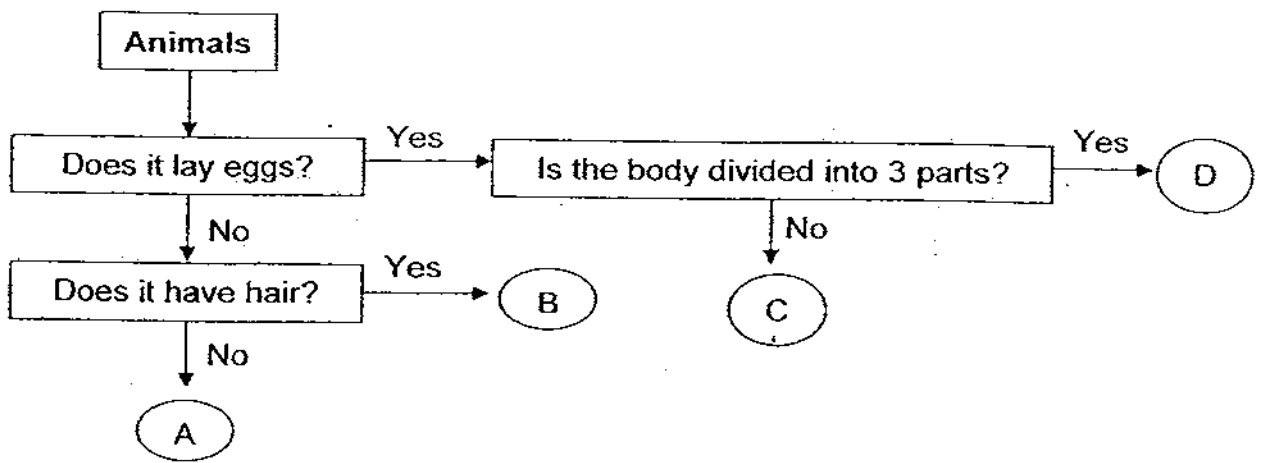

(a) Based on the flow chart, state 2 characteristics of Animal A. (1 mark)

- (i) _____
- (ii) _____

(b) Write the letter, A, B, C or D, which represents the following animals. (1 mark)

- (i) Cat : _____
- (ii) Ant : _____

(c) Lilin made the following statement:

“Animal C is a whale”

Explain why the statement made by Lilin is **incorrect**. (1 mark)

(d) An ostrich is classified under birds. Which group should a whale be classified under?

_____ (1 mark)

(e) Can a housefly be placed in Group C? Explain your answer. (1 mark)

30. Samantha cut open the papaya below and saw some black spots in the core of the fruit.

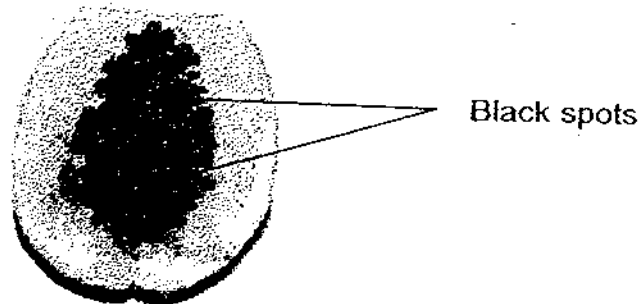

- (a) What are these 'black spots'? (1 mark)

- (b) Why are these 'black spots' important to the papaya plant? (1 mark)

31. Complete the classification chart below. (1 mark)

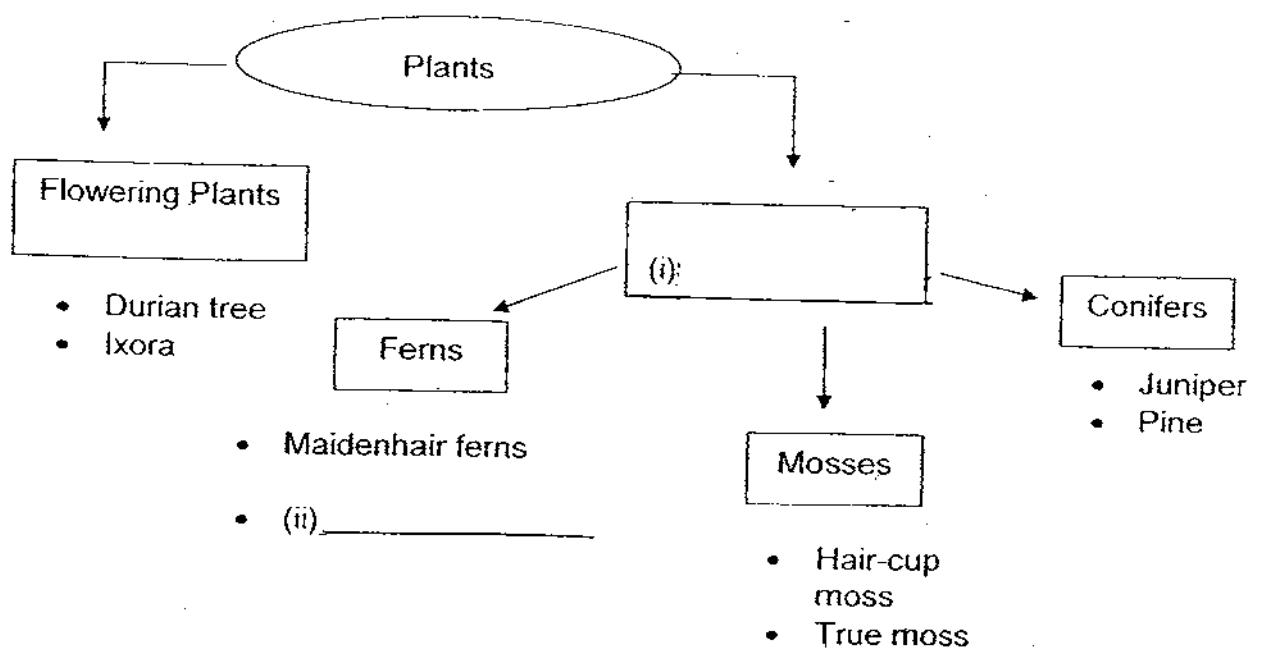



- (a) What is the name of the young of the mosquito as shown in the diagram above? (1 mark)
-
- (b) How many stages are there in the life cycle of a mosquito? (1 mark)
-
- (c) The young uses the breathing tube to breathe under the water. Suggest **one** way to stop the breeding of the mosquito. (1 mark)
-
- (d) Name **one** insect that has the same number of stages in its life cycle as a mosquito. (1 mark)
-
- (e) The graph below shows the number of Aedes mosquitoes over 6 months.

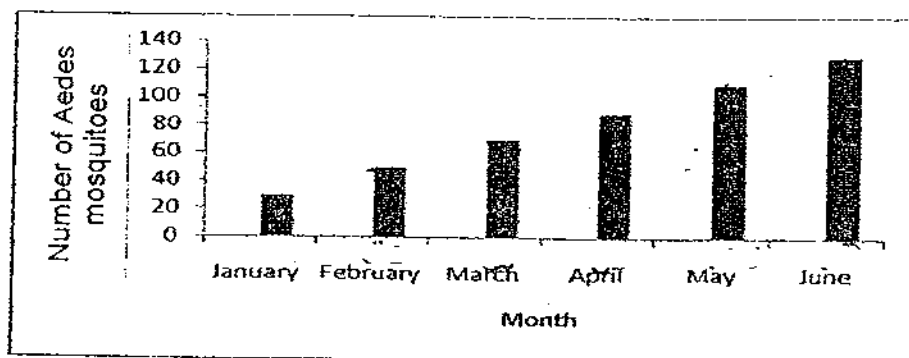

The graph shows that the number of mosquitoes increases over the months.

Name one characteristic of living things shown by the graph. (1 mark)

33. The diagram below shows two groups of living things. (Do not list the characteristics of living things).

Group A	Group B
fern ▲	mushroom ▲
grass	bread mould

- (a) Name one similar characteristic between a fern and a mushroom. (1 mark)

- (b) Name one difference between group A and group B. (1 mark)

34. Angeline would like to find out what conditions are required to grow green beans. She prepared four set-ups as shown below.

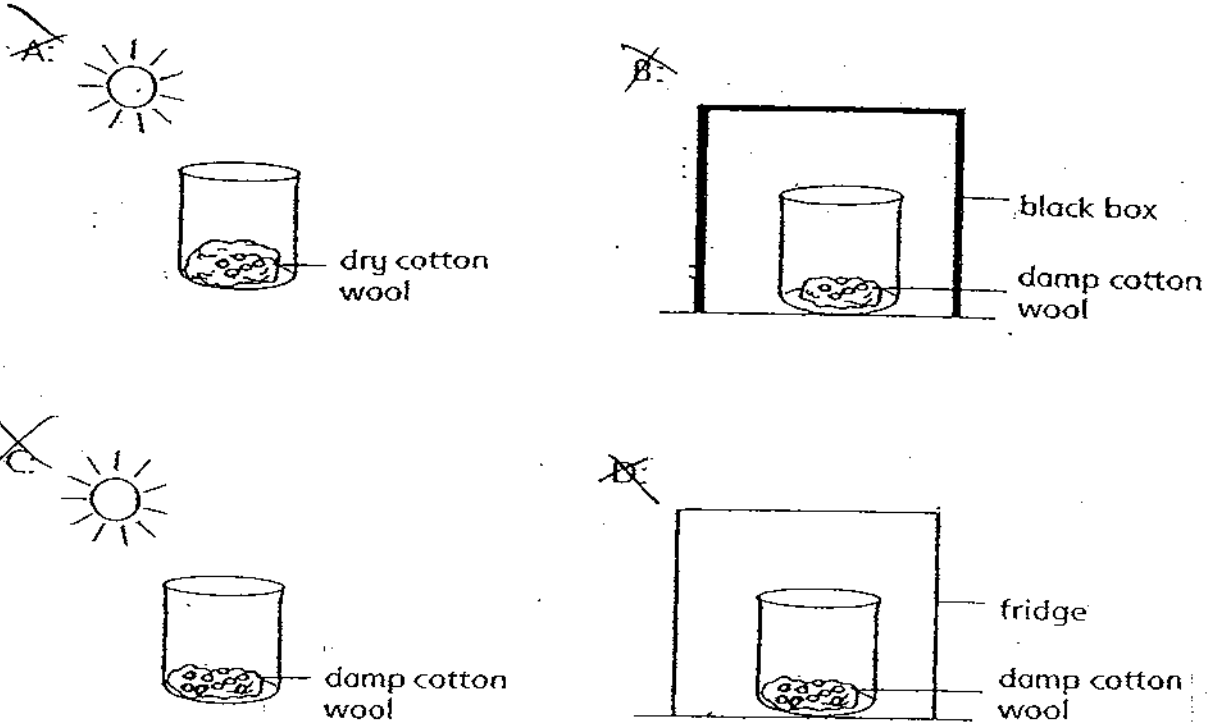

(a) In which of the two set-ups are the green beans most likely to grow? (1 mark)

(b) From Angeline's experiment, what are the three conditions necessary for green beans to grow into young plants? (2 marks)

(c) Jack noticed that Angeline's experiment was not conducted fairly. Do you agree with Jack? State 2 reasons why you agree or disagree with Jack. (2 marks)

35. Azman set up an experiment as shown below to find out which type of fabric can best absorb water.

He hanged four different types of fabric P, Q, R and S in a trough of water after dotting a specified length with water-soluble ink (Diagram I). As water was absorbed by the different types of fabric and travelled upwards, the dots of ink smudged (Diagram II).

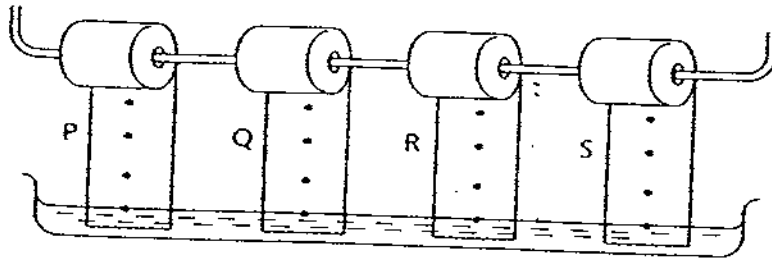

Diagram I

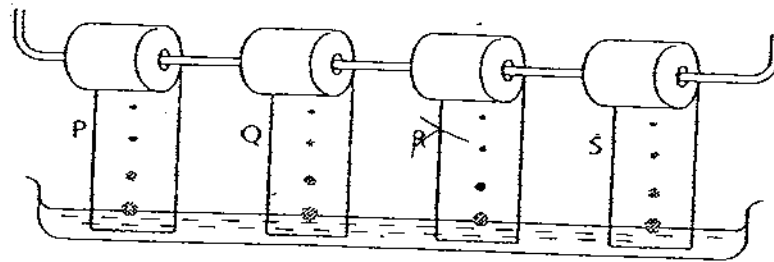
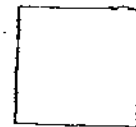
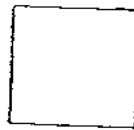
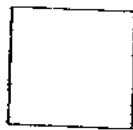

Diagram II

- (a) Arrange the four different types of fabric in order, beginning with the fabric that is least water absorbent. (1 mark)



Least Absorbent

Most Absorbent

- (b) Azman decided to hang another roll of fabric that is used to make raincoat and repeated the above experiment. Do you think the dots of ink will smudge? Explain your answer. (2 marks)

36. Seeva conducted an experiment to test the strength of four different materials used for making threads. These threads had the same length and thickness. Her observations were recorded and a graph was drawn as shown below.

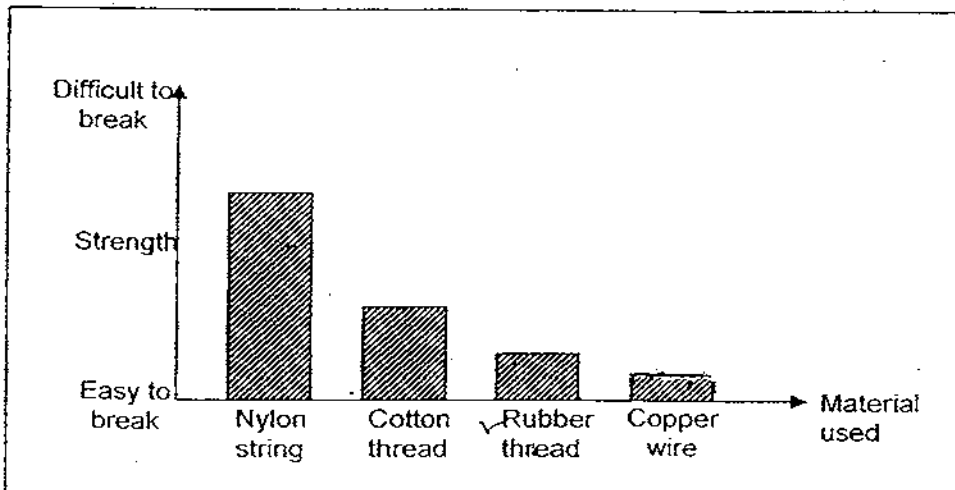
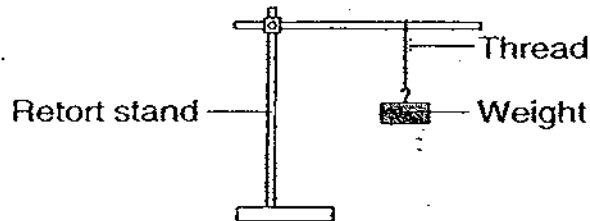

- (a) Complete the graph by **drawing** the bar for the copper wire in relation to the other materials. (1 mark)

- (b) Seeva was told to choose one of the four materials to make a fishing line. Which material would she choose? Explain your answer clearly by comparing the 4 materials. (2 marks)

37. The picture below shows 4 objects on the floor. Brenda uses a magnet to touch each of the objects. Help her classify the objects into two groups in the table below. (2 marks)

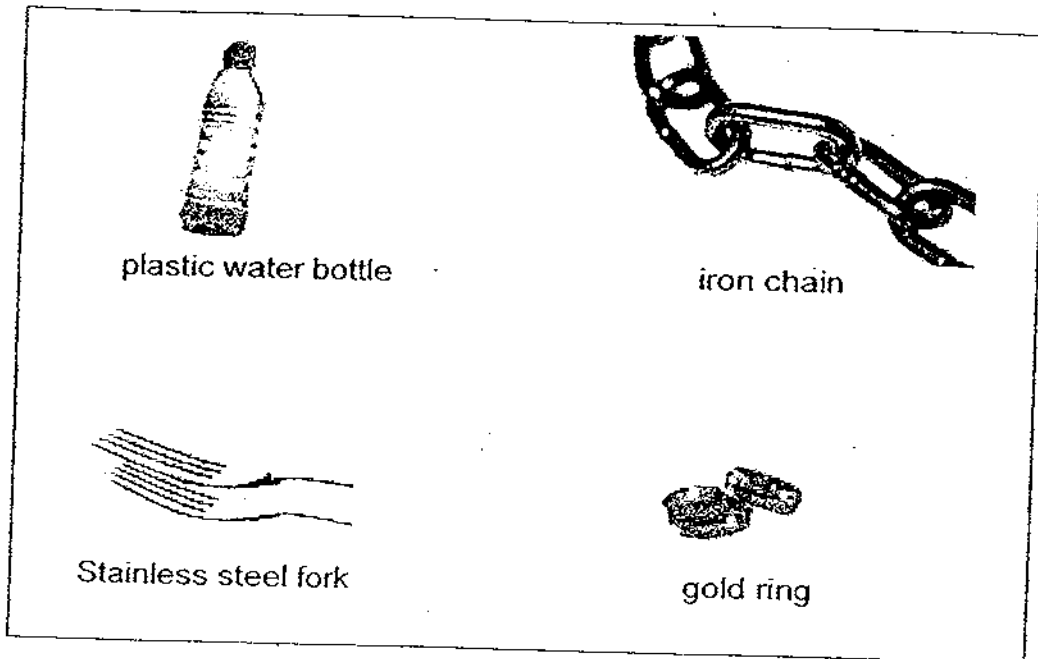

Magnetic	Non-magnetic

38. An electromagnet is made as shown below. State two ways in which it can be made stronger. (2 marks)

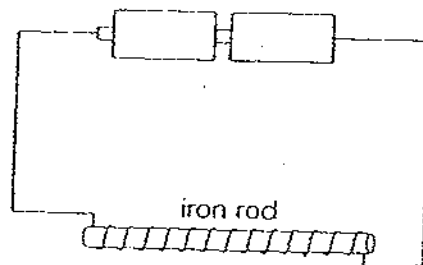

- (a) _____
- (b) _____

39. Nick carried out an experiment to test the strength of magnets as shown below. He put magnet W on the table and measured the furthest distance 'x' that the iron nail can be placed before magnet W can attract the iron nail.

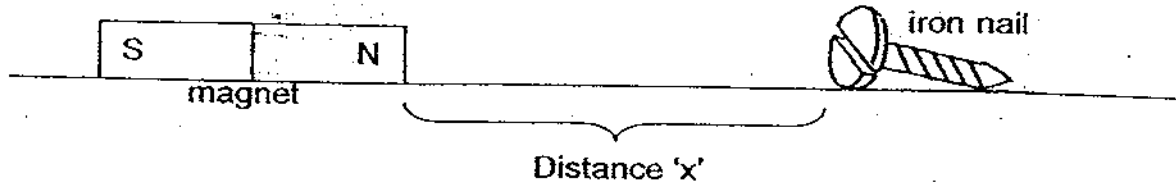

He repeated the experiment using magnets X, Y and Z and recorded the results in the table below.

Magnet	Distance 'x' (cm)
W	5
X	2
Y	6
Z	8

- (a) Which magnet is the strongest? (1 mark)

- (b) Name one variable that must be kept the same for the experiment to be considered a fair test. (1 mark)

- (c) What should Nick do so that his results will be more reliable? (1 mark)

40. The diagram below shows how a magnetic separator is used to get magnetic substances that are useful materials.

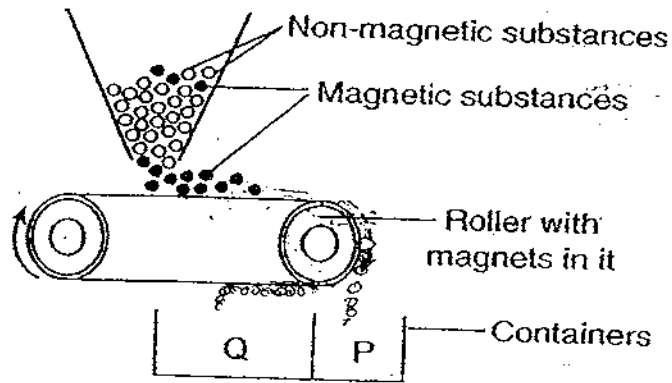

- (a) Write the letters, ^PA and ^QB, in the table below to show where the magnetic and non-magnetic materials will fall into. (1 mark)

Type of materials	Container
Magnetic	
Non-magnetic	

- (b) Explain your answer in (a). (1 mark)

End of paper.
Have you checked your work?

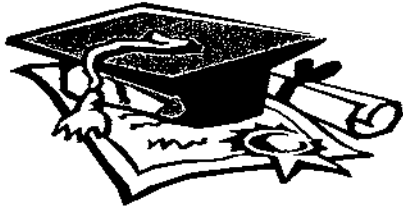

ANSWER SHEET

EXAM PAPER 2009

**SCHOOL : M G S PRIMARY
SUBJECT : PRIMARY 3 SCIENCE**

TERM : SA2

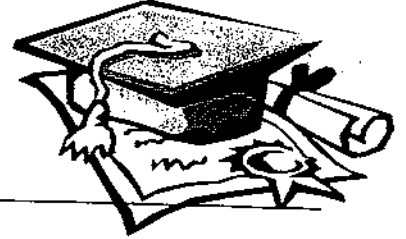

Q1	Q2	Q3	Q4	Q5	Q6	Q7	Q8	Q9	Q10	Q11	Q12	Q13	Q14	Q15	Q16	Q17
1	3	1	1	2	4	4	1	3	4	2	4	2	1	4	4	3

Q18	Q19	Q20	Q21	Q22	Q23	Q24	Q25
2	4	1	3	4	4	2	4

26)X, Y

27)a)Q: Fungi R: Micro-organism
b)Plants.

28)a)A: Lay eggs. B: Give birth to young alive.
b)X: Platypus. Y: Guppy.

29)a)i)Does not lay eggs. ii)Does not have hair.
b)i)B ii)D
c)A whale does not lay eggs.
d)Mammals.
e)No, a housefly has 3 body parts.

30)a)It is the seeds.
b)So that the papaya seeds can grow into a new papaya tree.

31)i)non-flowering plant. ii)Bird's nest ferns.

32)a)Wiggler b)4 stages c)Pour oil into the water. d)Housefly.
e)Living things reproduce.

33)a)Both reproduce by spores.
b)Group A is plants but Group B is fungi.

34)a) B and C.

b) The green beans need water, air, warmth to germinate.

c) Yes, the number of seeds used, are not the same.

Yes, the amount of cotton wool used is different.

35)a) R, P, Q, S

b) No. As the material to make the raincoat is waterproof and will not absorb water.

36)a)

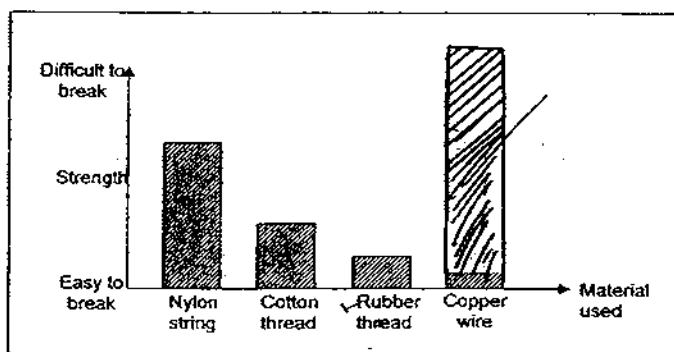

b) Nylon as it is flexible compare to copper. Nylon is also relatively strong. It will not break easily compared to cotton and rubber.

37) Magnetic: Stainless steel fork. Iron chain.

Non-magnetic: Gold ring. Plastic water bottle.

38)a) Increase the number of batteries.

b) Increase the number of coils round the Iron rod.

39)a) Magnet Z is the strongest.

b) Use the same iron nail.

c) Nick should do it 4 more times.

40)a) Q, P

b) The magnetic-substances will be attracted until it reaches container Q, whereas the non-magnetic substances will not be attracted the whole time and will fall into the container P.