



NAN HUA PRIMARY SCHOOL  
 END-OF-YEAR EXAMINATION 2023  
 PRIMARY 3

SCIENCE  
 (BOOKLET A)

Total Time for Booklets A and B: 1 hour 30 minutes

**INSTRUCTIONS TO CANDIDATES**

1. Write your name, index number and class in the spaces provided below.
2. Do not turn over the page until you are told to do so.
3. Follow all instructions carefully.
4. Answer all questions.
5. Use a 2B pencil to shade your answers on the Optical Answer Sheet (OAS).

**Marks Obtained**

Booklet A		/ 48
Booklet B		/ 32
Total		/ 80

Name: \_\_\_\_\_ (     )                      Class: P 3 \_\_\_\_\_

Date: 24 October 2023                      Parent's Signature: \_\_\_\_\_

---

This booklet consists of 20 printed pages.



For each question from 1 to 24, four options are given. One of them is the correct answer. Make your choice (1, 2, 3 or 4). Shade the correct oval (1, 2, 3 or 4) on the Optical Answer Sheet.

(48 marks)

- 1 Siti wants to keep a pet mouse.

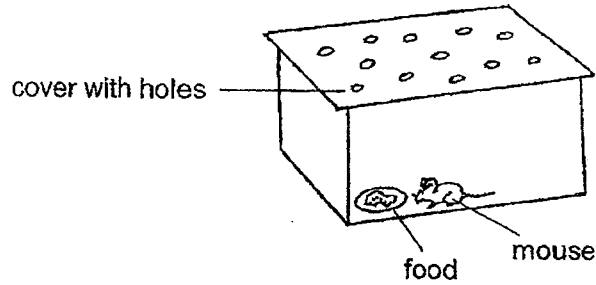

Based on the diagram above, what else must Siti provide so that the mouse can stay alive?

Siti needs to provide the mouse with \_\_\_\_\_.

- (1) air
  - (2) water
  - (3) food and water
  - (4) air, food and water
- 2 The diagrams below show how a caterpillar changes over time.

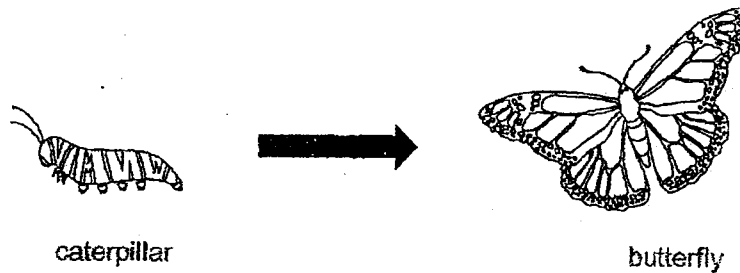

Which characteristic of living things is shown above?

- (1) Living things die.
- (2) Living things grow.
- (3) Living things reproduce.
- (4) Living things respond to changes around them.

3 Raju saw the following things at the park.

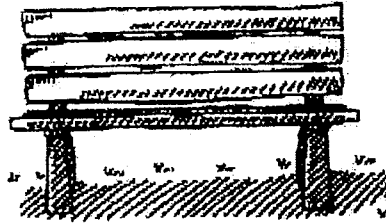

A

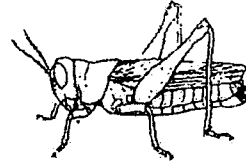

B



C



D

He classified them into two groups as shown in the table below.  
Which one of the following shows the correct classification of A, B, C and D?

	Living things	Non-living things
(1)	A and D	B and C
(2)	A and C	B and D
(3)	B and C	A and D
(4)	B and D	A and C

(Go on to the next page)

- 4 Some animals have been placed into groups E, F, G and H as shown in the classification chart below.

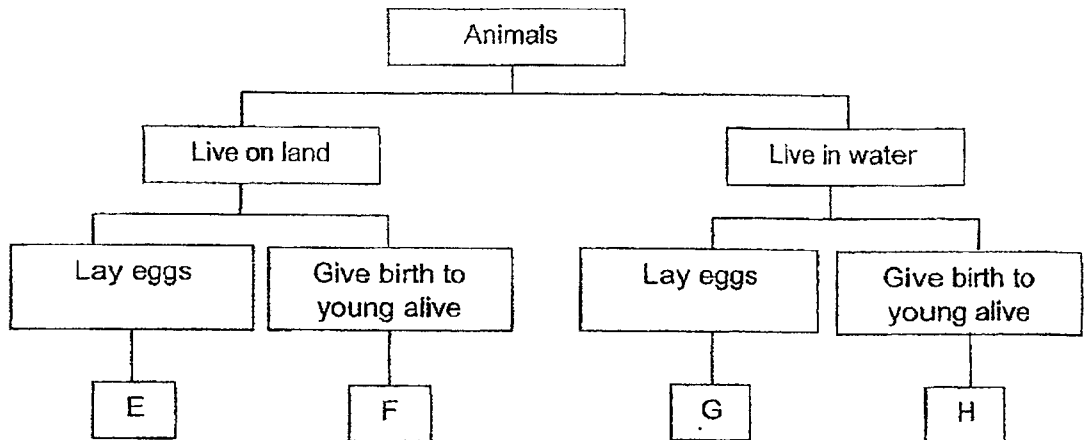

Peter was given a card with a description on animal X.

**Animal X**

- It has wings and can fly.
- It has hair as its outer covering.
- It can be found in cool, dark places like caves, trees or even buildings.

Based on the description above, in which group, E, F, G or H, should Peter classify animal X?

- (1) E
- (2) F
- (3) G
- (4) H

- 5 Study the two living things in the pictures below.



mushroom

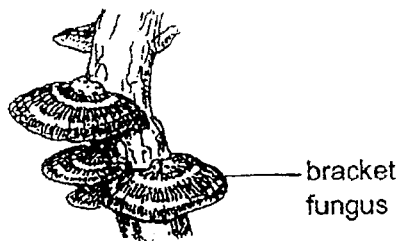

Which of the following statements about the two living things above are correct?

- A Both are always harmful.
- B Both reproduce by spores.
- C Both can make their own food.
- D Both break down things into simpler substances.

- (1) A and C only
- (2) B and D only
- (3) A, B and D only
- (4) B, C and D only

- 6 The following are some descriptions of living things Q, R and S.

- Q can grow on dead plants and animals.
- R can only be seen with the help of a microscope.
- S is used in baking bread to make the dough rise.

Which of the following could Q, R and S be?

	Q	R	S
(1)	yeast	bacteria	bread mould
(2)	bacteria	mushroom	yeast
(3)	mushroom	yeast	bread mould
(4)	mushroom	bacteria	yeast

(Go on to the next page)

- 7 The table below lists the characteristics of three animals.

Animals	A	B	C
It has wings.	✓		✓
It has feathers.			✓
It has three body parts.	✓		
It feeds its young with milk.		✓	

Which of the following best represents animals A, B and C?

	A	B	C
(1)	parrot	cat	cockroach
(2)	mosquito	ostrich	goldfish
(3)	grasshopper	beetle	snake
(4)	butterfly	cat	penguin

- 8 The diagram below shows the life cycle of animal M.

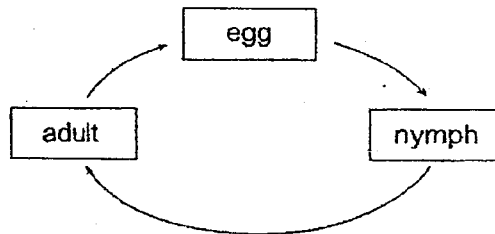

Based on the diagram above, which of the following statements about animal M is/are correct?

- A Animal M has 3 stages in its life cycle.
  - B Animal M gives birth to its young alive.
  - C At the nymph stage, animal M does not feed.
  - D Egg is the first stage of the life cycle of animal M.
- (1) A only  
 (2) A and C only  
 (3) B and D only  
 (4) A, C and D only

- 9 Study the pictures below.



Frogs and salamanders are able to live both on land and in water.  
On land, they breathe through their lungs.  
In water, they breathe through their \_\_\_\_\_.

- (1) gills
  - (2) spores
  - (3) moist skin
  - (4) holes in their bodies
- 10 The diagram below shows the life cycle of a butterfly. B represents the adult stage of the butterfly.

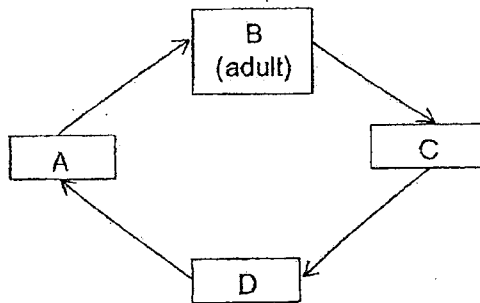

Four students each made a statement about the butterfly at the various stages.

- Lily At stage A, it does not eat and does not move from place to place.  
 Suzy At stage B, it cannot move around.  
 Yusof At stage C, it moults several times as it grows.  
 Jason At stage D, it spends most of its time eating.

Which of the students made the correct statement?

- (1) Lily and Jason only
- (2) Lily and Yusof only
- (3) Suzy and Yusof only
- (4) Suzy and Jason only

(Go on to the next page)



11 The diagram below shows the growth of a young plant with two missing stages P and Q.

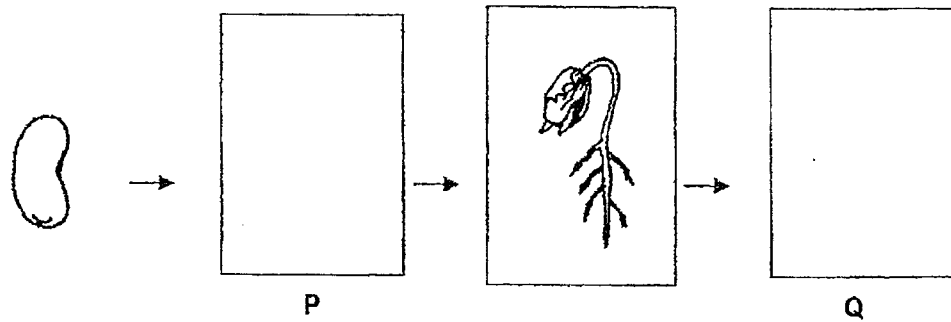

Which one of the following shows the correct stages for P and Q?

	P	Q
(1)		
(2)		
(3)		
(4)		

12 Study the flowchart below.

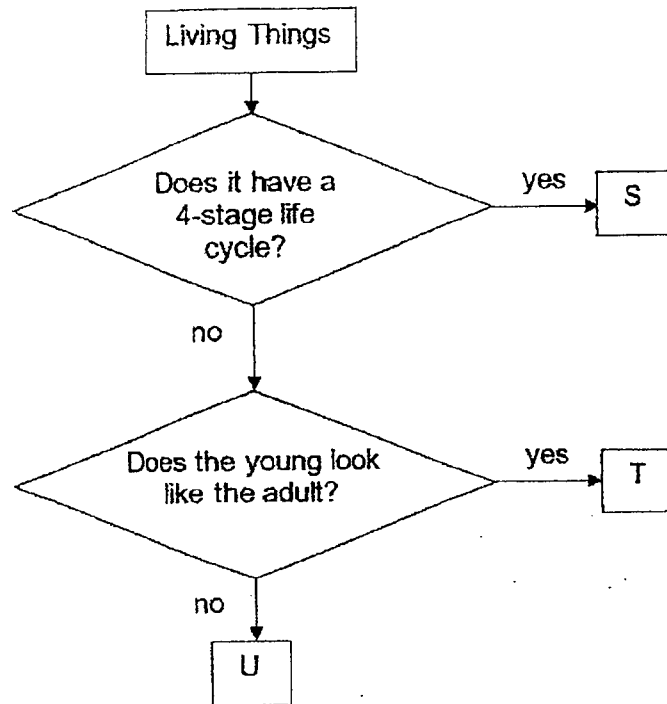

Which of the following correctly represents S, T and U?

	S	T	U
(1)	frog	chicken	cockroach
(2)	beetle	frog	mosquito
(3)	butterfly	cockroach	frog
(4)	mosquito	beetle	chicken

(Go on to the next page)

- 13 The diagram below shows Kumar sitting on a wooden chair and the chair did not break.

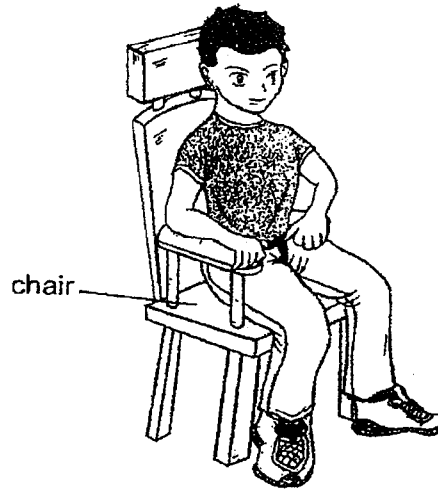

Wood is used to build the chair because wood \_\_\_\_\_.

- (1) is strong
  - (2) is waterproof
  - (3) can float on water
  - (4) does not allow light to pass through
- 14 Which of the following materials come from plants?

- (1) clay
- (2) wool
- (3) cotton
- (4) metal

- 15 Peter puts on a pair of toy glasses.

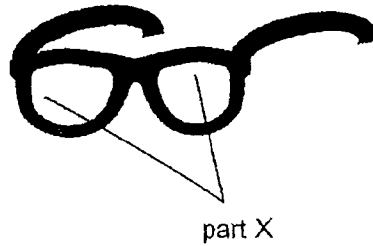

What is the property of the material used to make part X so that Peter can still see the words?

- (1) Strength
- (2) Flexibility
- (3) Waterproof
- (4) Transparency

(Go on to the next page)

- 16 Jeremiah conducted an experiment to find out which material, P, Q, R or S, is most suitable for making a raincoat as shown in the diagram below.



He soaked each of the four materials, P, Q, R and S, of the same size into four identical beakers containing 150 ml of water each.

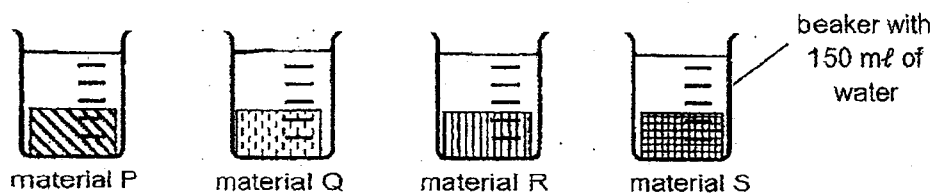

After two minutes, he removed the materials and recorded the amount of water left in each beaker as shown in the table.

Material	Amount of water left in the container (ml)
P	150
Q	123
R	95
S	0

Based on the results in the table, which material is most suitable for making a raincoat?

- (1) P
- (2) Q
- (3) R
- (4) S

- 17 Klinsmann placed three solids into a container of water. These solids are of the same size but are made of three different materials, A, B and C. His observation is shown below.

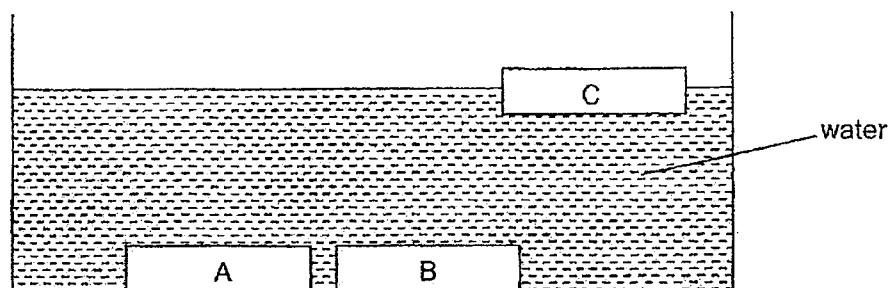

Three of his friends explained his observation.

- Ali      Only material C is able to sink in water,  
Beth     All of the materials do not float in water.  
Charles   Both material A and material B sink in water.

Which of the student(s) is/are correct?

- (1) Ali only  
(2) Charles only  
(3) Ali and Charles only  
(4) Ali, Beth and Charles

(Go on to the next page)

18 Study the flowchart below.

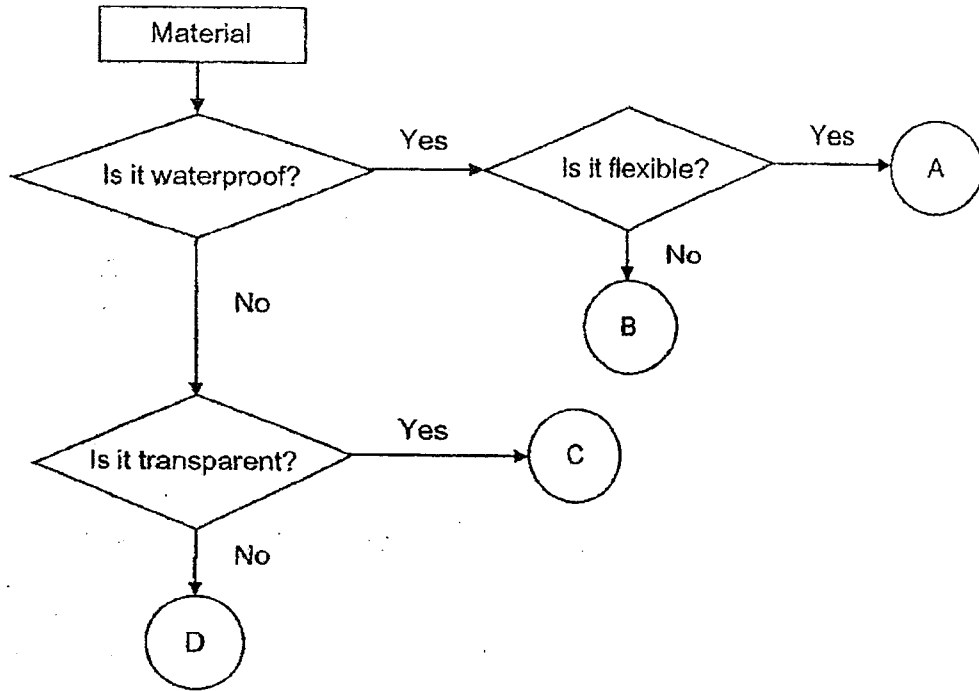

Based on the flowchart above, which material, A, B, C or D, is suitable for making part T of the outdoor tent as shown above.

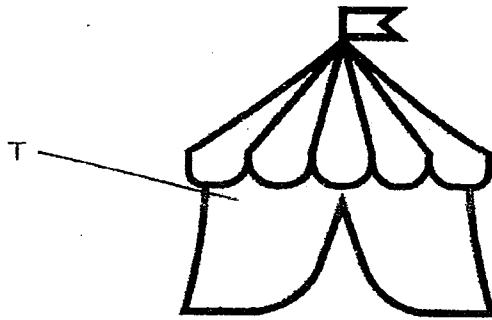

- (1) A
- (2) B
- (3) C
- (4) D

- 19 Two bar magnets AB and CD can be arranged as shown below. He placed a compass near D and the direction of the needle reacts as shown below.

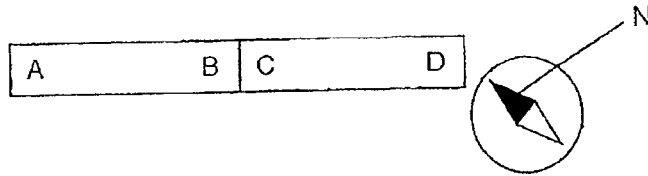

Which of the following arrangements of the magnets is **not** possible?

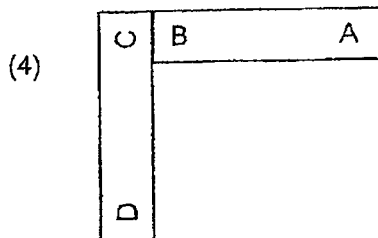
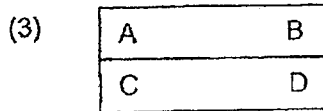
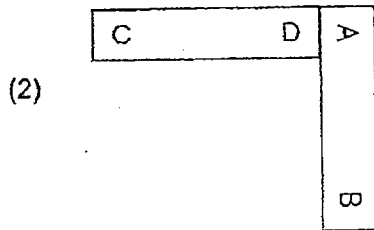
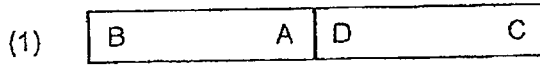

(Go on to the next page)



- 20 Mary carried out an investigation using three rectangular objects, PQ, RS and TU. She hung each object with a string and brought their ends close to each other. The diagrams below showed her observations.

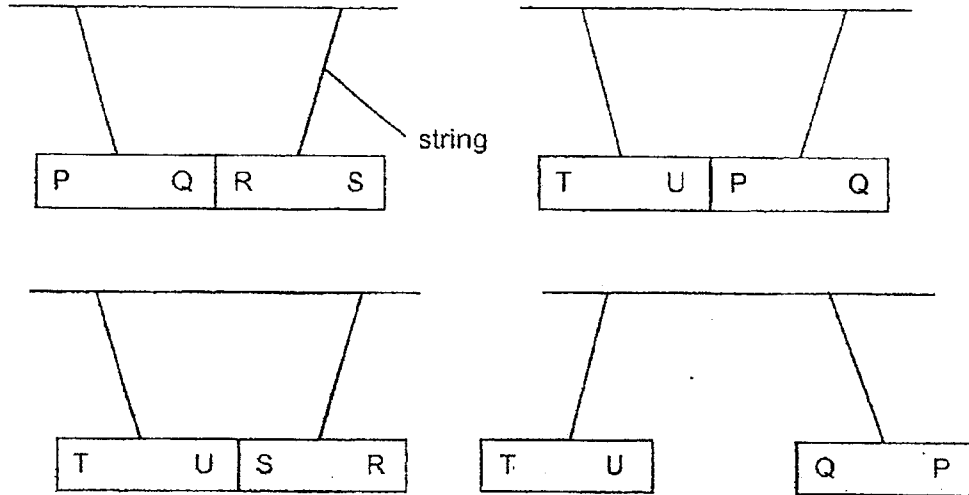

Which of the following about the objects are correct?

	PQ	RS	TU
(1)	magnet	plastic bar	steel bar
(2)	magnet	steel bar	plastic
(3)	magnet	steel bar	magnet
(4)	steel bar	magnet	magnet

21 Study the diagrams below.

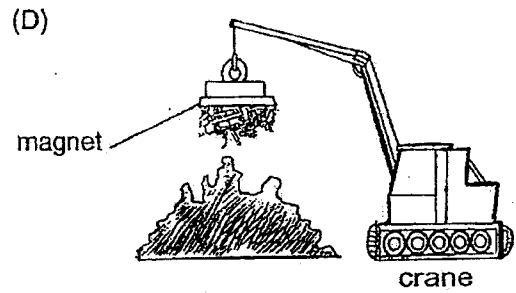
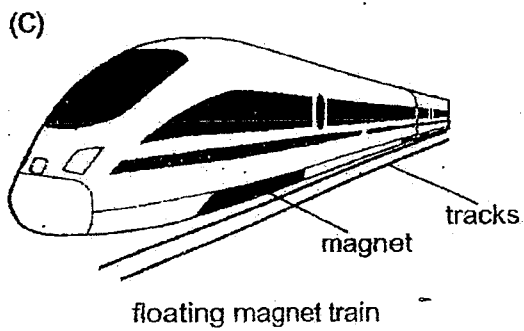
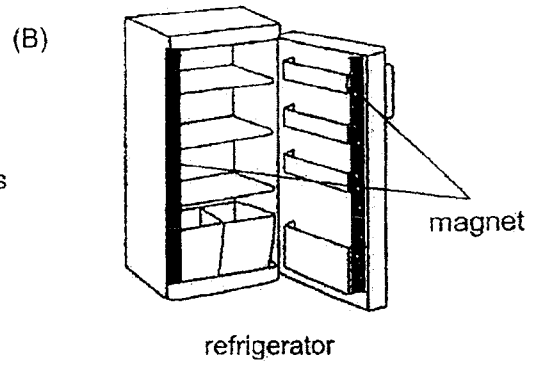
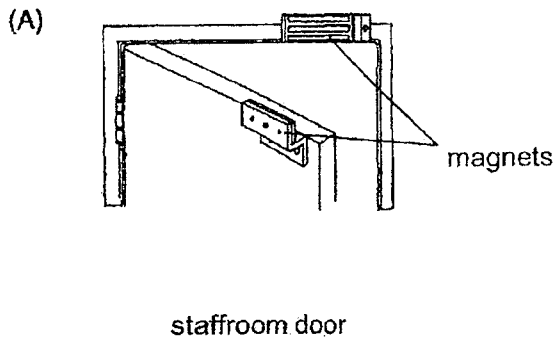

Which of the following shows an example of repelling magnets?

- (1) A only
- (2) C only
- (3) A, B and D only
- (4) All of the above

(Go on to the next page)

- 22 Alicia placed a magnet at equal distance from two rods, J and K, as shown below.

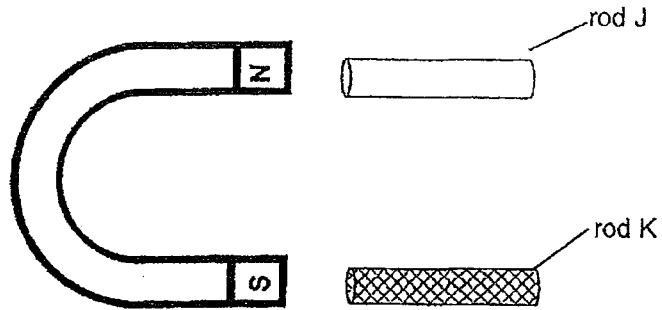

She observed the movement of both rod J and K and recorded them in the table below.

Rod	Direction of movement of the rod
J	towards the magnet
K	no movement

Based on Alicia's observation, which of the following statement(s) is/are correct?

- A Rod J can be a magnet or a magnetic material.
- B Rod J is made of a non-magnetic material.
- C Rod K is a magnet.

- (1) A only
- (2) A and B only
- (3) B and C only
- (4) None of the above

- 23 A steel bar AB was magnetised using the stroke method for 30 times as shown in diagram 1 below. Diagram 2 shows the magnetic poles of A and B after being magnetised.

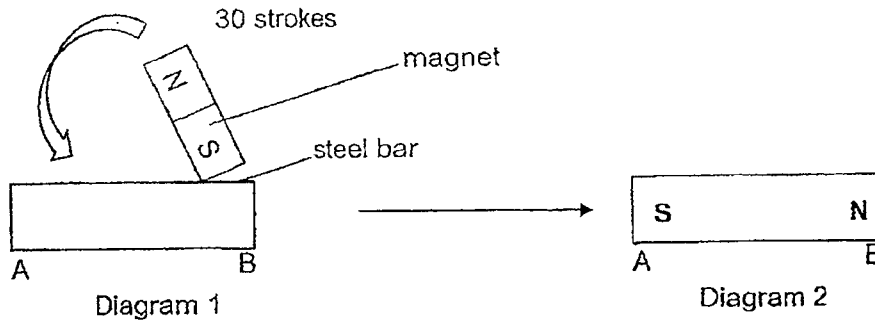

Another steel bar, CD, was magnetised with 50 strokes as shown in diagram 3.

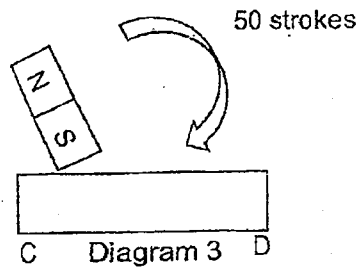

Which of the following is correct?

	Magnetic poles	Magnetic strength of steel bar CD
(1)		weaker
(2)		weaker
(3)		stronger
(4)		stronger

(Go on to the next page)

- 24 Terra conducted an experiment to find out how many steel nails were attracted to different parts of a magnet. She labelled four parts of a bar magnet E, F, G and H.

The graph below shows her findings.

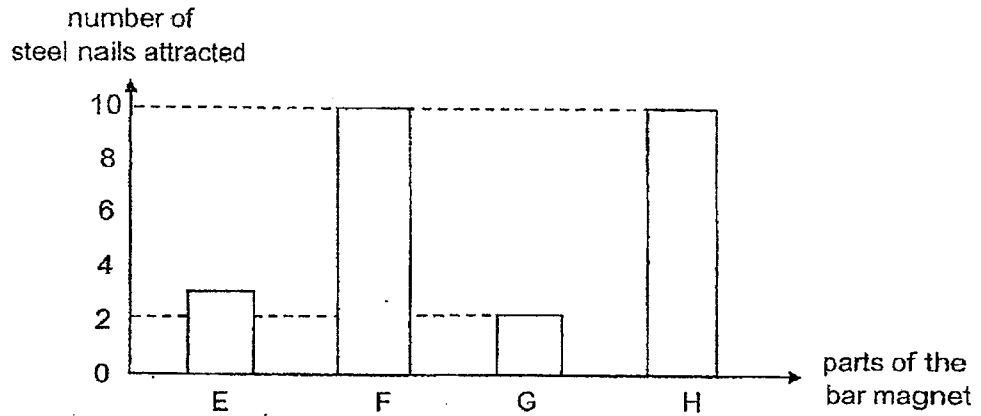

Which of the followings is most likely to be correct?

	Two poles of magnet		Centre of the bar magnet	
(1)	E	F	G	H
(2)	E	G	H	F
(3)	F	G	E	H
(4)	F	H	E	G

(Go on to booklet B)



NAN HUA PRIMARY SCHOOL  
END-OF-YEAR EXAMINATION 2023  
PRIMARY 3

SCIENCE  
(BOOKLET B)

Total Time for Booklets A and B: 1 hour 30 minutes

**INSTRUCTIONS TO CANDIDATES**

1. Write your name, index number and class in the spaces provided below.
2. Do not turn over the page until you are told to do so.
3. Follow all instructions carefully.
4. Answer all questions.
5. Use a pencil to write your answers in the space provided for each question.

**Marks Obtained**

Section B

	/ 32
--	------

Name: \_\_\_\_\_ ( )

Class: P 3

Date: 24 October 2023

Parent's Signature: \_\_\_\_\_

---

This booklet consists of 15 printed pages and 1 blank page.

For questions 25 to 34, write your answers in this booklet.

The number of marks allocated is shown in brackets [ ] at the end of each question or part question. (32 marks)

25 Animals A, B, C and D have been classified in the flowchart as shown below.

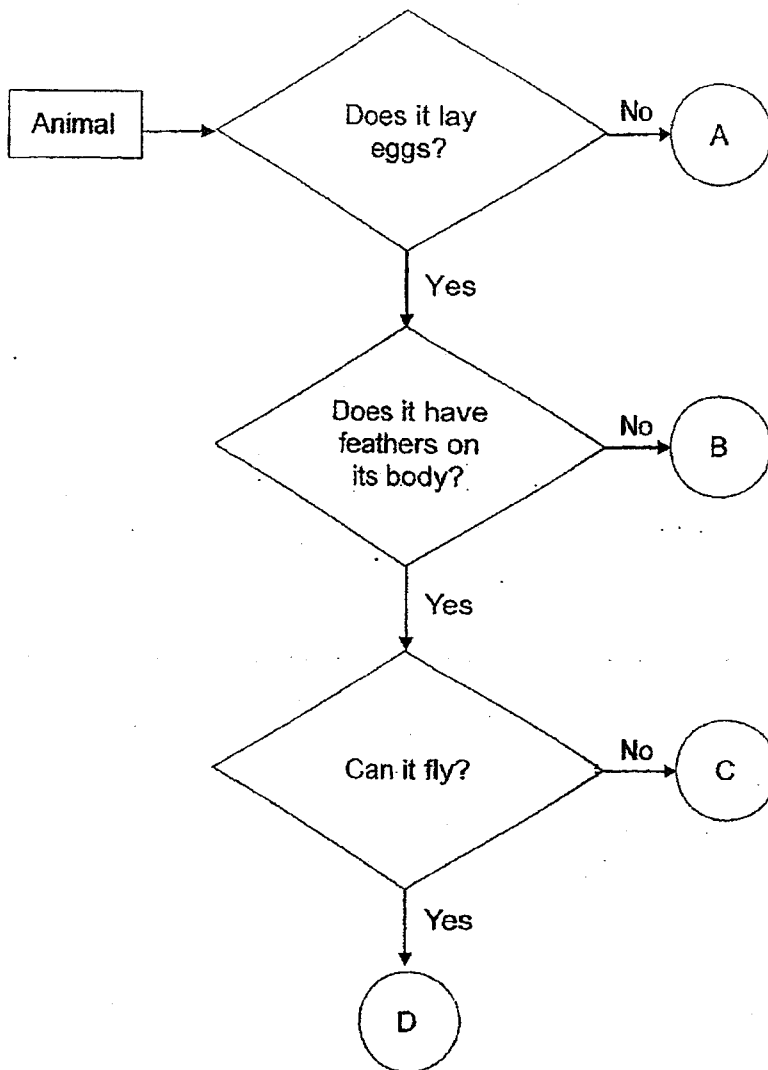

(a) Which animal(s), A, B, C or D, has/have feathers as outer covering? [1]

---

(b) Based on the flowchart above, describe **all** the characteristics of animal B. [1]

---

---

(c) Based on the flowchart above, state a difference between animal A and animal C. [1]

---

---

(d) Look at the picture of the animal below carefully.

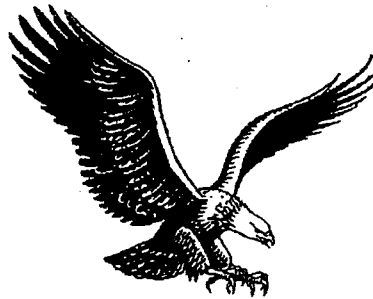

Which animal, A, B, C or D, most likely represents the animal in the picture above? [1]

---

Score	4
-------	---

(Go on to the next page)



26 Study the classification chart below.

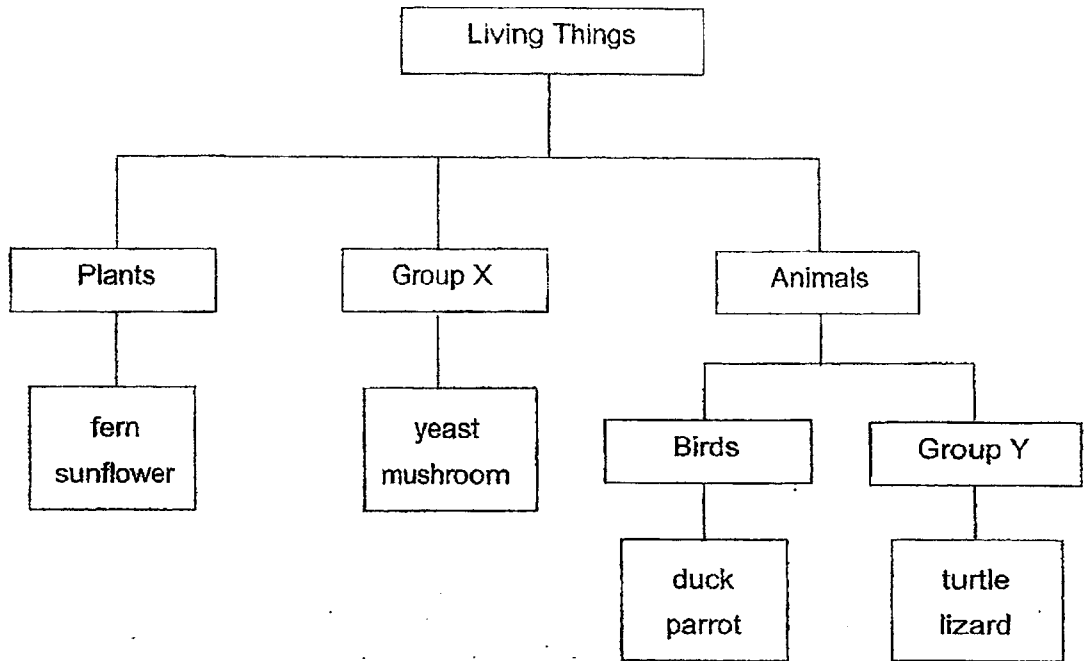

(a) Write down a suitable heading for Group X and Y. [2]

Group X: \_\_\_\_\_



Group Y: \_\_\_\_\_

(b) Name the animal group that has a different method of reproduction from the animals in Group Y. [1]

\_\_\_\_\_

Score	3
-------	---

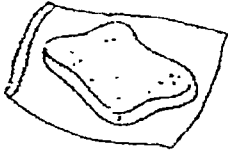
- 27 David puts three identical slices of bread in three sealed plastic bags as shown below.

		
<b>Set-up A</b> Bread placed on the table	<b>Set-up B</b> Toasted bread placed in the refrigerator	<b>Set-up C</b> Bread sprinkled with 5 drops of water and placed on the table

- (a) Which two set-ups should David use if he wants to find out if water is needed for bread mould to grow? [1]

---

- (b) In which set-up above would he first see bread mould growing? [1]

---

- (c) Explain your answer for (b). [1]

---

Score	3
-------	---

(Go on to the next page)

- 28 The diagram below shows the stages in the life cycle of a cockroach and a mealworm beetle.

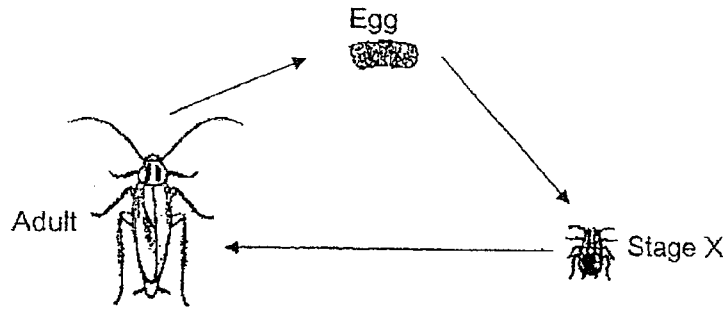

Life cycle of a cockroach

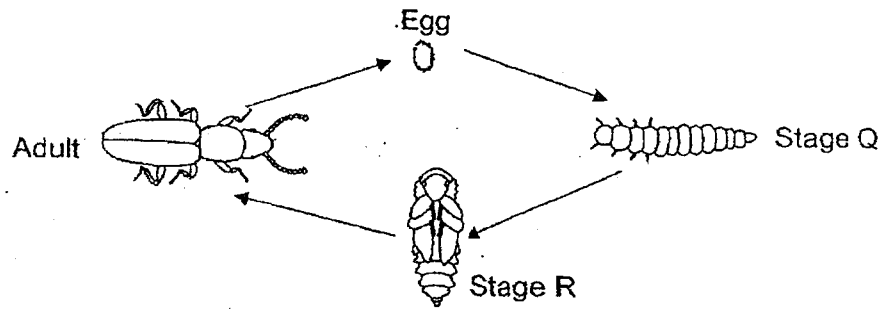

Life cycle of a mealworm beetle

- (a) State one difference between the life cycles of a cockroach and a mealworm beetle. [1]

---



---

- (b) State one difference between stage R and X. [1]

---



---

(c) The diagram below shows stages in the life cycle of a chicken.

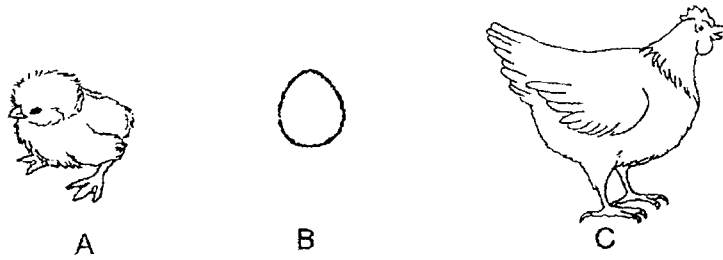

Arrange the stages in order by filling in the boxes with the correct letters. [1]

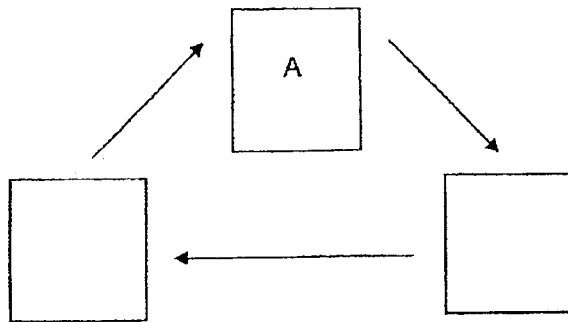

life cycle of a chicken

Score	3
-------	---

(Go on to the next page)

- 29 Emily observed the growth of plant Q from a seed. Below are the descriptions, A to D, she noted down in her Science journal.

Description A	The roots start to grow.
Description B	The shoot appears.
Description C	When the first leaf unfolds, the plant starts making its own food.
Description D	Flowers appear and they slowly develop into fruits.

- (a) Which above description shows that plant Q has become an adult plant? [1]

Description

Emily observed plant Q over 4 weeks. She measured and recorded its height as shown below.

Number of weeks	Height of plant (cm)
1	5
2	7
3	11
4	15

- (b) Based on the table above, what is the relationship between the number of weeks and the height of the plant? [1]

As the number of weeks increases, \_\_\_\_\_

---

Emily also wanted to find out if the amount of soil used would affect the growth of a plant. She carried out an experiment based on the set-ups shown below.

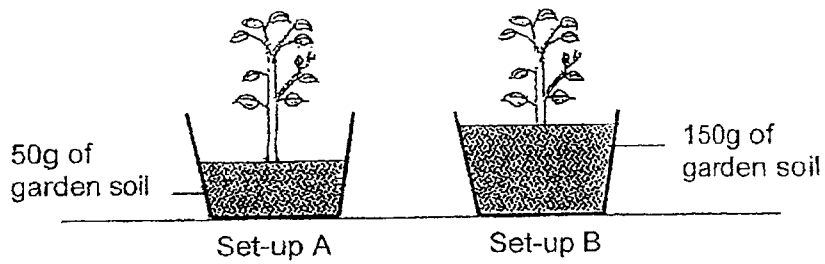

(c) What is the variable to be changed in this experiment?

[1]

---

---

Score	3
-------	---

(Go on to the next page)

30 The table below shows the properties of three materials, X, Y and Z.

Material	Property	
	Allow light to pass through	Flexibility
X	✓	
Y	✓	✓
Z		✓

Key  
 ✓ : yes

(a) Based on the information given in the table above, state the properties of material Z. [1]

---



---

(b) Yazid conducted an experiment using the set-up below. He wanted to find out which material, X, Y or Z, is most suitable to make a food tray.

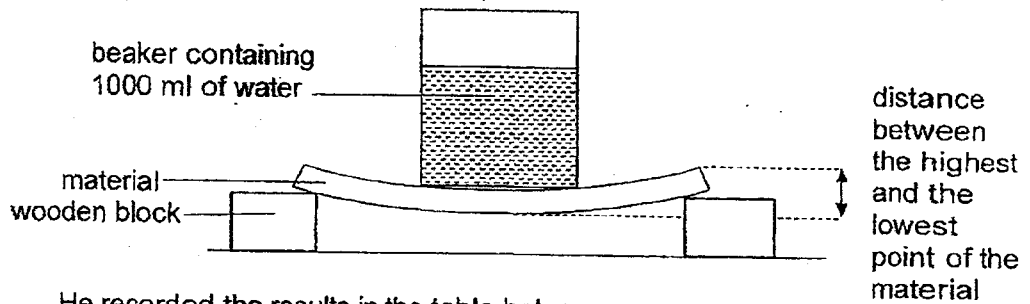

He recorded the results in the table below.

Material	Distance between the highest and the lowest point of the material (cm)
X	1
Y	4
Z	3

Based on the information in the table, which material, X, Y or Z, is most suitable for making a food tray? Explain your answer. [2]

---



---



---

- (c) State one variable he should keep constant to ensure the experiment is a fair test. [1]

Score	4
-------	---

31 Halimah grouped some items as shown below.

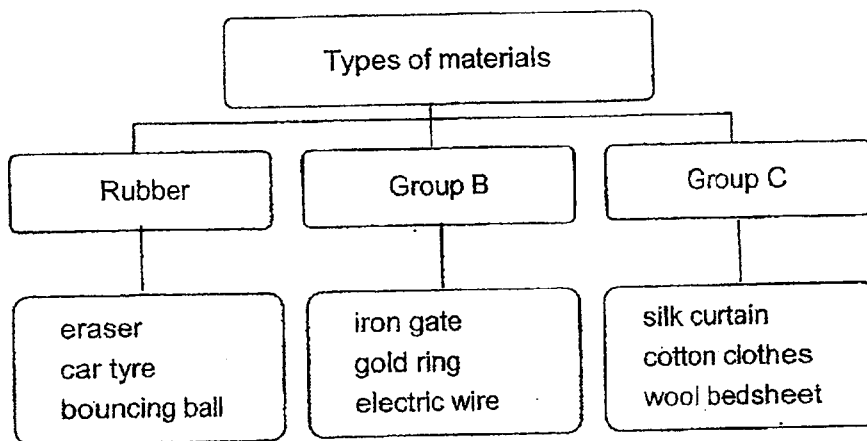

- (a) In which group, B or C, should a towel be correctly placed in? [1]

Group \_\_\_\_\_

- (b) Choose the possible headings for group B and group C. [1]

Metal	Fabric	Wood
-------	--------	------

Group B: \_\_\_\_\_

Group C: \_\_\_\_\_

Score	2
-------	---

(Go on to the next page)



- 32 Josh used the set-up below to test a certain property of fabrics, P, Q and R. They are of the same size and thickness but made of different materials. He placed some weights, one at a time, onto the fabric P until it tore.

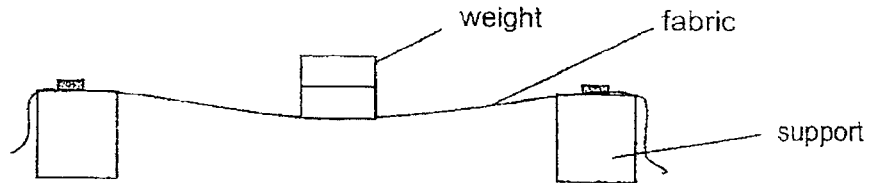

He repeated his test with fabric Q and R and recorded the results in the table below.

Fabric	Number of weights placed on the fabric before it tore
P	5
Q	3
R	6

- (a) What property of the fabric was Josh testing? [1]

---

The diagram below shows a school bag used for carrying books.

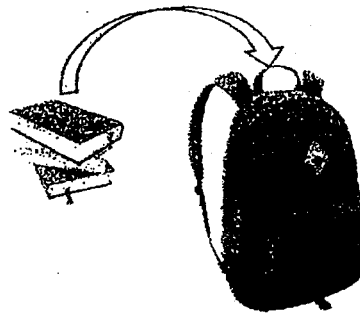

- (b) Based on Josh's experiment, which material, P, Q or R, is the most suitable to make the school bag? Explain your answer. [2]

---



---



---

Score	3
-------	---

33 Serena set up an experiment as shown in the diagram below.

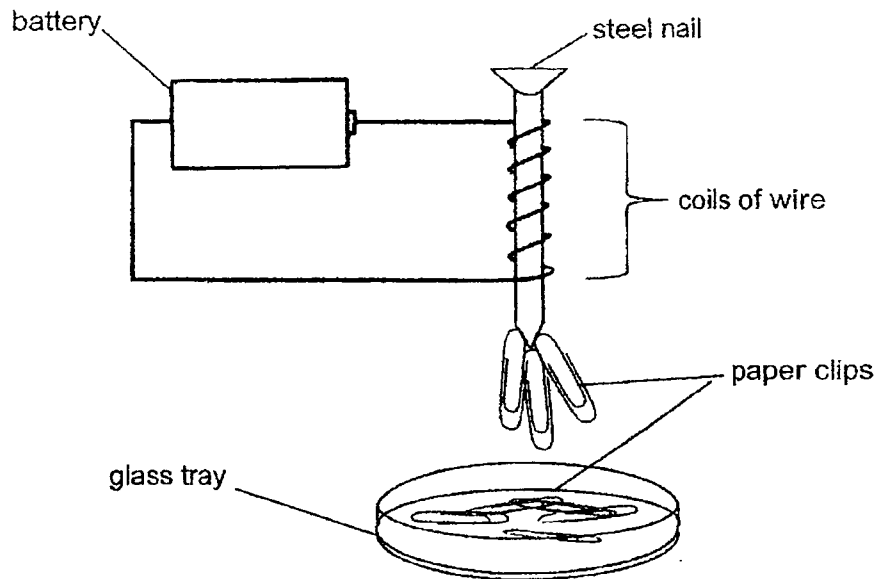

(a) Beside steel, name another suitable material that can be used to make the nail. [1]

\_\_\_\_\_

\_\_\_\_\_

(b) Suggest two ways to increase the number of paper clips attracted by the steel nail. [2]

(i) \_\_\_\_\_

(ii) \_\_\_\_\_

Score	3
-------	---

(Go on to the next page)

- 34 Three magnets, A, B and C, are hanging from strings of the same length. A glass tray of steel paper clips is placed below the magnets. All the magnets are lowered and they attracted a number of steel paper clips as shown below.

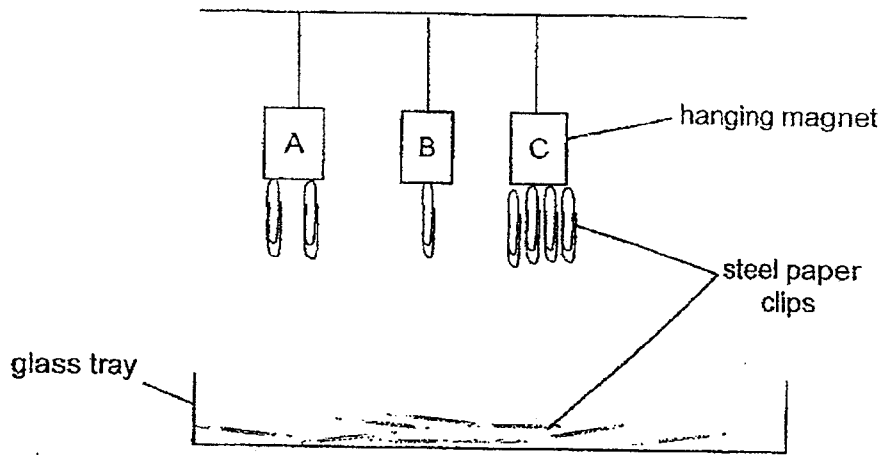

- (a) Based on the diagram above, arrange the magnets, A, B and C, according to their magnetic strength in the boxes provided below. [1]

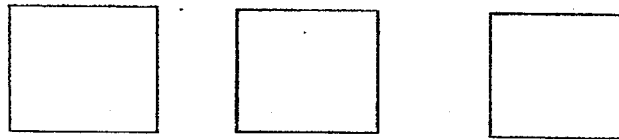

strongest magnet  $\longrightarrow$  weakest magnet

- (b) Melissa wanted to find out the distance travelled by the plastic toy cars fitted with magnets A, B or C as shown below. She observed toy car with magnet A moved away when she pushed the toy car with magnet C towards it.

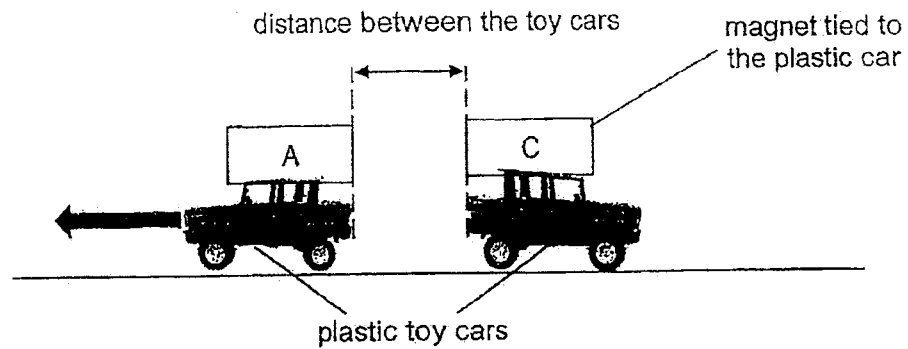

She measured the distance between the two cars and recorded the result in the table below. She repeated the experiment with magnets B and C:

Magnets	Distance between the cars (cm)
A and C	6.0
B and C	?

- (i) Explain why the toy cars with magnets A and C moved away from each other. [1]

---

- (ii) Toy cars with magnets B and C also moved away from each other. Based on the magnetic strength of the magnets in (a), what will likely be the distance recorded between the two toy cars? [1]

---

- (iii) Explain your answer for (b)(ii). [1]

---



---

End Of Paper

Score	4
-------	---

**SCHOOL :** NAN HUA PRIMARY SCHOOL  
**LEVEL :** PRIMARY 3  
**SUBJECT :** SCIENCE  
**TERM :** 2023 SA2

**CONTACT :**

**SECTION A**

<b>Q1</b>	<b>Q2</b>	<b>Q3</b>	<b>Q4</b>	<b>Q5</b>	<b>Q6</b>	<b>Q7</b>	<b>Q8</b>	<b>Q9</b>	<b>Q10</b>
2	2	3	2	2	4	4	1	3	1
<b>Q11</b>	<b>Q12</b>	<b>Q13</b>	<b>Q14</b>	<b>Q15</b>	<b>Q16</b>	<b>Q17</b>	<b>Q18</b>	<b>Q19</b>	<b>Q20</b>
4	3	1	3	4	1	2	1	3	3
<b>Q21</b>	<b>Q22</b>	<b>Q23</b>	<b>Q24</b>						
2	1	3	4						

**SECTION B**

<b>Q25a</b>	C and D
<b>Q25b</b>	Animal B lays eggs and does not have feathers on its body.
<b>Q25c</b>	Animal A does not lay eggs but Animal C lays eggs.
<b>Q25d</b>	Animal D
<b>Q26a</b>	Group X: Fungi Group Y: Reptiles
<b>Q26b</b>	Mammals
<b>Q27a</b>	Set-ups A and C
<b>Q27b</b>	Set-up C
<b>Q27c</b>	Water/moisture is present in Set-up C but not in Set-up A and B.
<b>Q28a</b>	A cockroach has 3 stages in its life cycle but a mealworm beetle has 4 stages in its life cycle.  OR The young of a cockroach looks like the adult/parent but the young of a mealworm beetle does not look like its parent.
<b>Q28b</b>	Stage X looks like the adult but Stage R does not. OR Stage X moves from place to place but Stage R does not. OR Stage X eats/feeds but Stage R does not eat / feed.

Q28c	
Q29a	Description D
Q29b	As the number of weeks increases, the height of the plant increases.
Q29c	Amount of soil / Mass of soil
Q30a	Does not allow light to pass through and is flexible.
Q30b	X. The distance between the highest and lowest point of material X is the least. This means X is the least flexible / most stiff / most rigid. Thus, material X is most suitable for making a food tray as the tray is stable when food is being carried from place to place.
Q30c	Any one of the following: same amount of water / same type of beaker / same wooden block used / same length / same thickness
Q31a	Group C
Q31b	Group B: Metal Group C: Fabric
Q32a	Strength of fabric
Q32b	R. The number of weights placed on R before it tore was the greatest. R is the strongest material. Thus, it will not tear/break/give way easily.
Q33a	Any one of the following: cobalt / nickel / iron
Q33bi & bii	Any 2: increase number of coils of wire around nail / add more batteries / use a battery with a higher voltage / move set-up lower to the tray of paper clips
Q34a	C → A → B
Q34bi	The like poles of magnet A and C are facing each other, so they repel, causing both cars to move away from each other.
Q34bii	Any answer between 0.1cm to less than 6cm
Q34biii	The magnetic strength of magnet B is weaker than magnet A.