

METHODIST GIRLS' SCHOOL (PRIMARY)

PRIMARY 5

FIRST CONTINUAL ASSESSMENT 2009

SCIENCE

BOOKLET A

NAME : _____ ()

CLASS : Pri. 5. _____

Total Time for Booklets A and B : 1h 45 min

DO NOT OPEN THIS BOOKLET UNTIL YOU ARE TOLD TO DO SO.
FOLLOW ALL INSTRUCTIONS CLOSELY.

PART 1

For each question from 1 to 30, four options are given. One of them is the correct answer. Make your choice (1, 2, 3 or 4). Shade the correct oval (1, 2, 3 or 4) on the Optical Answer Sheet.

- 1) A bar magnet, QP, with the poles denoted as shown, is suspended in the air. If another magnet, SR, shown in the diagram is brought near P, how would the bar magnet, QP, move?

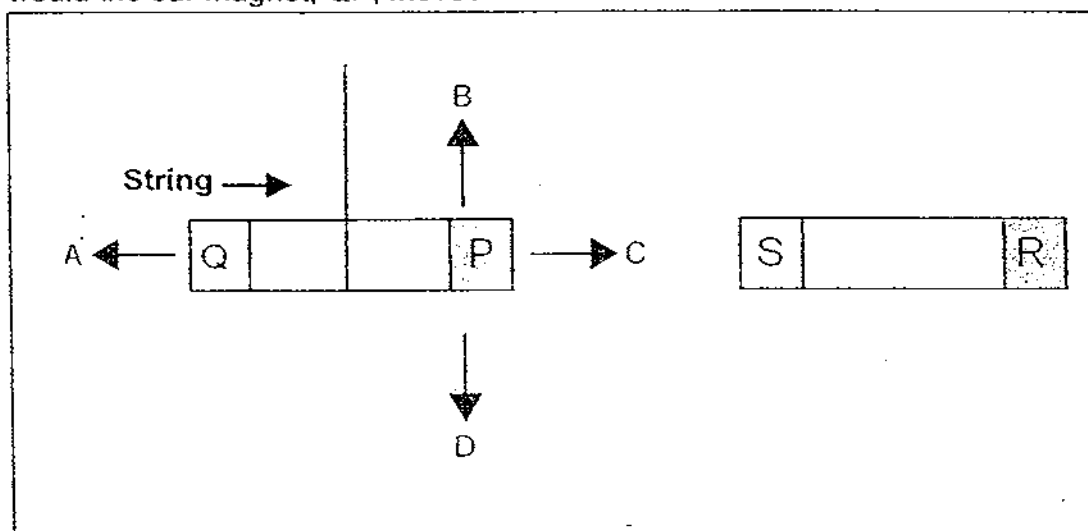

The bar magnet QP would move in the direction of _____.

- (1) A
(2) B
(3) C
(4) D
- 2) Which of the following statements below about light is incorrect?
- (1) Light can be reflected.
(2) Light travels in all directions.
(3) Light travels in a straight line.
(4) Light can pass through opaque objects.

- 3) A wooden bat is placed between a clear red plastic sheet and a screen.

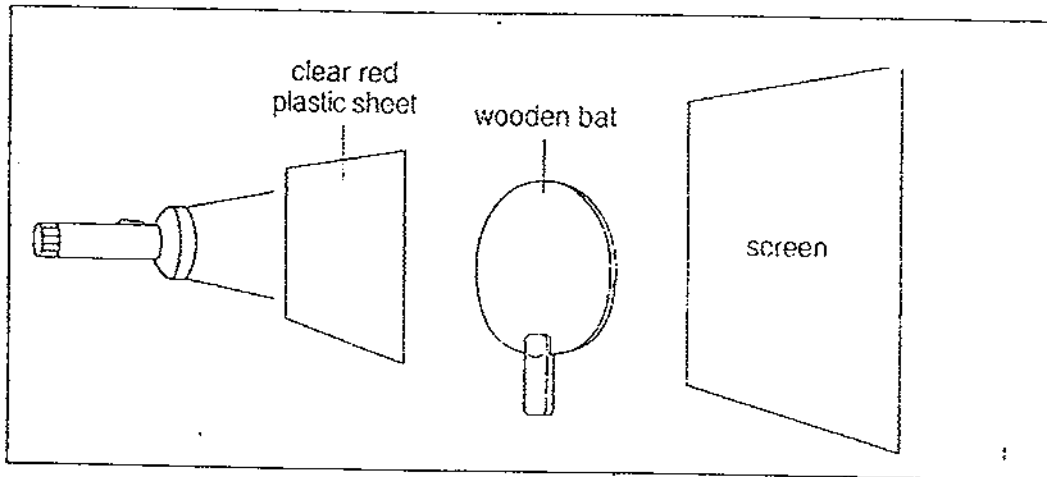

Which of the following images will be seen on the screen?

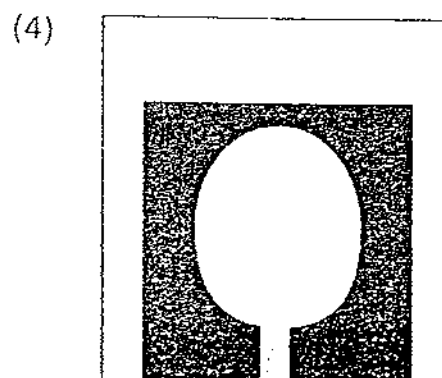
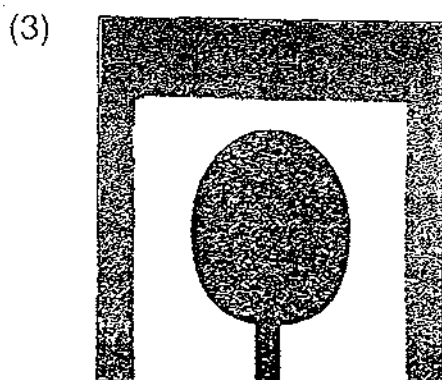
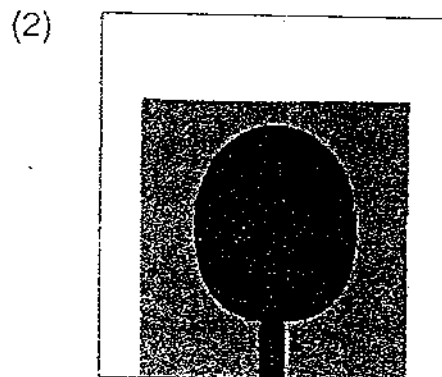
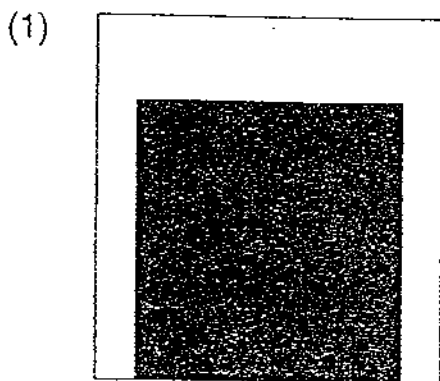

- 4) Study the diagram below carefully.

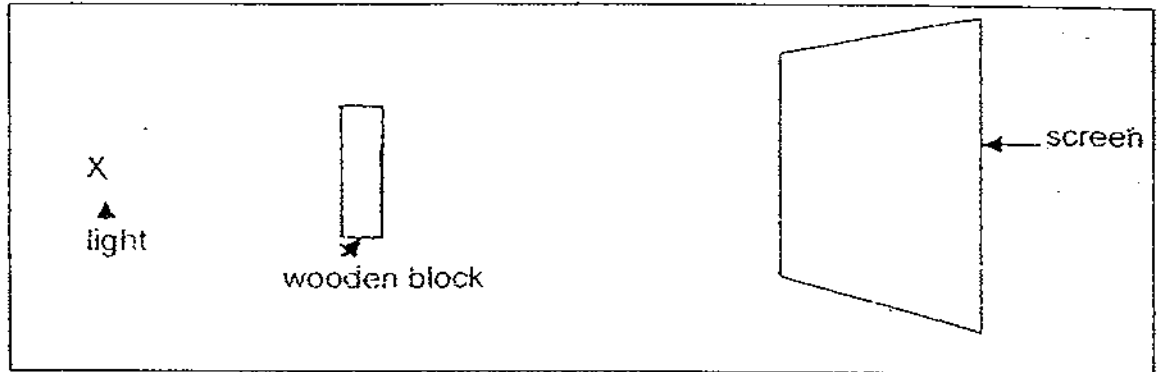

Describe the shadow formed when the wooden block is brought nearer to the screen.

- (1) The shadow is smaller and blurrier.
 - (2) The shadow is smaller and sharper.
 - (3) The shadow is larger and blurrier.
 - (4) The shadow is larger and sharper.
- 5) Mr. Lee found that the light shining through the library window make the place too bright and glaring. If he could change the material of the window to reduce the glare and brightness, which of the following material would be a suitable substitute?
- (1) Steel
 - (2) Clear plastic
 - (3) Soft plywood
 - (4) Frosted glass
- 6) When water is heated to 100°C , bubbles can be seen rising through the water. What do these bubbles contain?
- (1) Hot water vapour
 - (2) Hot water droplets
 - (3) Air dissolved in the water
 - (4) Only oxygen is released from the hot water
- 7) What happens when a piece of ice melts?
- (1) The ice is ~~absorbing~~^{gaining} heat.
 - (2) The ice is absorbing water vapour.
 - (3) The temperature of the ice is rising.
 - (4) The volume of the ice is increasing.

8) When matter gains heat,

- A: it has a greater volume.
- B: its temperature increases.
- C: it has more mass.
- D: it may change from one state to another.

- (1) A and B only
- (2) C and D only
- (3) A, B and D only
- (4) All of the above

9) A block of ice is left to melt at room temperature and then put to boil until all the water has evaporated.

Which of the following graphs shows the correct changes?

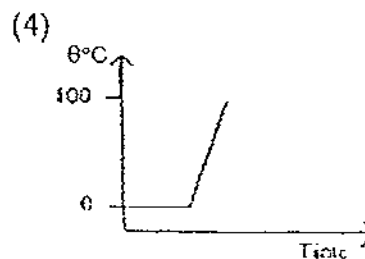
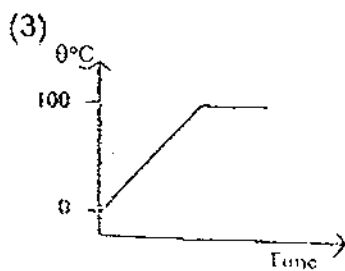
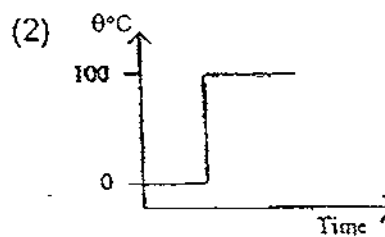
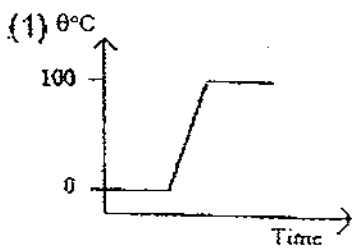

- 10) Leela placed a metal coin on a plastic sheet and held a magnet under the sheet as shown in the diagram.

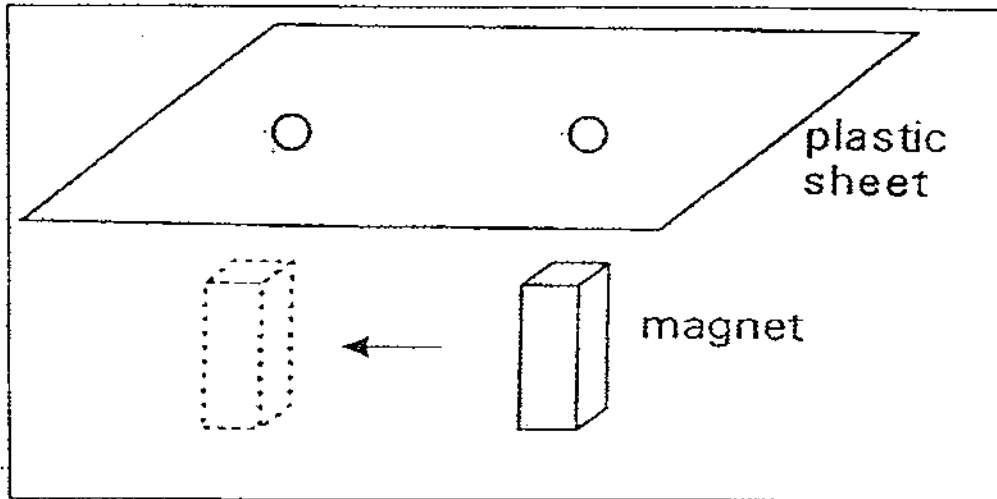

She noticed that when the magnet moved, the metal coin would move in the same direction.

When the plastic sheet was replaced by an iron sheet, the metal coin did not move even when the magnet was moved as shown in the diagram.

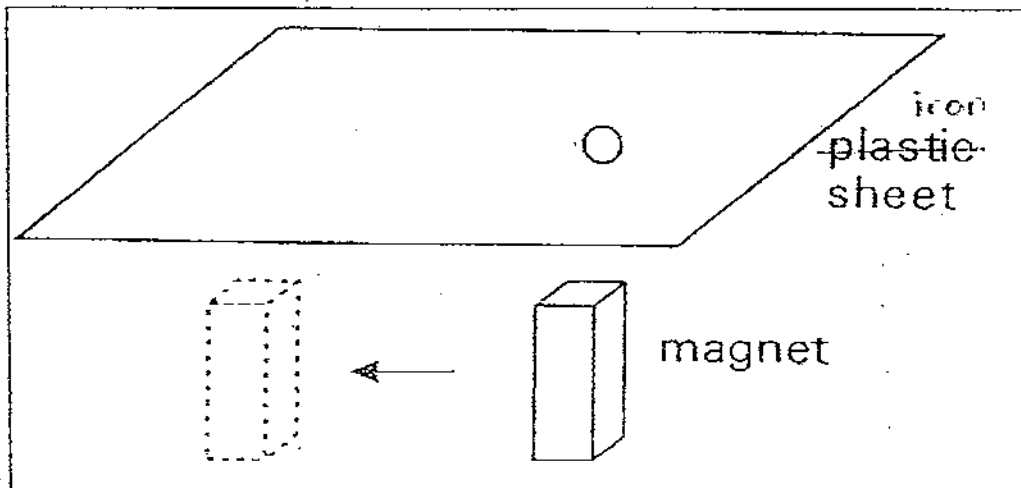

Which of the following correctly explains what happened?

- (1) The iron sheet repelled the metal coin.
- (2) The iron sheet prevented the attraction of the metal coin and the plastic sheet.
- (3) The metal coin was too far from the magnet.
- (4) The metal coin was made of non-magnetic material.

- 11) Ann has 4 objects A, B, C and D. When she puts A into a measuring cylinder containing 10cm^3 of water, the water level rises. She puts B, C and D, one at a time and plots the graph below to show the changes in the water level in the measuring cylinder.

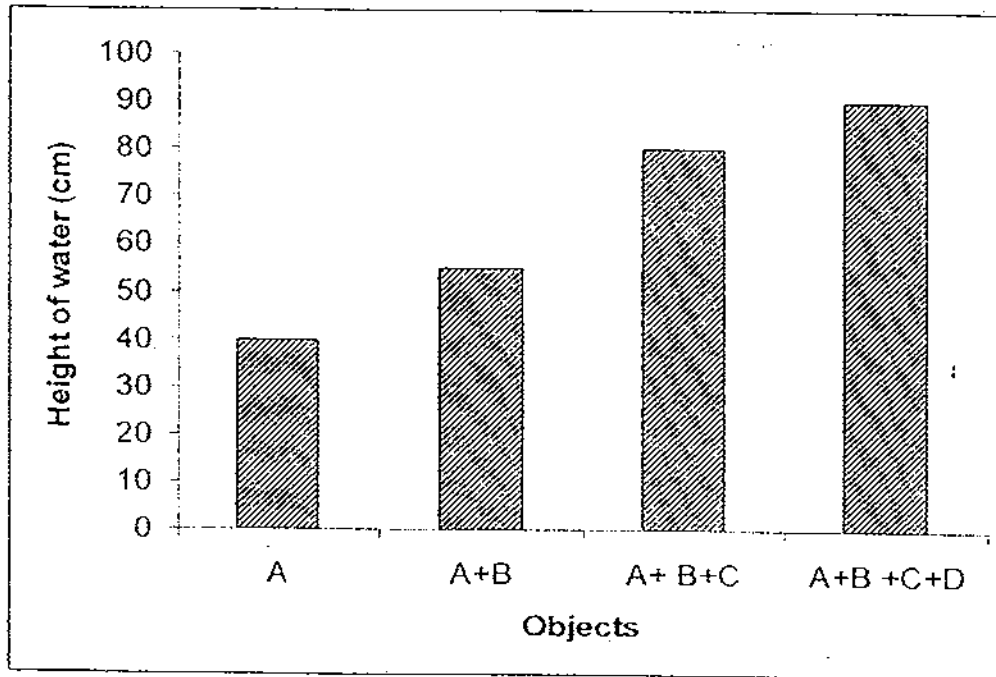

W

Which of the 2 objects have the same volume?

- (1) A and B
- (2) B and D
- (3) B and C
- (4) C and D

- 12) James placed Container A which contains hot water at 80°C to container B containing water of 10°C . The containers are placed on a table in a room. The room temperature is 30°C .

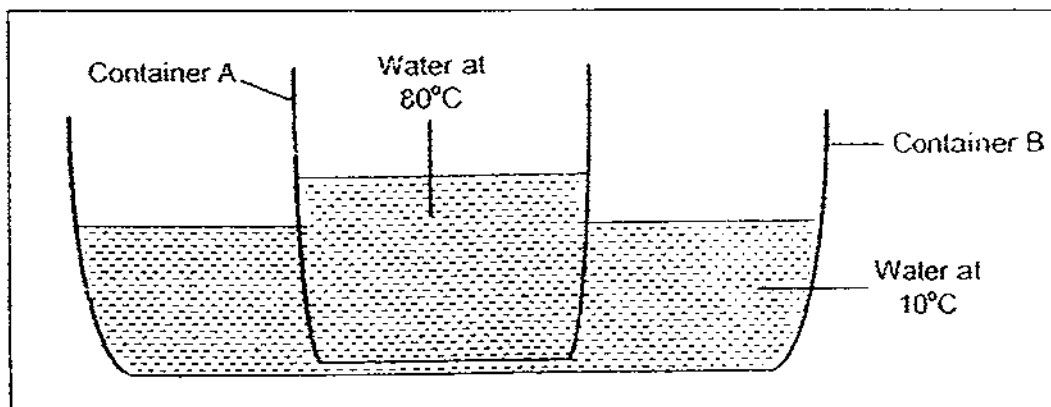

Which of the following statements are true?

- A: Water in both containers loses heat to the surrounding air.
- B: The temperature of the water in container A drops while the temperature of the water in container B rises.
- C: The temperature of the water in both containers will eventually be the same.

- (1) A and B only
(2) A and C only
(3) B and C only
(4) All of the above.

- 13) Anna poured some hot coffee in four identical teapots made of four different materials. She wanted to find out which teapot is the best for keeping the coffee hot over an hour. She then recorded the temperature changes of the coffee from 90°C to 30°C in the four teapots in the following graph.

Which teapot should she use if she wants to keep her coffee for the longest possible time?

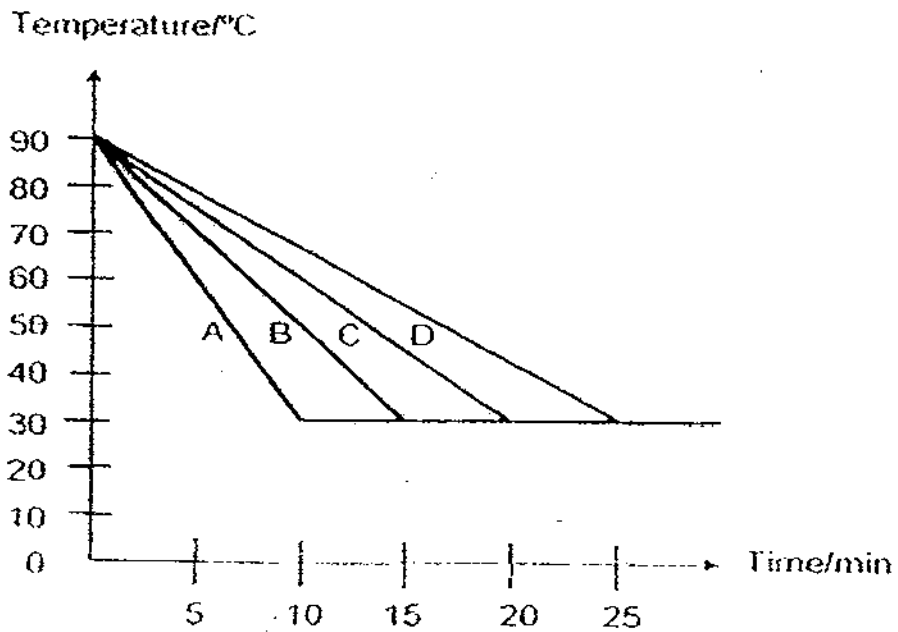

- (1) A
- (2) B
- (3) C
- (4) D

14) Lionel planted some seeds in a pot. He watered them every day. After a few weeks, plants grew in the pot. Later, the plants died. Which of the following is/are correct conclusion(s) of this experiment?

- A: Plants can grow over time.
- B: Plants come from seeds.
- C: Plants will die.
- D: Plants need water.

- (1) A only
- (2) A and B
- (3) A, C and D
- (4) B, C and D

15) The diagram below shows the stages in the growth of a seed to a young plant. At which stage is sunlight necessary for it to grow?

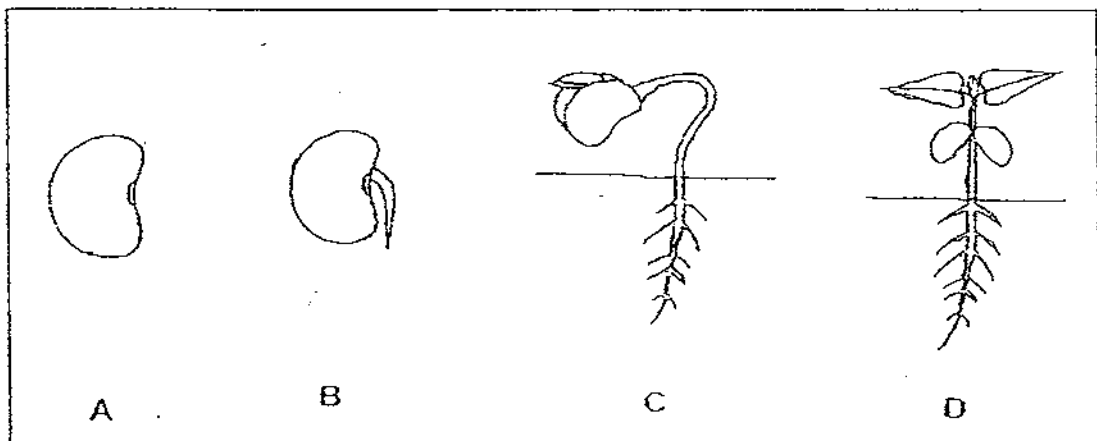

- (1) A only
- (2) D only
- (3) B, C and D only
- (4) All of the above

- 16) Four children were asked to name one difference between photosynthesis and respiration.

Alice: During photosynthesis, energy is produced and stored in the form of food while during respiration, energy is released from food.

Brian : Photosynthesis replenishes oxygen in the air but respiration uses oxygen from the air.

Cathy : Photosynthesis only takes place inside plant cells while respiration only takes place inside animal cells.

Daniel: Photosynthesis uses carbon dioxide while respiration produces carbon dioxide.

Which of the children is/are correct?

- (1) Only Brian, Cathy and Daniel
 - (2) Only Alice, Brian and Cathy
 - (3) Only Alice, Brian and Daniel
 - (4) All of them
- 17) Study the classification table below.

	Number of stages in life cycle	Type of animal
A	3	Insect
B	4	Insect
C	3	Amphibian

What can A, B and C be?

	A	B	C
(1)	Stick insect	Mosquito	Crocodile
(2)	Cockroach	Butterfly	Toad
(3)	Ant	Grasshopper	Frog
(4)	Firefly	Butterfly	Lizard

18) Study the flow chart below carefully.

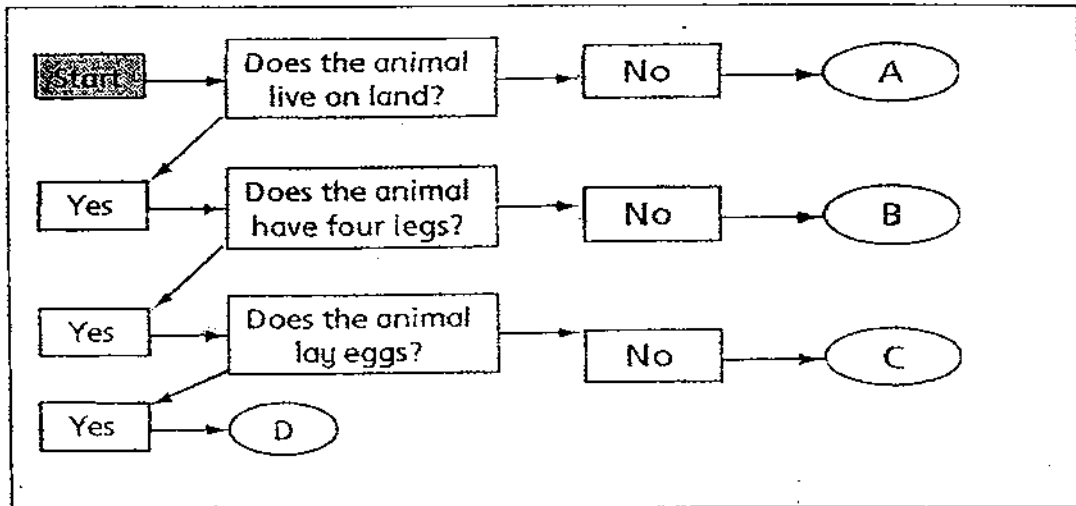

Which of the following animals can be placed at C?

- (1) Chicken
- (2) Grasshopper
- (3) Tilapia
- (4) Lion

19) Some animals have been put into 3 groups, A, B and C based on the number of stages in their life cycles.

Group A (2 stages)	Group B (3 stages)	Group C (4 stages)
Chimpanzee	Mosquito	Damselfly
Panther	Cockroach	Butterfly
Man	Dragonfly	Mealworm beetle

Which animals have been classified wrongly?

- (1) Panther, Butterfly
- (2) Mosquito, Damselfly
- (3) Chimpanzee, Dragonfly
- (4) Dragonfly, Mealworm beetle

20)

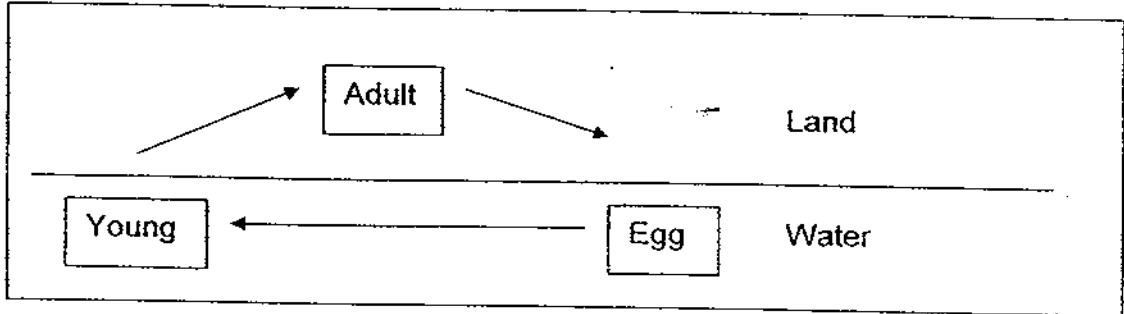

Which of these animals go through the same life cycle as the above?

- (A) Toad
- (B) Mosquito
- (C) Damselfly
- (D) Prawn

- (1) A only
- (2) A and B
- (3) A, B and C
- (4) A, C and D

21) Which of the following statements about yoghurt making are true?

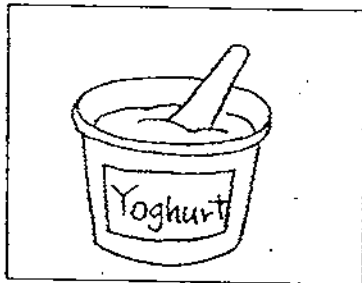

- A: Bacteria are added.
- B: Fermentation of milk takes place.
- C: Oxygen is needed.
- D: Yeast cells are added.

- (1) A and B only
- (2) B and D only
- (3) A, B and C only
- (4) B, C and D only

- 22) The graph below shows the number of days in each stage of the life cycle of an insect.

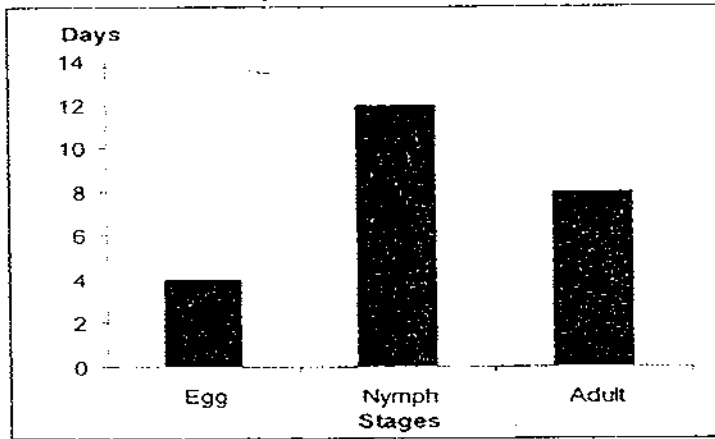

Which one of the following information obtained from the graph is correct?

- (1) The insect can only survive for 1 week.
 - (2) There are 3 stages in the life cycle of this insect.
 - (3) The insect lives in the water for 12 days as a nymph.
 - (4) It takes 24 days to become an adult after the egg is hatched.
- 23) The diagram below shows the human respiratory system. Which of the following correctly shows the movements of the ribs and diaphragm during inhalation and exhalation?

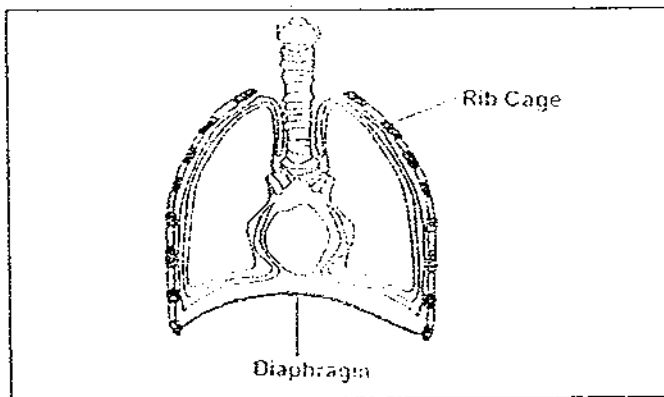

	Ribs		Diaphragm	
	Inhalation	Exhalation	Inhalation	Exhalation
(1)	Down and outwards	Up and inwards	Relaxes	Contracts
(2)	Down and inwards	Up and outwards	Relaxes	Contracts
(3)	Up and outwards	Down and inwards	Contracts	Relaxes
(4)	Up and inwards	Down and outwards	Contracts	Relaxes

- 24) The diagram below shows how blood is circulated in our body.

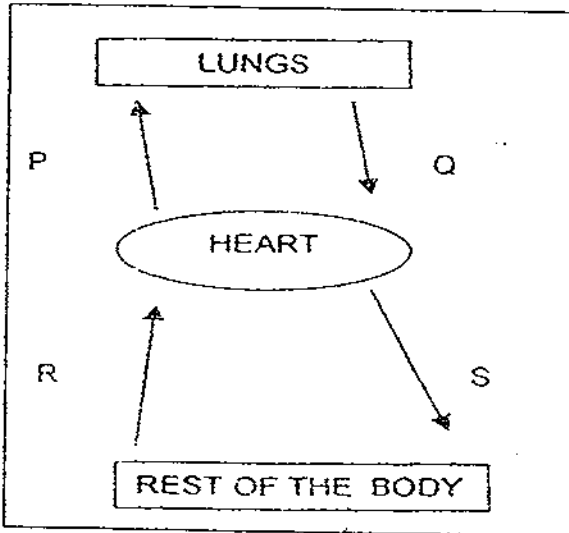

Which one of the following is correct about the amount of oxygen in our blood as it is transported in our body?

	More oxygen at	Less oxygen at
(1)	P and Q	Q and S
(2)	Q and S	P and R
(3)	P and S	Q and R
(4)	R and S	P and Q

- 25) Which of the following differences is incorrect about the air that is inhaled and air that is exhaled?

Inhaled air	Exhaled air
(1) more oxygen	less oxygen
(2) less carbon dioxide	more carbon dioxide
(3) higher temperature	lower temperature
(4) less water vapour	more water vapour

- 26) One evening, Lily strolled to a nearby park. On the way, she was chased by a dog. She ran as quickly as she could until she lost sight of the dog. She panted and rested for a while before she continued her walk.

Which of the following graphs show the likely changes in Lily's heart rate that evening?

(1)

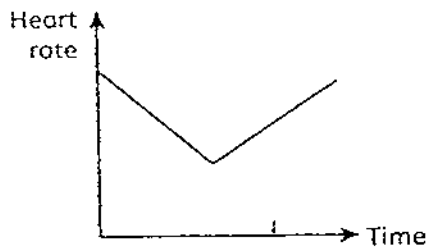

(2)

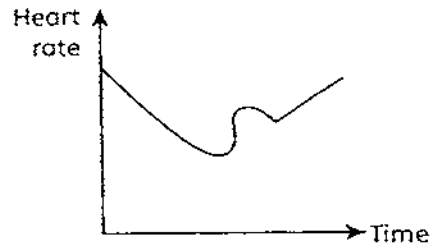

(3)

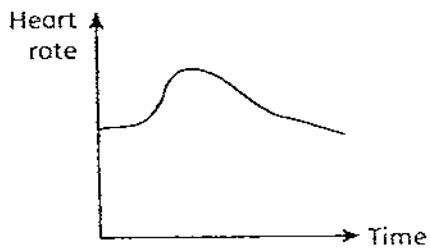

(4)

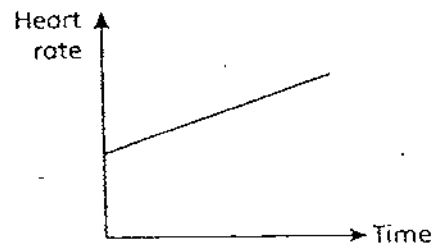

27) The diagram below shows some organ systems in our body.

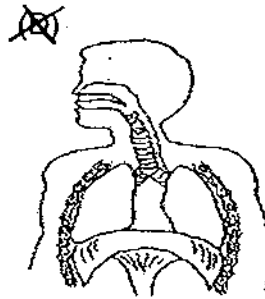
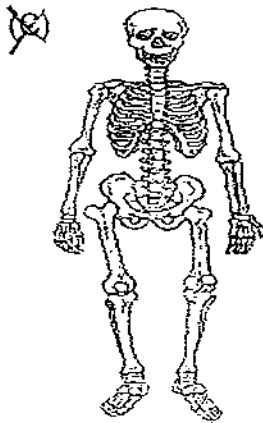
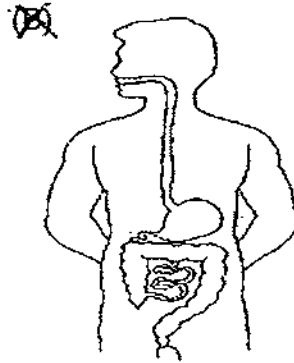
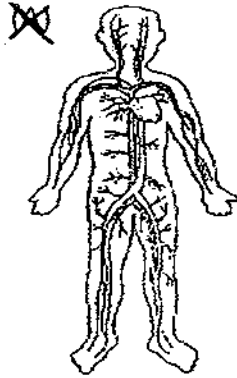

Which two systems work together to remove carbon dioxide produced in the body cells efficiently?

- (1) A and B
- (2) A and D
- (3) B and C
- (4) B and D

28) Sam performed four different activities and recorded her heart rate in a graph shown below.

Which of the following shows the correct activity for A, B, C and D?

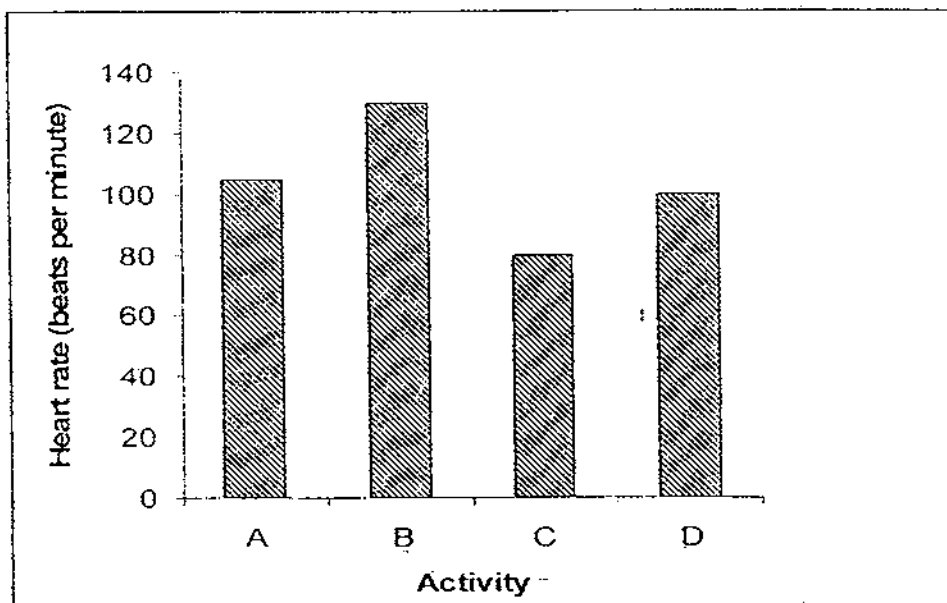

A	B	C	D
(1) Swimming	Cycling	Jogging	Dancing
(2) Walking	Jogging	Cycling	Reading
(3) Listening to music	Walking	Jogging	Swimming
(4) Running	Swimming	Listening to music	Jumping

29) Study the graphic organizer below.

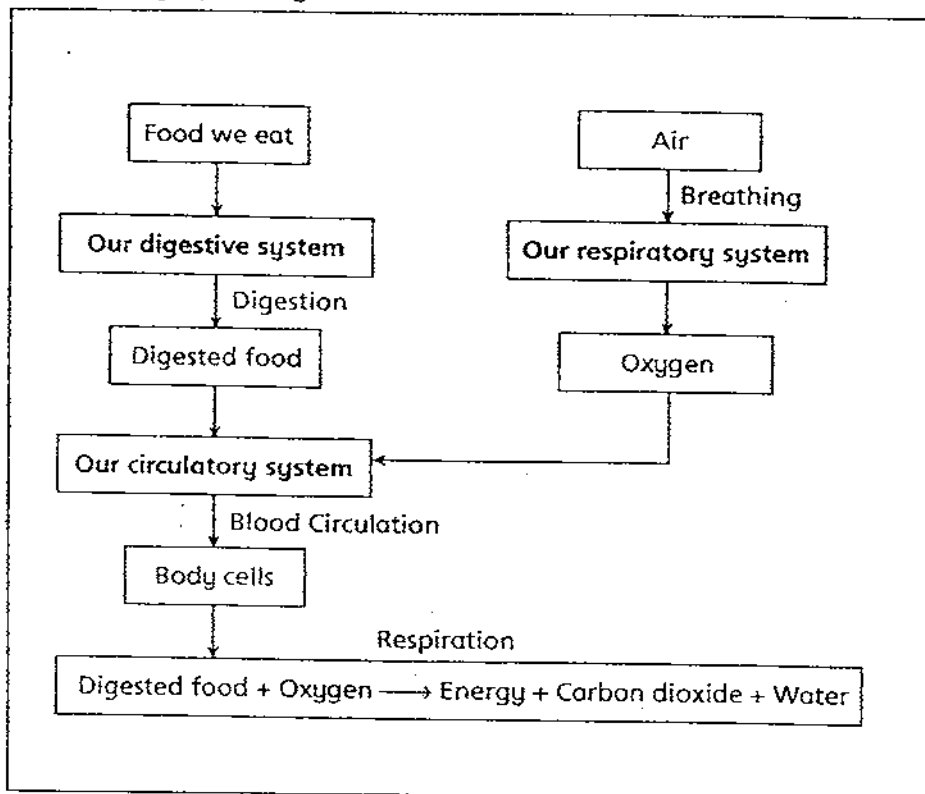

What information can you deduce from the graphic organiser?

- A: Different systems in our body work together so that our body cells can carry out respiration.
- B: Digestion and breathing take place in our circulatory system.
- C: Our circulatory system transports digested food and oxygen to the cells in our body.
- D: The food we eat is completely digested in the small intestine in our digestive system.

- (1) A and C only
- (2) B and D only
- (3) A, C and D only
- (4) A, B, C and D only

- 30) The diagram below shows the human skeletal system with joints A, B, C and D.

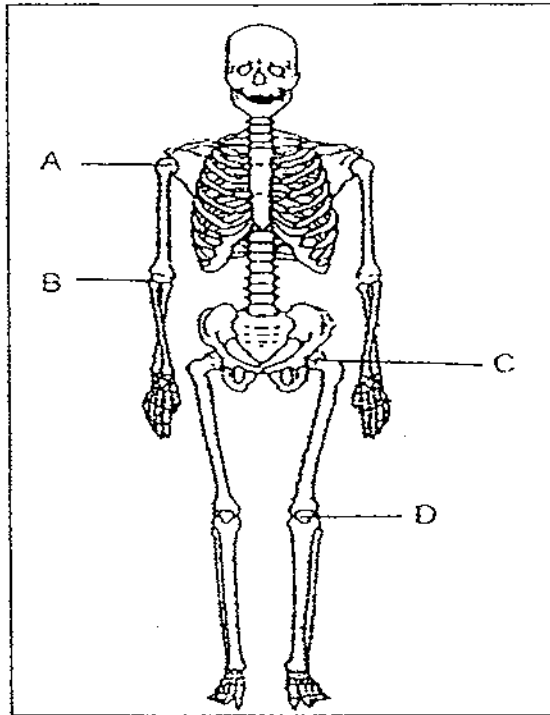

Which one of the following shows the correct classification?

Types of movement	
In all directions	In one direction
(1) A, C	B, D
(2) A, B, C	D
(3) A, B	C, D
(4) A, C, D	B

METHODIST GIRLS' SCHOOL (PRIMARY)

PRIMARY 5

CONTINUAL ASSESSMENT 2009

SCIENCE

BOOKLET B1

Physical Science

SECTION	MARKS
A (60 marks)	
B1 (17 marks)	
B2 (23 marks)	
TOTAL (100 marks)	

NAME : _____ ()

CLASS : Pri. 5. _____

Total Time for Booklets A and B : 1h 45 min

DO NOT OPEN THIS BOOKLET UNTIL YOU ARE TOLD TO DO SO.
FOLLOW ALL INSTRUCTIONS CLOSELY.

PART 2

For questions 31 to 45, write your answers in this booklet.

The number of marks available is shown in brackets () at the end of each question or part question. (40 marks)

31) John sets up an experiment as shown below.

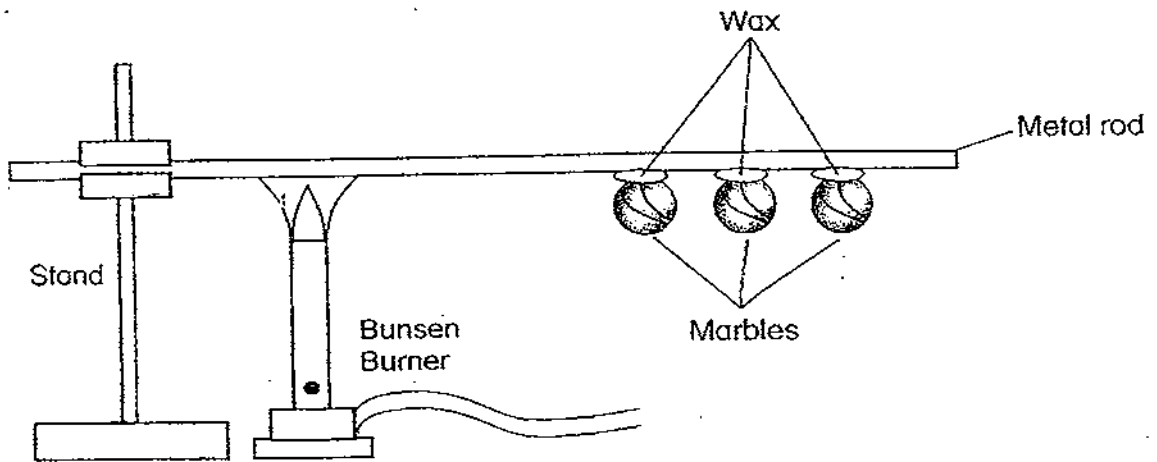

a) What do you think will happen? (1 m)

b) What is John trying to prove from the experiment above? (1 m)

32) Jane wondered why Aunt May covered some blocks of ice with a sack.

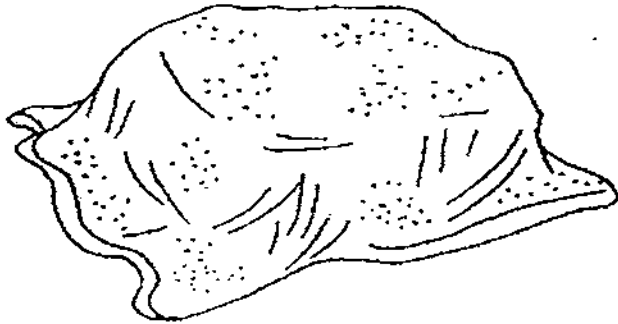

a) What is the purpose for Aunt May to do that? (1m)

b) What happens to the ice after several hours? (1m)

c) Explain your answer in (b). (1m)

33) Dolly shone a torch on the mask. The shadow of the mask was cast on a screen as shown in the diagram below.

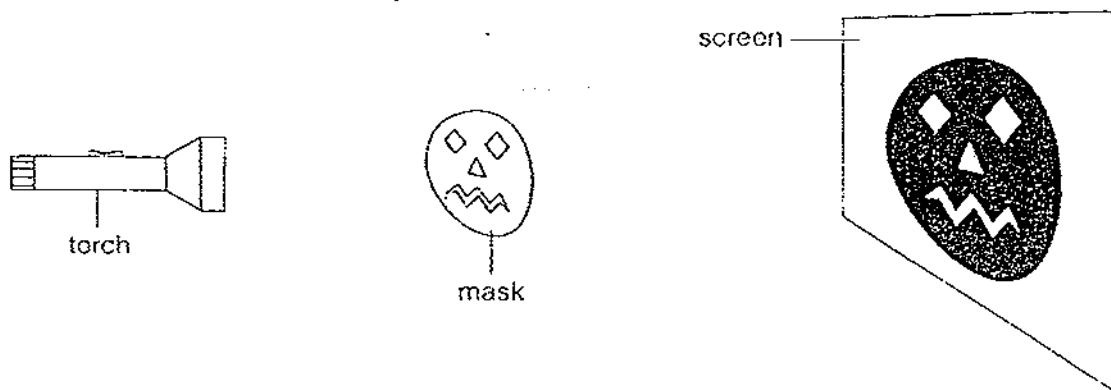

A set of variables were measured and the results were recorded in the table below.

Distance from the light source to the mask (cm)	Height of the shadow of the mask on the screen (cm)
50	65
60	53
70	40

a) Based on the table, what is the relationship between the distance from the light source to the mask and the height of the shadow of the mask on the screen. (1m)

b) List one important variable that was kept the same in the above experiment. (1m)

34) In the set-up below, Magnet A, B and C are of similar strength.
Magnet C is held in place by Magnet A as shown.

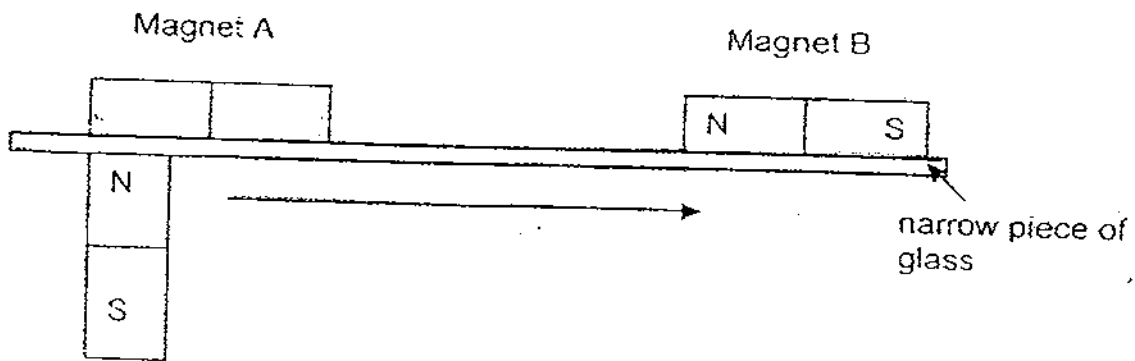

Magnet C

a) What will happen if Magnet C moves in the direction as indicated by the arrow? (1m)

b) If Magnet A were to be replaced by a piece of wood which is similar in size, what do you think will happen? (1m)

35) A sponge seller wanted to pack a sponge of edge 8 cm into a cardboard box of edge 7cm.

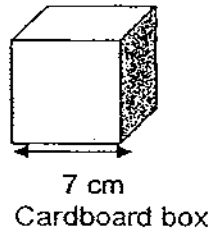
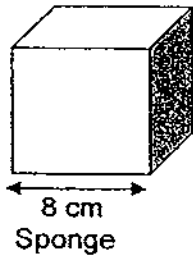

Would he be able to pack the sponge into the box?
Explain your answer.

(2 m)

36) Linda was given a mixture of salt granules and green beans. She was also given a stirrer, some water in a beaker and an empty beaker with a funnel and filter paper. Describe what Linda could do so that the green beans could be separated from the mixture. (2 m)

- 1) A mixture of salt granules and green beans
- 2) A stirrer
- 3) Some water in a beaker
- 4) An empty beaker
- 5) A funnel with a piece of filter paper placed on it

Step 1	Pour the mixture into the beaker of water.
Step 2	
Step 3	
Step 4	

37) Jessica and Tammie set up the following experiment as shown.
 A 800 ml beaker was filled with water and inverted into a trough of water as shown below.

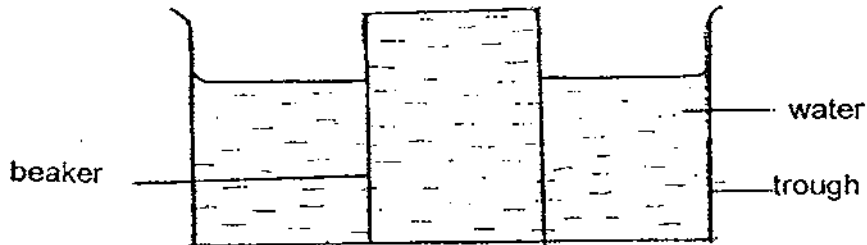

Jessica used a plastic tube to blow some air into the beaker. The height of the water was recorded. Following that, Tammie blew some air into the beaker and the height of the water was again recorded. The results are tabulated in the following table.

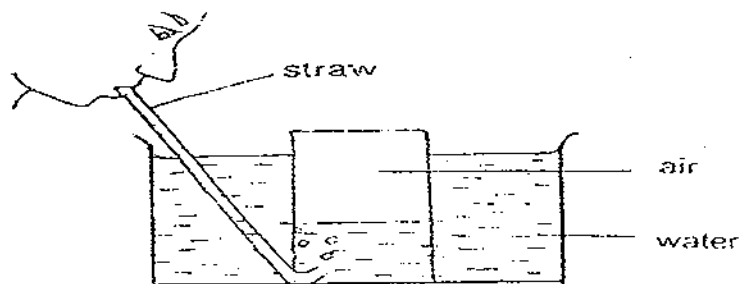

	Height of water in the glass (cm)
At the start of the experiment	75 ^{beaker}
After Jessica had blown	45
After Tammie had blown	20

- a) What is the main reason for the water level in the beaker to go down when Jessica blew into the straw? (1 m)

b) Given that Jessica used the same straw and beaker for the above experiment, state 2 more variables that must be kept the same. (1 m)

c) In another experiment which has the same set up, Jessica decided to suck out some air through the tube. What will happen to the water level in the beaker? (1 m)

d) Explain your answer in (c). (1 m)

METHODIST GIRLS' SCHOOL (PRIMARY)

PRIMARY 5

CONTINUAL ASSESSMENT 2009

SCIENCE

BOOKLET B2

Life Science

SECTION	MARKS
B2 (23 marks)	

NAME : _____ ()

CLASS : Pri. 5. _____

Total Time for Booklets A and B : 1h 45 min

DO NOT OPEN THIS BOOKLET UNTIL YOU ARE TOLD TO DO SO.
FOLLOW ALL INSTRUCTIONS CLOSELY.

38) Adeline selected a plant and removed the outermost covering of a branch. She left the plant to continue growing for several weeks.

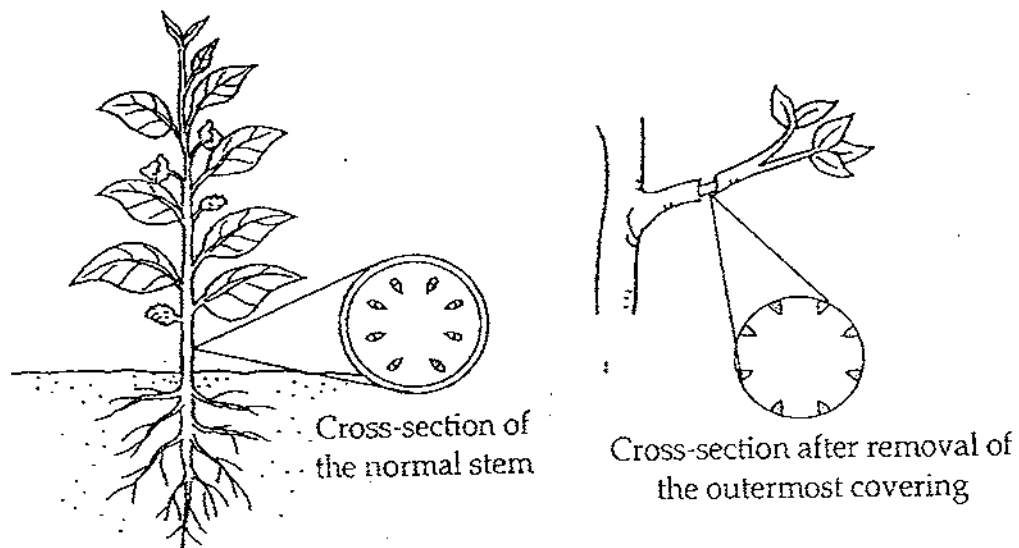

a) What would happen when Adeline removed the outermost covering of the branch? (1 m)

b) Predict what Adeline will see after two weeks. (1 m)

c) Which part of the branch was removed in the outermost covering? (1 m)

39) The diagram below shows a mushroom.

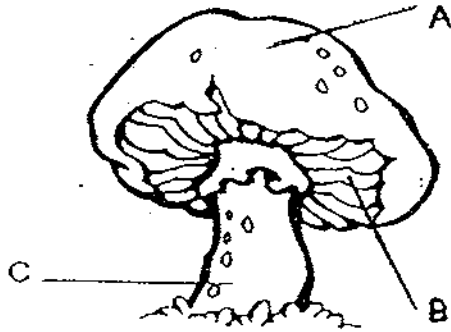

a) Based on the diagram above, where are the spores of the mushroom found?
Write the letter A, B or C and label the part. (1m)

Part: _____

b) State how bacteria are considered to be both useful and harmful to Man. (2m)

Useful	
Harmful	

40) The diagram below shows how blood is circulated around the body via Organ A. Arrows indicated by X, Y and Z represent the movement of the blood.

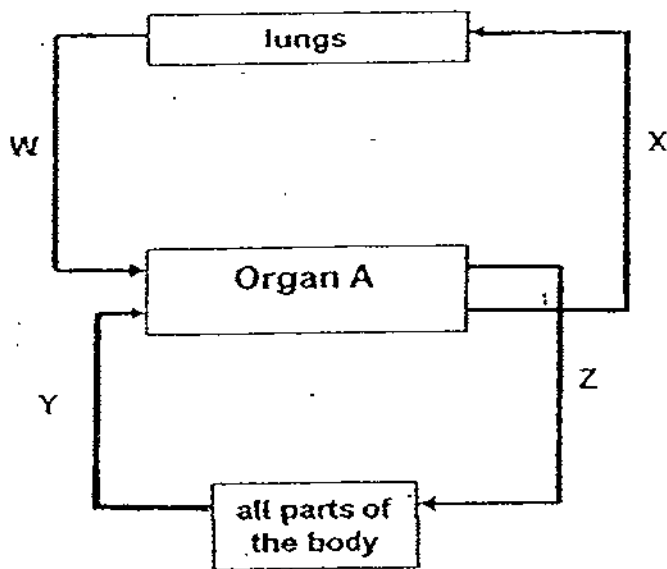

a) Why is gaseous exchange in the circulatory system important to man's survival? (1 m)

b) Which two arrows represent the movement of blood rich in oxygen? (1 m)

c) What causes blood to circulate round our body? (2 m)

- 41) The table below shows 2 differences between breathing and photosynthesis. Complete the table by giving 2 other differences. (2 m)

Differences between	
breathing	photosynthesis
(1) Takes place in all plants and animals.	Takes place only in green plants.
(2) Takes place all the time	Takes place only when there is light.
(3)	
(4)	

- 42) The diagram below shows the magnified cross section of X. There are numerous tiny structures, Y, found within X. Y has a thin wall and contains blood capillaries.

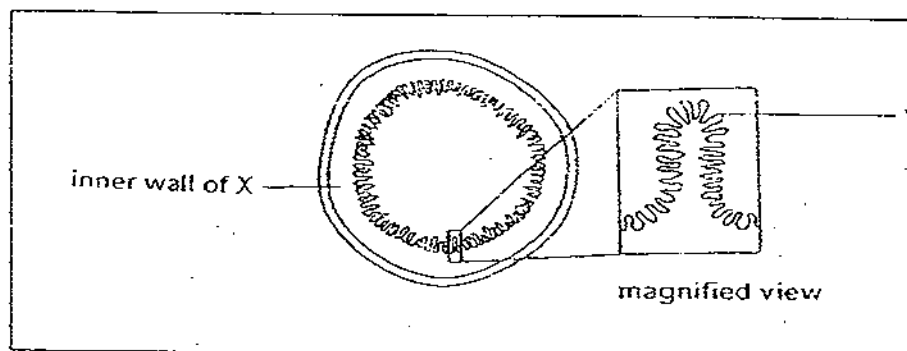

- a) Explain how these tiny structures, Y help the body to absorb food better. (1 m)

- b) Why is it important that digested food is absorbed into the bloodstream? (1 m)

43) The diagram shows the life cycle of a butterfly.

a) Complete the life cycle of the butterfly below.

(2 m)

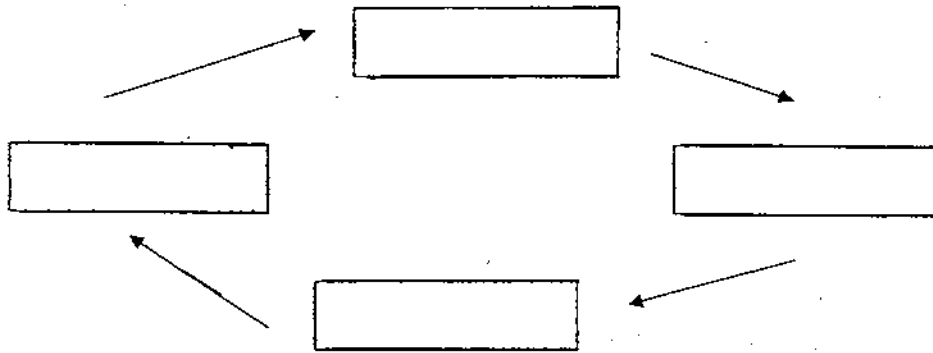

b) Name the two stages that the butterfly can be harmful to plants.

(1 m)

c) Describe how this is so.

(1 m)

d) Like the butterfly, the mosquito has four stages in its life cycle.

One method of controlling the population of the mosquito is to introduce fish into stagnant water.

Name the stage of the mosquito life cycle at which this method will not work.

(1 m)

44) Rachel put a few grasshoppers in a plastic bag. She knew that all living things need air to survive, so she blew air into the plastic bag and tied the mouth of the bag. To her surprise, the grasshoppers died after a short while.

Explain why did the grasshoppers die?

(2 m)

45) Study the flow chart below.

(2 m)

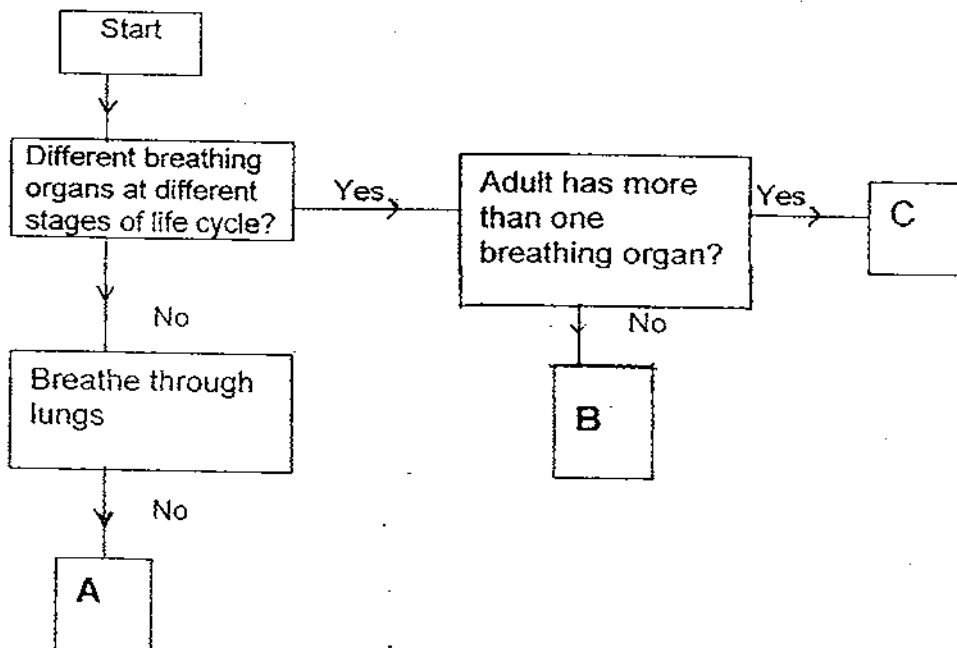

Write down an animal represented by the letter.

A: _____

C: _____

-----END OF PAPER-----

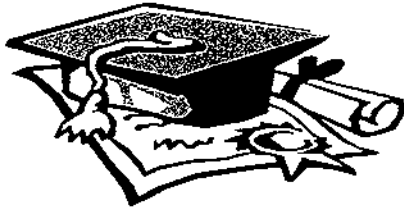

ANSWER SHEET

EXAM PAPER 2009

SCHOOL : M G S PRIMARY SCHOOL

SUBJECT : PRIMARY 5 SCIENCE

TERM : CA 1

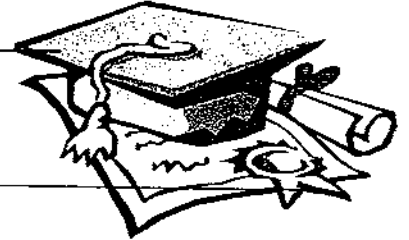

Q1	Q2	Q3	Q4	Q5	Q6	Q7	Q8	Q9	Q10	Q11	Q12	Q13	Q14	Q15	Q16	Q17
3	4	2	2	4	3	1	3	1	2	3	3	4	2	2	3	2

Q18	Q19	Q20	Q21	Q22	Q23	Q24	Q25	Q26	Q27	Q28	Q29	Q30
4	2	2	1	2	3	2	4	3	2	4	1	1

31)a)As the wax melts, the marble nearest to the Bunsen burner will drop first.

b)It demonstrates that heat travels from the hotter region to the cooler region of the metal rod.

32)a)To prevent the ice from melting too fast.

b)The ice will melt.

c)The ice will gain heat from its surroundings.

33)a)The nearer the light source to the mask, the greater the height of the shadow is.

b)The same mask.

34)a)Magnet B will be pushed off the glass.

b)Magnet C will drop.

35)Yes,he would be able to pack the sponge in the cardboard box.The sponge has a lot of air spaces in Air can be compressed thus the sponge can be squeezed into the cardboard box

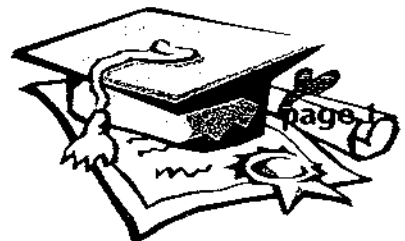

36)1)Stir it with the stirrer.

2)Stir the mixture with a stirrer until the salt granules dissolve.

3)Separate the water containing the dissolved salt granules by using funnel with a piece of filter paper placed on it.

4)The green beans and salt granules are separated.

37)a)There was air occupying space in the beaker.

b)The same amount of water in the beaker and the same trough.

c)The amount of water level in the beaker will increase but the water level in the trough will decrease.

d)Air occupied space in the beaker but when it was sucked out the water took up the empty space in the beaker.

38)a)The plant would not be able to transport food to the part below the section was the outermost covering was removed.

b)The top part of the branch will be swollen.

c)The food-carrying tubes (phloem).

39)a)B

b)Added in bread to make it fluffy.

Causes diseases.

40)a)So that oxygen can be taken in and carbon dioxide to be given out.

b)Arrows W and Z

c)The heart will pump the blood.

41)3)Produces carbon dioxide. Uses carbon dioxide.

4)Energy is produced. Energy is stored.

42)a)They increase the surface area for greater food absorption.

b)It is important as food is needed to be transport to all parts of the body.

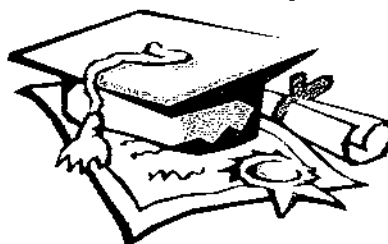

43)a)

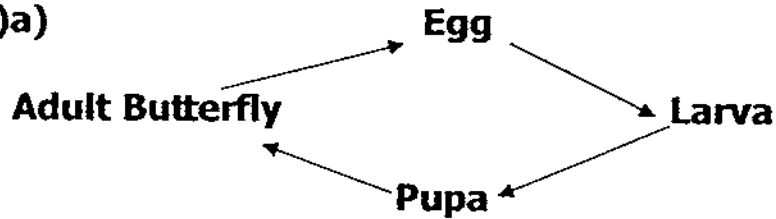

b) Larva and adult.

c) They feed actively on the leaves leaving the plants with few or no leaves to make food for itself.

d) The adult stage.

44) The grasshoppers needed oxygen to breathe but the air Rachel blew into the plastic bag was actually carbon dioxide, so the grasshoppers could not survive without oxygen and died.

45)a) Goldfish

b) Frog



---end---