

METHODIST GIRLS' SCHOOL PRIMARY
SEMESTRAL ASSESSMENT 1, 2008
PRIMARY 6

SCIENCE
(BOOKLET A1)

| |
|--------------------|
| |
| Parent's Signature |

NAME : _____ ()

CLASS : PRIMARY _____

| Booklet | Possible marks | Actual marks |
|---------|----------------|--------------|
| A | 60 | |
| B | 40 | |
| TOTAL | 100 | |

Total time for booklets A and B : 1 hour 45 minutes

Instructions to pupils

DO NOT TURN OVER THE PAGES UNTIL YOU ARE TOLD TO DO SO -
Follow all instructions carefully.
There are 30 questions in this booklet.
Answer all the questions.

Section A: (30 x 2 marks = 60 marks)

For each question from 1 to 30, four options are given. One of them is the correct answer. Make your choice (1, 2, 3 or 4). Shade the correct oval (1, 2, 3 or 4) on the Optical Answer Sheet.

1. Study the flowchart below and identify A, B, C and D.

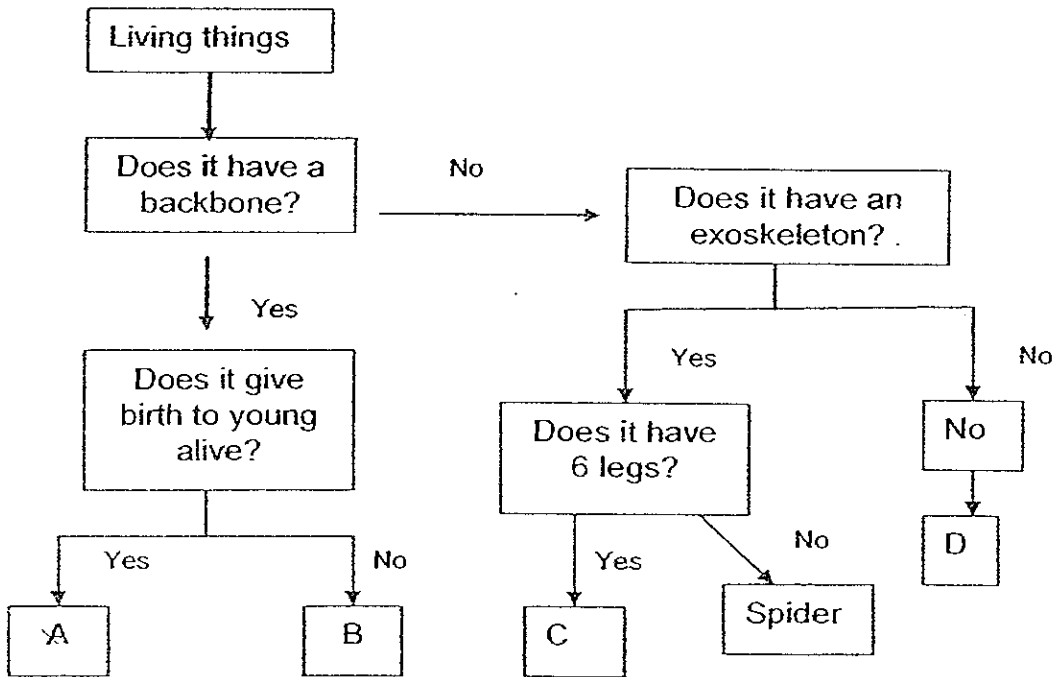

| | A | B | C | D |
|----|----------|-----------|-----------|-------------|
| 1. | Koala | Ostrich | Scorpion | Roundworm |
| 2. | Guppy | Kiwi | Dragonfly | Giant squid |
| 3. | Dog | Porcupine | Honey bee | Crab |
| 4. | Kangaroo | Whale | Ant | Earthworm |

Go to page 2

2. The diagram below shows an amoeba undergoing a cycle of cell division.

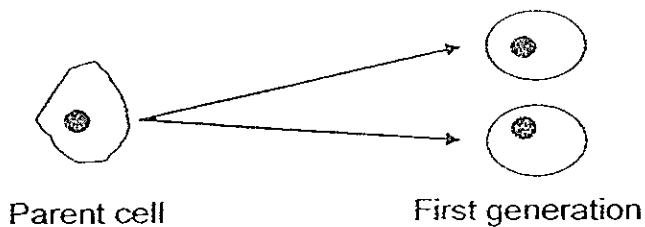

How many cells are formed at the 5th generation?

- (1) 4
- (2) 8
- (3) 32
- (4) 64

3. Study the family tree of the Tan family.

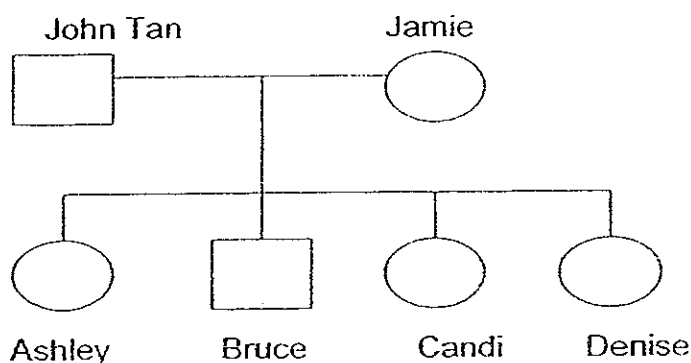

The table below summarises the physical traits of the family.

| | Can roll tongue | Suffers from haemophilia | Colour – blind |
|--------|-----------------|--------------------------|----------------|
| John | No | Yes | Yes |
| Jamie | Yes | No | No |
| Ashley | No | Yes | No |
| Bruce | Yes | Yes | Yes |
| Candi | No | No | No |
| Denise | Yes | No | No |

Which child / children inherited at least one trait from his / her parents?

- (1) Bruce only
- (2) Denise only
- (3) Ashley and Candi only
- (4) All the children

Go to page 3

4. Which of the following statement/statements is/are true about sexual reproduction in both flowering ^{plants} and most animals?

- A : The male reproductive cells are called sperms.
- B : The female reproductive cells are stored in the ovary.
- C : The fertilization process takes place in the female reproductive system.
- D : The male and female organisms have to meet for fertilization to take place.

- (1) A only
- (2) B only
- (3) B and C only
- (4) A and D only

5. Sally was walking along the beach and she observed that the plants on the beach were growing in a particular pattern. She drew her observation as shown on the diagram below.

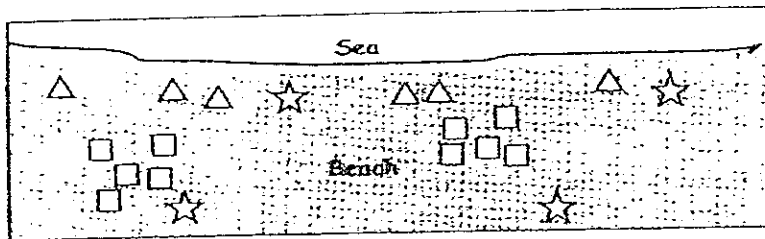

| Legend | |
|--------|-----------|
| △ | - plant A |
| □ | - plant B |
| ☆ | - plant C |

How are the seeds of the 3 different plants most likely scattered?

| | PLANT A | PLANT B | PLANT C |
|-----|-----------|-----------|-----------|
| (1) | Wind | Animal | Water |
| (2) | Water | Splitting | Animal |
| (3) | Splitting | Water | Wind |
| (4) | Animal | Wind | Splitting |

Go to page 4

6.

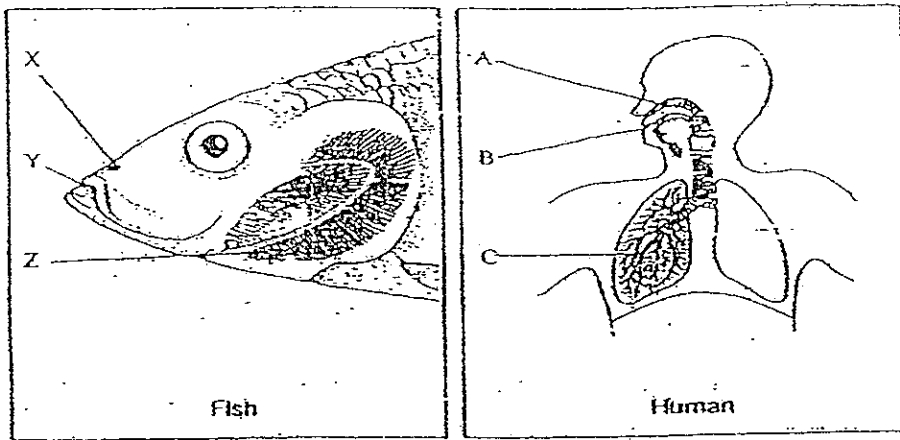

The diagrams below show the respiratory systems of 2 organisms.
Which part of the respiratory system of the fish and human allow exchange of gases to take place?

| | Fish | Human |
|-----|------|-------|
| (1) | X | A |
| (2) | Y | A |
| (3) | Y | B |
| (4) | Z | C |

7. P, Q, R and S represent blood vessels in the diagram below. Which of the following blood vessels contains oxygen-rich blood?

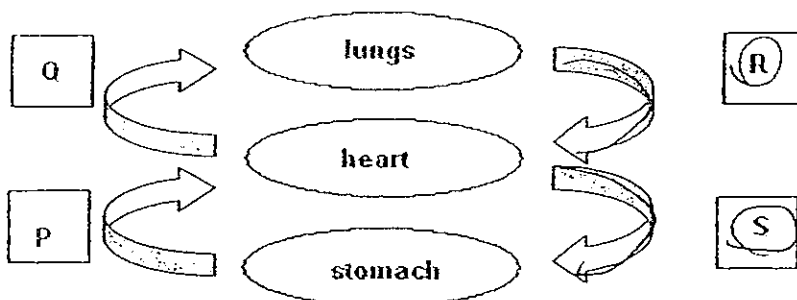

- (1) P and R
- (2) Q and R
- (3) Q and S
- (4) R and S

Go to page 5

8. A well-watered flowering plant is placed in a glass container as shown below. The amount of carbon dioxide and oxygen found in the container at the start of the experiment is as shown below.

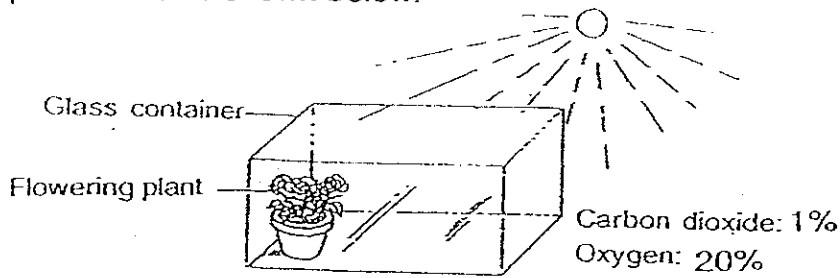

If the rate of photosynthesis is faster than the rate of respiration, which one of the following shows the most likely amount of the gases in the glass container after a few hours?

| | Carbon dioxide | Oxygen |
|-----|----------------|--------|
| (1) | 10% | 10% |
| (2) | 2% | 20% |
| (3) | 0.5% | 40% |
| (4) | 20% | 10% |

9. May conducted an experiment using similar string bean seedlings in pots of the same size over 2 weeks. She tabulated the results in the table below.

| Pot | Type of soil | Amt. of water | No. of times string bean seedlings are watered each day | No. of string bean seedlings in each pot | Average height of string bean seedlings in each pot (cm) |
|-----|--------------|---------------|---|--|--|
| A | Sandy | 50 ml | 3 | 5 | 8.9 |
| B | Loamy | 50 ml | 3 | 10 | 7.7 |
| C | Sandy | 50 ml | 3 | 10 | 6.0 |
| D | Loamy | 50 ml | 3 | 5 | 10.8 |

Which of the following are possible aims for May's experiment?

- A : To find out if overcrowding affects the growth of the seedlings.
- B : To find out if the size of pot used affects the growth of the seedlings.
- C : To find out if the type of soil used affects the growth of the seedlings.
- D : To find out if the amount of water used affects the growth of the seedlings.

- (1) A and D only
- (2) C and D only
- (3) B and C only
- (4) A and C only

Go to page 6

10. Sandy wanted to conduct an experiment to show that the number of leaves on a plant affects the amount of water evaporated from the container. She put four similar plants into 4 similar pots containing the same amount of water.

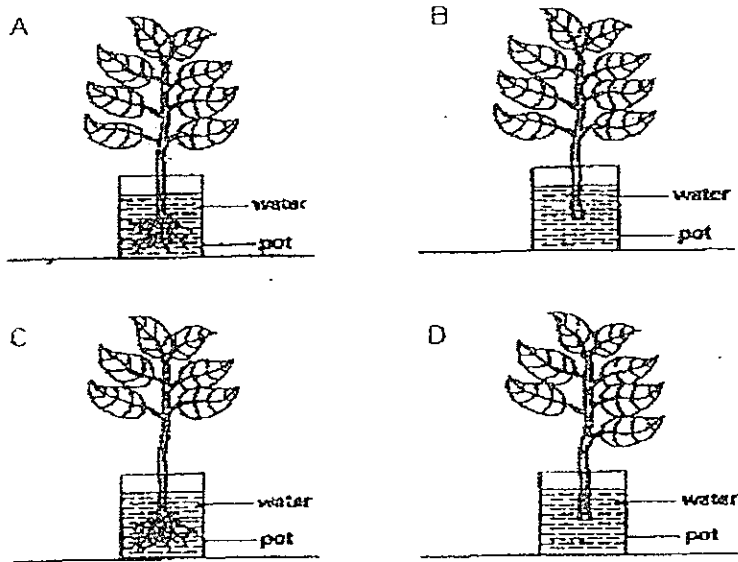

Which of the following set-ups can be used in her experiment?

- (1) A and C
- (2) A and D
- (3) B and C
- (4) C and D

Go to page 7

11. The diagram below shows a food web in the rice fields.

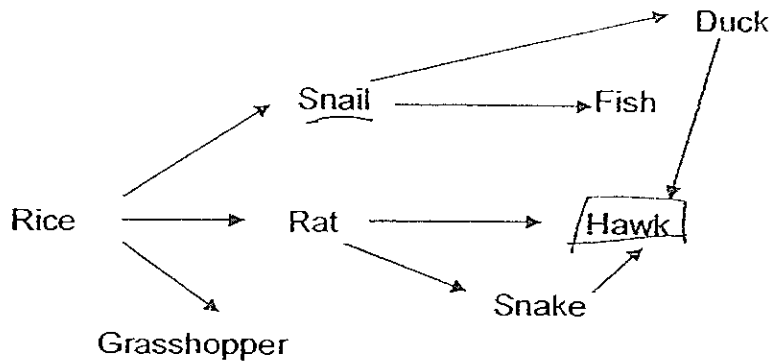

A population of Animal Z invaded the field. As a result, the population of snails decreased and the number of rats increased. Which of the following animals did Animal Z feed on?

- (1) Fish
- (2) Duck
- (3) Snake
- (4) Grasshopper

12. In the food web below, an increase in the eagle population is likely to cause _____.

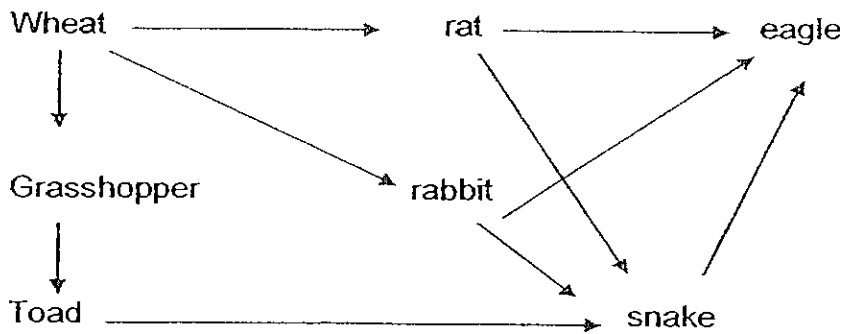

- A : an increase in the wheat population
- B : an increase in the snake population
- C : a decrease in the toad population
- D : no change in the rabbit population

- (1) A only
- (2) A and B only
- (3) B and D only
- (4) A, B and C only

Go to page 8

13. The diagram below shows a mango tree with some living organisms.

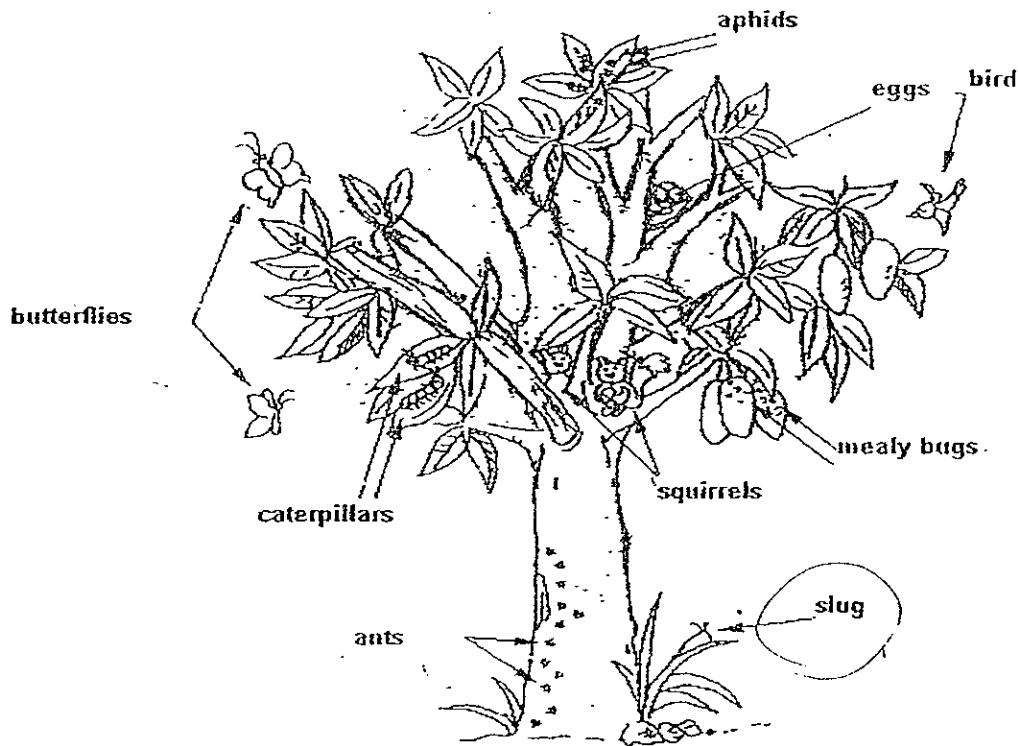

Based on the picture, which of the following statements is correct?

- (1) There are eight communities of living things.
- (2) All the living organisms on the tree are herbivores.
- (3) There are ^{at least} five populations of animals living on the tree.
- (4) All the living organisms in the picture are food consumers.

Go to page 9

14. Study the following organisms. Which of the following breathing methods do not match the organisms?

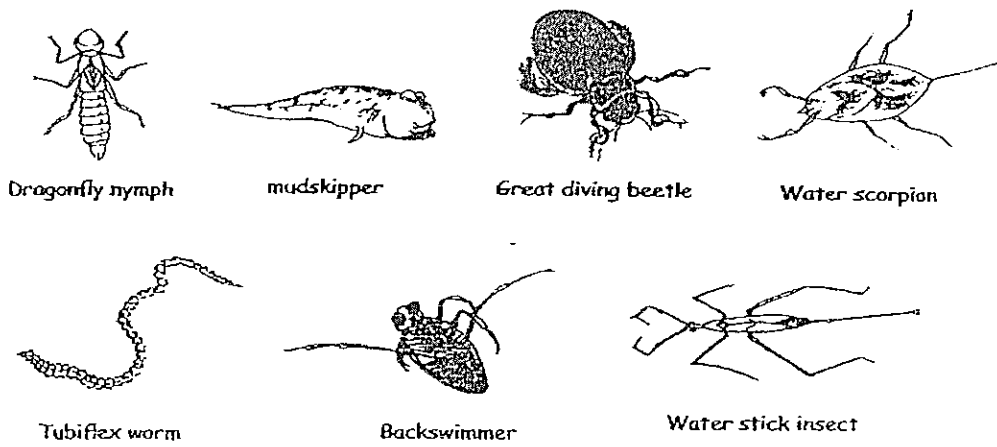

| | | | | |
|-----|-------------|------------------------------------|-----------------|--------------------------------------|
| (1) | Gills | Mudskipper Dragonfly nymph | Air bubbles | Great Diving beetle Backswimmer |
| (2) | Moist skin | Tubifex worms Mudskipper | Breathing Tubes | Water scorpion Water stick insect |
| (3) | Air bubbles | Great Diving beetle Backswimmer | Breathing Tubes | Water scorpion Water stick insect |
| (4) | Gills | Mudskipper Dragonfly Nymph | Breathing tubes | Water scorpion Water stick insect |

15. Which one of the following is not from a flower?

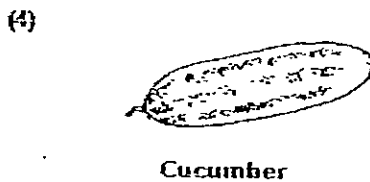
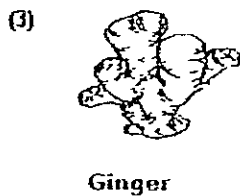
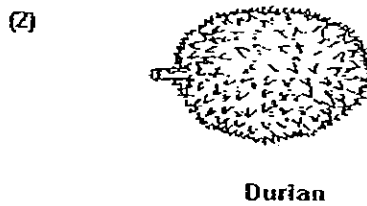
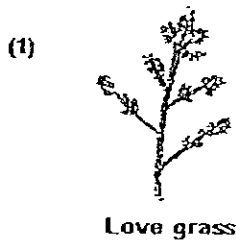

Go to page 10

METHODIST GIRLS' SCHOOL PRIMARY
SEMESTRAL ASSESSMENT 1, 2008
PRIMARY 6

SCIENCE
(BOOKLET A2)

NAME : _____ ()

CLASS : PRIMARY _____

| Booklet | Possible marks | Actual marks |
|---------|----------------|--------------|
| A | 60 | |
| B | 40 | |
| TOTAL | 100 | |

Total time for booklets A and B : 1 hour 45 minutes

Instructions to pupils

DO NOT TURN OVER THE PAGES UNTIL YOU ARE TOLD TO DO SO.

Follow all instructions carefully.

There are 30 questions in this booklet.

Answer all the questions.

16. Henry took a 50 ml syringe and filled it with air. She poked the syringe through the bottle cap and pushed all the air in the syringe into the empty bottle with a capacity of 250 ml. After that she sealed the bottle cap with a sticky tape to prevent the air from escaping. What is the volume of air in the bottle now?

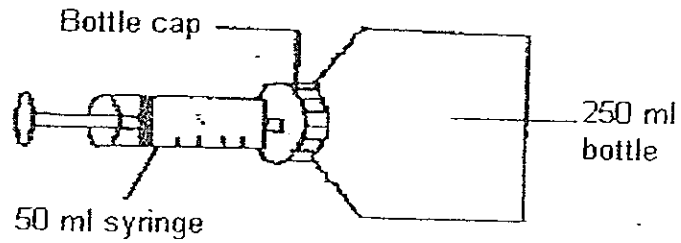

- (1) 50 ml
- (2) 200 ml
- (3) 250 ml
- (4) 300 ml

Go to page 11

17. Study the classification table below. Su-Ann was told to select the best materials for making boots and helmets for firemen. She was also told that the same material could not be used to make both items.

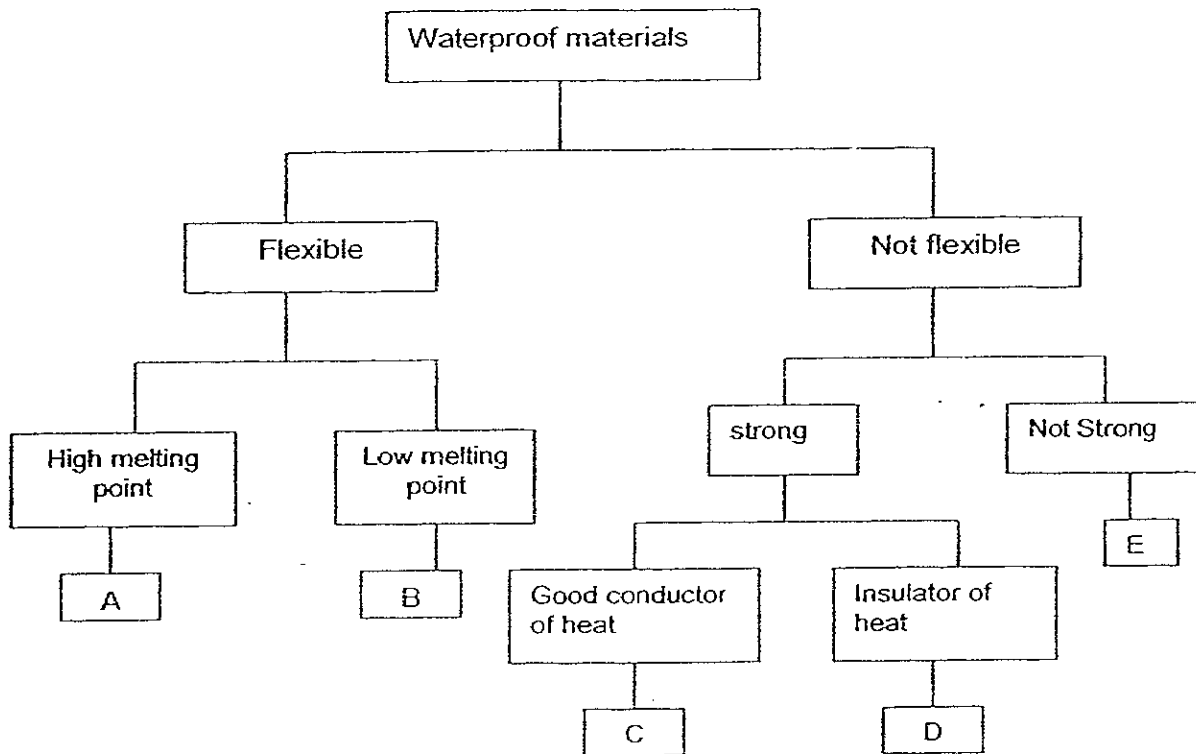

Which materials are the best for making boots and helmets for firemen?

| | Boots | Helmets |
|-----|-------|---------|
| (1) | A | C |
| (2) | B | D |
| (3) | D | E |
| (4) | A | D |

Go to page 12

18. The diagram below shows a water cycle.

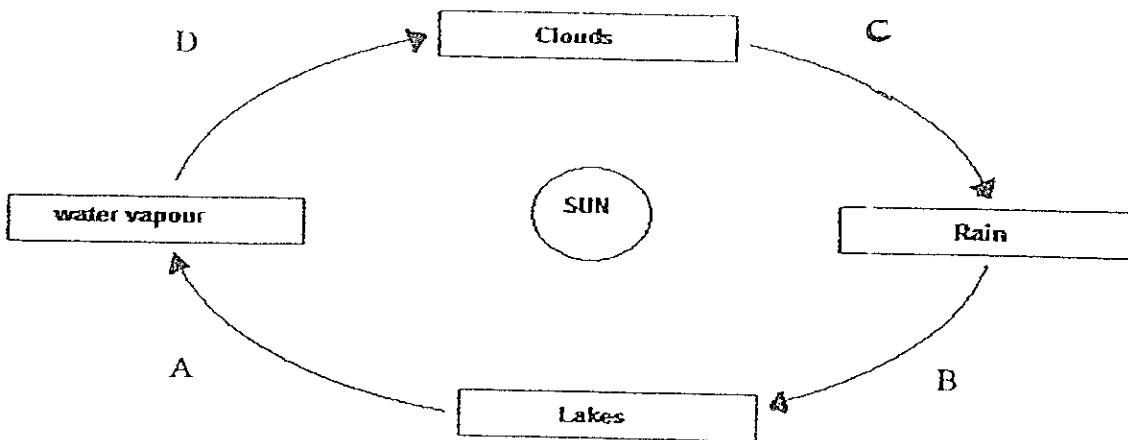

Which of the following correctly represents evaporation and condensation?

| | Evaporation | Condensation |
|-----|-------------|--------------|
| (1) | A | B |
| (2) | A | D |
| (3) | D | C |
| (4) | B | D |

19. Which of the following arrows show correctly the direction in which magnet X would move?

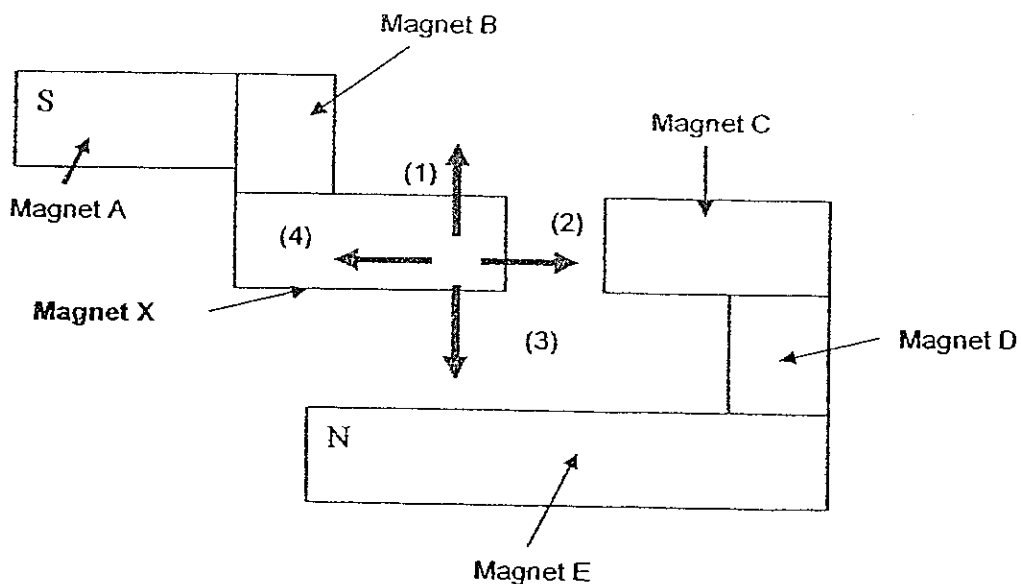

Go to page 13

20. Doris places two dishes of water in a dark room.

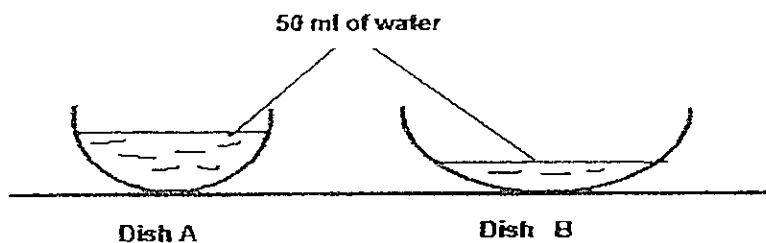

Which graph below shows the change in the amount of water in the dishes?

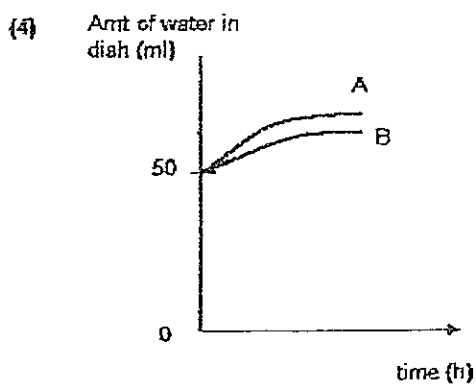
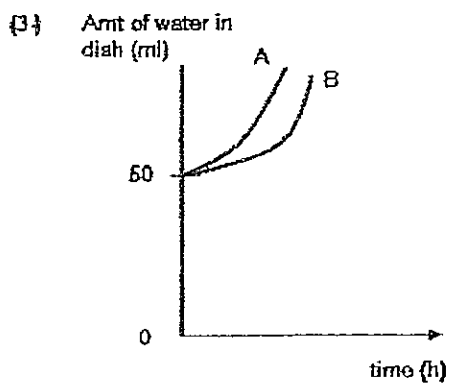
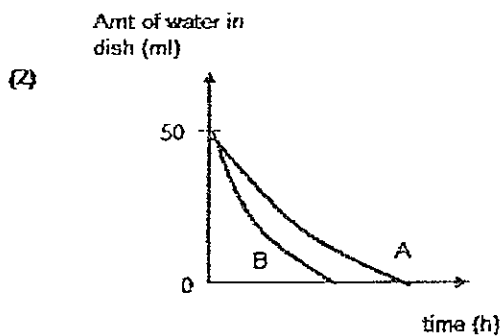
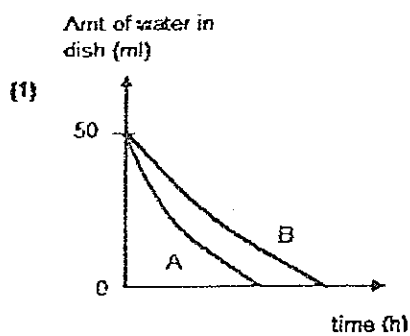

Go to page 14

21. Study the circuit below.

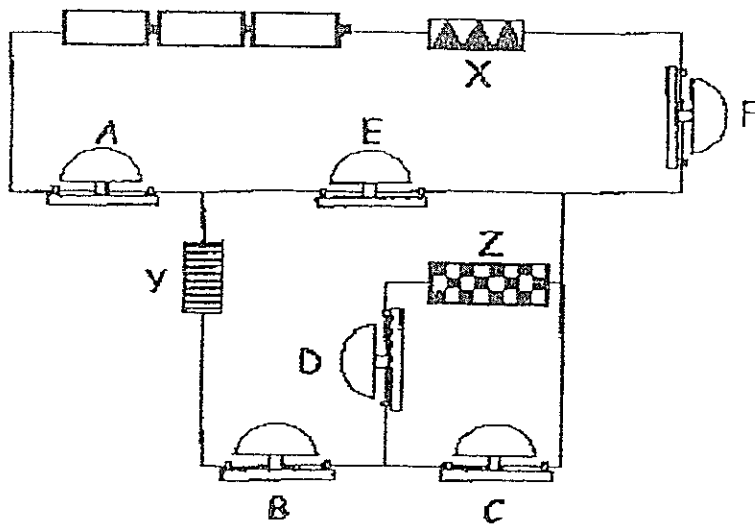

Given that only bells A, E and F rang, which of the following conclusions can you draw?

- (1) Y and Z are not electrical conductors.
- (2) X, Y and Z are electrical conductors.
- (3) Z is not an electrical conductor.
- (4) X and Y are electrical conductors.

22. In the diagram below, a ball is rolled towards a boy. In which direction does friction act?

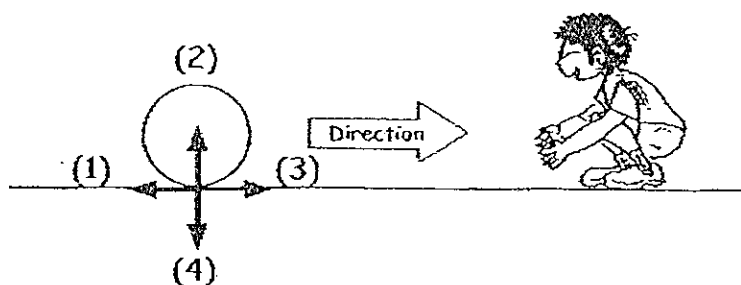

Go to page 15

23. May used the set-up shown below to test if a material can conduct electricity.

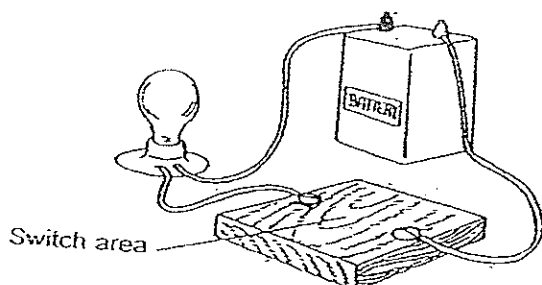

The results of the experiment are shown in the table below.

| Switch material | Light produced by the above circuit | | | |
|-----------------|-------------------------------------|---------|-------------|-------------|
| | Trial 1 | Trial 2 | Trial 3 | Trial 4 |
| Steel nail | Bright | Bright | Bright | Bright |
| Aluminum foil | Bright | Dim | Dim | Bright |
| Copper ring | Very bright | Bright | Very bright | Very bright |
| Pencil lead | Dim | Bright | Dim | Dim |

Based on the above data, arrange the materials according to their electrical conductivity, from the weakest to the strongest.

- (1) Steel nail, pencil lead, aluminum foil, copper ring
- (2) Copper ring, steel nail, aluminum foil, pencil lead
- (3) Pencil lead, aluminum foil, steel nail, copper ring
- (4) Copper ring, aluminum foil, steel nail, pencil lead.

Go to page 16

24. The diagram below shows a windlass. What can be done to the machine so that the least amount of force is required to lift the load?

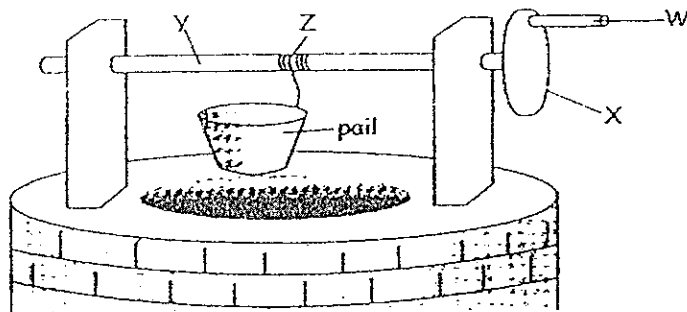

- A : Increase the length of W
- B : Increase the diameter of X
- C : Decrease the diameter of Y
- D : Decrease the length of the rope Z

- (1) A and B only
- (2) B and C only
- (3) A, B and C only
- (4) All of the above

Go to page 17

25. Kelly hung various loads on 2 springs, Spring X and Spring Y. She measured the corresponding lengths of the springs. She recorded her results and plotted the graph below.
Based on the graph, which of the following answer is true?

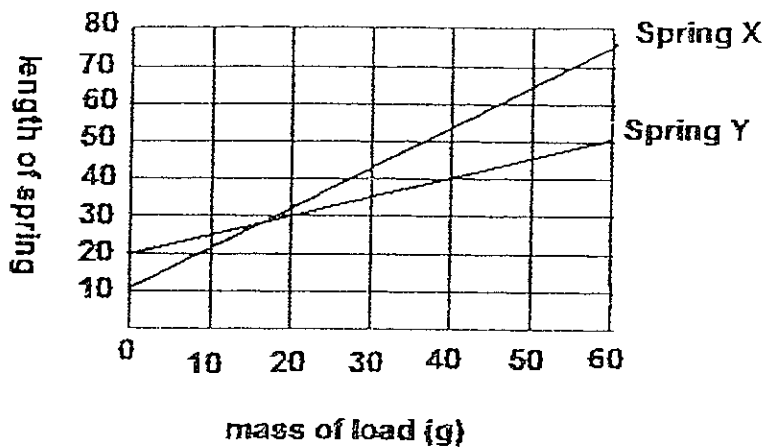

- (1) Spring X has a longer original length than Spring Y.
 - (2) Spring Y has a longer original length than Spring X.
 - (3) Spring X is made of a stronger material than Spring Y.
 - (4) Spring Y always extends more than Spring X when a load is hung from it.
26. Angela went to the playground and decided to play on the slide. She came down the slide and landed with a thud.



Which of the following energy conversions took place for the above situation?

- (1) Chemical potential energy \rightarrow Kinetic energy \rightarrow heat energy
- (2) Gravitational potential energy \rightarrow sound energy \rightarrow kinetic energy + heat energy
- (3) Gravitational potential energy \rightarrow kinetic energy \rightarrow sound energy + heat energy
- (4) Chemical potential energy \rightarrow sound energy \rightarrow heat energy + kinetic energy

Go to page 18

27. The diagram below shows how electricity is generated at a power station. The forms of energy that are used in the generation of electricity are represented by A, B, C and D.

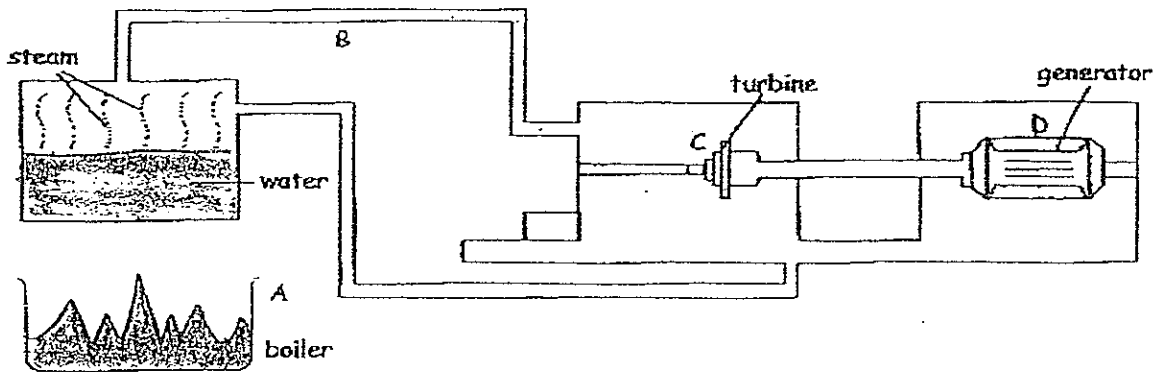

Which one of the following shows correctly the forms of energy that A, B, C and D represent?

| | A | B | C | D |
|-----|---------|---------|-----------|------------|
| (1) | Heat | Kinetic | Kinetic | Potential |
| (2) | Kinetic | Heat | Kinetic | Electrical |
| (3) | Kinetic | Heat | Potential | Kinetic |
| (4) | Heat | Kinetic | Kinetic | Electrical |

Go to page 19

28. Jessie set up the experiment as shown below.

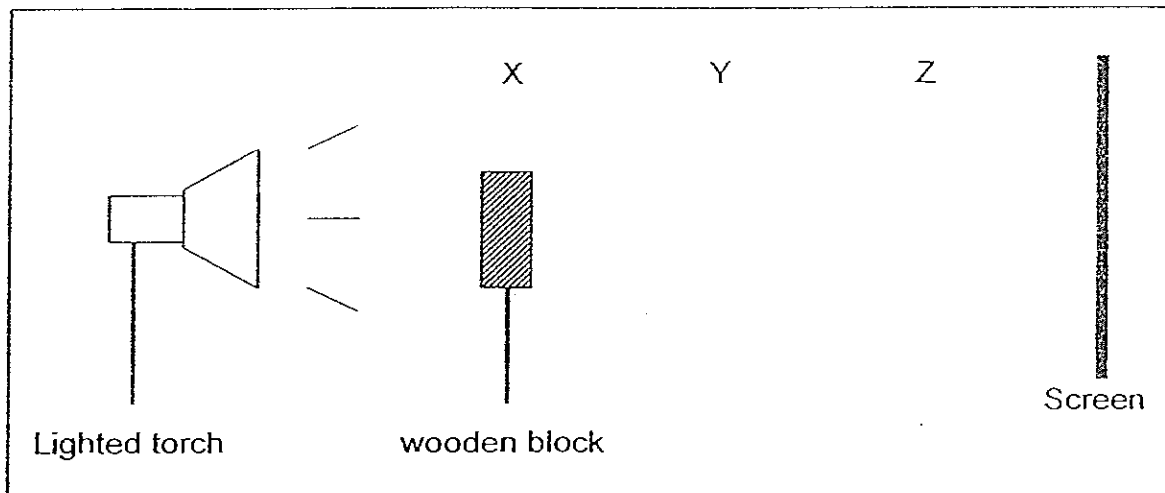

Jessie placed the wooden block at positions X, Y and Z which are at different distances from the screen. At each position, she measured the length of the shadow cast on the screen. Which one of the following shows correctly the length of the shadows Jessie recorded for positions X, Y and Z?

| | Length of shadow at X (cm) | Length of shadow at Y (cm) | Length of shadow at Z (cm) |
|-----|------------------------------|------------------------------|------------------------------|
| (1) | 20 | 18 | 11 |
| (2) | 18 | 11 | 20 |
| (3) | 11 | 18 | 20 |
| (4) | 18 | 18 | 18 |

Go to page 20

29. 2 identical metal balls were placed in beakers P and Q which were filled with hot boiling water. Which of the following statements are correct?

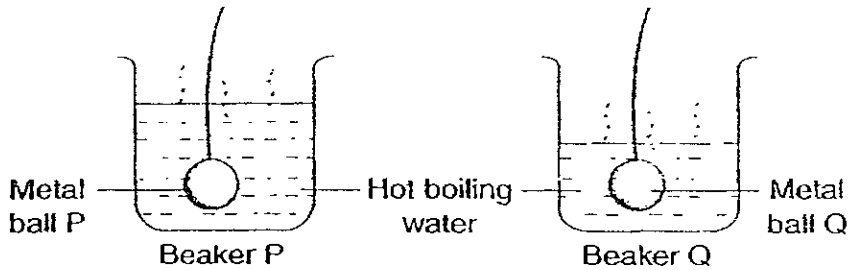

- A : Heat from the hot water is transferred to the metal balls.
B : Both metal balls would expand after a while.
C : Metal ball P gained heat faster than metal ball Q.
D : The water in beaker P lost heat faster than the water in beaker Q.

- (1) A and B only
(2) C and D only
(3) A and C only
(4) B and D only

Go to page 21

30. Four different metals A, B, C and D were used to make 3 sets of rings as shown in the diagrams below. All the sets of rings were similar except for the material used.

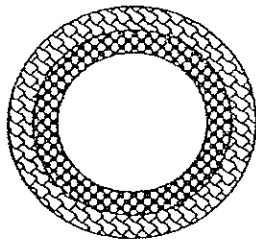



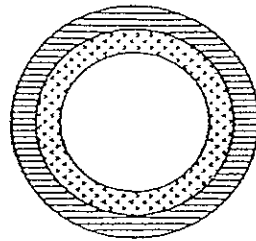

Set 1

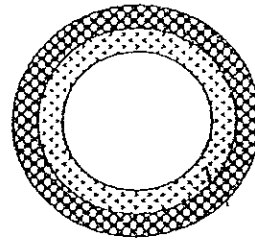

Set 2



Set 3

| Legend for cross-section of rings | | | |
|---|---|---|--|
|  |  |  |  |
| Metal A | Metal B | Metal C | Metal D |

At 25°C, all the inner rings of each set could just fit into the outer ring and still be able to pull out with some effort. The sets of rings were heated evenly from 25°C to 50°C and the observation was recorded in the table below.

| At 50°C | | |
|----------------------------------|--|---|
| Set 1 | Set 2 | Set 3 |
| Ring B fell out of ring A easily | Ring C could not be pulled out even with great effort. | Ring C could just fit into outer ring and still be able to pull out with some effort. |

Based on the above observations, which metal A, B, C or D expanded the most when heated?

- (1) A
- (2) B
- (3) C
- (4) D

Go to Section B

END OF SECTION A

METHODIST GIRLS' SCHOOL PRIMARY
SEMESTRAL ASSESSMENT 1, 2008
PRIMARY 6

SCIENCE
(BOOKLET B)

NAME : _____ ()

CLASS : PRIMARY _____

16 questions
40 marks

Total time for Booklet A and B : 1 hour 45 minutes

Instructions to pupils

DO NOT TURN OVER THE PAGES UNTIL YOU ARE TOLD TO DO SO.
Follow all instructions carefully.
There are 30 questions in this booklet.
Answer all the questions.

Section B : 40 marks

Read the questions carefully and write your answers in the spaces provided.

31. Study the following classification chart.

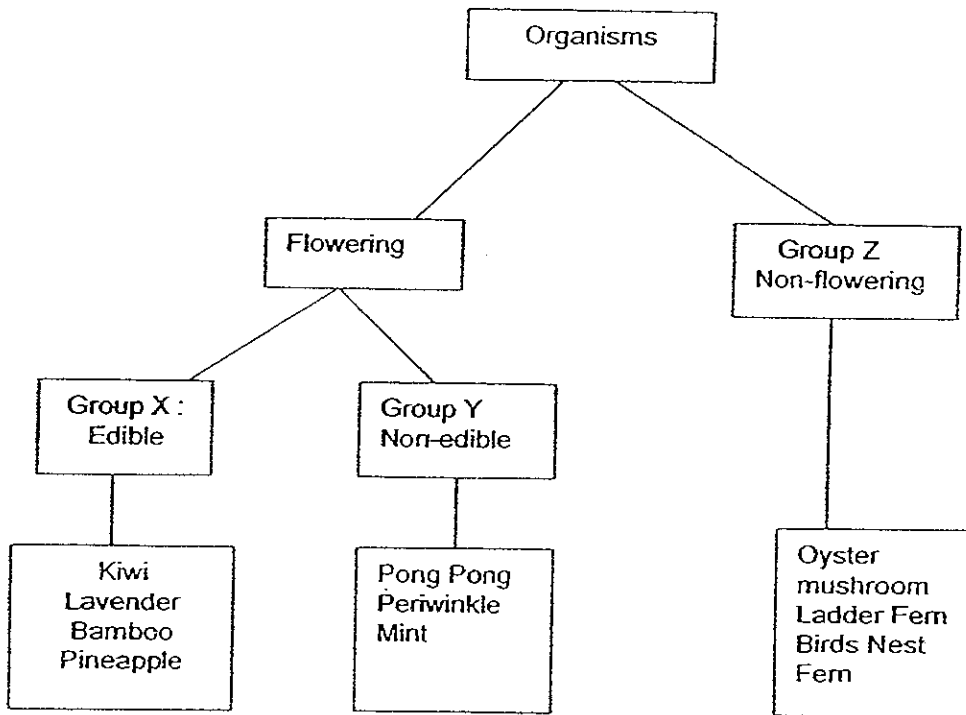

(a) Which organism has been wrongly classified. (1m)

(b) In which group should you put "Allamanda"? (1m)

Go to page 23

32. The diagram below shows an open fruit.

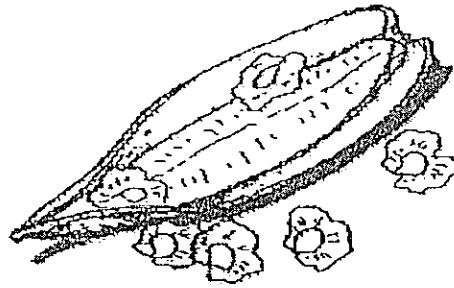

(a) Study the fruit above. How are the seeds dispersed? (1m)

(b) State two characteristics that the seed have which allow them to be dispersed that way. (1m)

33. Roby planted a bean each in five pots. They were placed under different conditions for three days as shown in the table below. The results were recorded in the table below.

| Pot | Air | Water | Light | Temperature (°C) | Result |
|--------------|-----|-------|-------|------------------|---------------------|
| A | ✓ | ✓ | x | 25 | Root and shoot grew |
| B | ✓ | ✓ | ✓ | 5 | No change observed |
| C | x | ✓ | ✓ | 25 | No change observed |
| D | ✓ | ✓ | ✓ | 25 | Root and shoot grew |
| E | ✓ | x | ✓ | 25 | No change observed |

(a) What can you conclude about the conditions for the bean to germinate? (1m)

(b) What would happen to the 5 bean seeds after 3 weeks if left in the same conditions in each pot and why? (2m)

34. The diagram shows the different stages in the life cycle of a flowering plant.

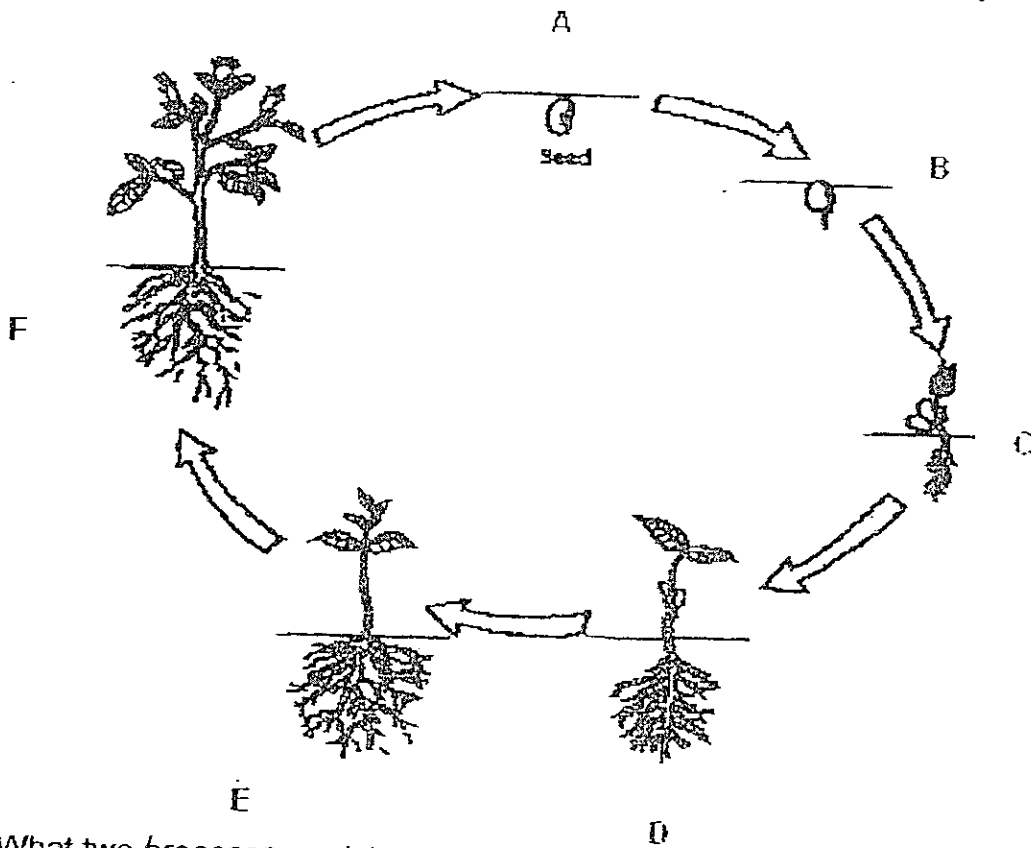

- (a) What two processes must occur at stage F for the plant to progress to Stage A? (1m)
-
- (b) What happens to the seed leaves at Stage C as the seedling grows taller? (1m)
-
- (c) Very often, a seedling struggles to grow as it competes for resources. What must an adult plant do to increase its chances of having many healthy seedlings? (1m)
-

Go to page 25

35. Study the passage below.

Mr Samy owns a corn farm in Australia. One summer, countless rootworms plagued his crops and caused him to lose acres of fertile land. He began rearing ducks and to his surprise, they feasted on the rootworms, solving his distress. Thanks to the ducks, Mr Samy can now recoup his losses and start a new corn crop.

(a) Construct a food chain occurring in Mr Samy's corn farm. (1m)

(b) Why should ducks be used to control the rootworms population instead of pesticides? (1m)

36. The diagram below shows the conditions found in a pond community. In December, there were torrential downpour and the forest next to the pond experience soil erosion. Large amounts of minerals, nutrients and mud were washed into the pond.

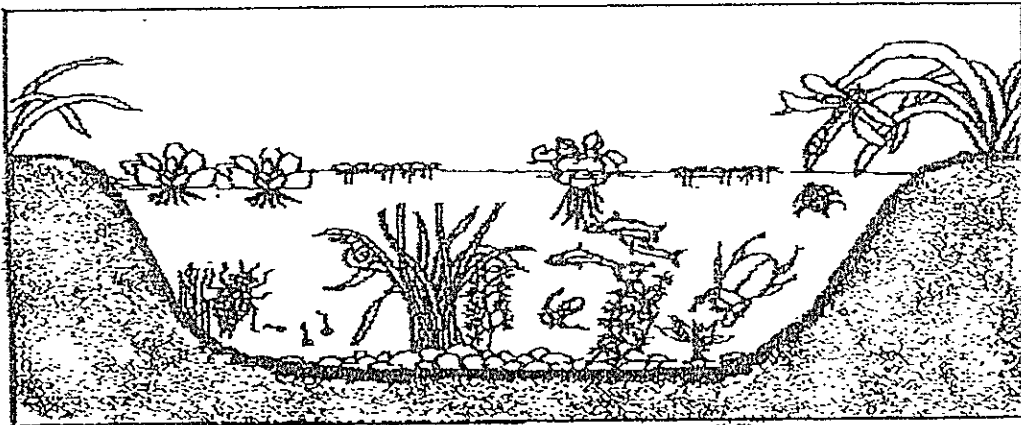

(a) What can be observed after a month? (1m).

In the pond, the _____ and _____ would have died.

(b) Explain why the situation in (a) occurred? (2m)

Go to page 26

37. Study the food web below.

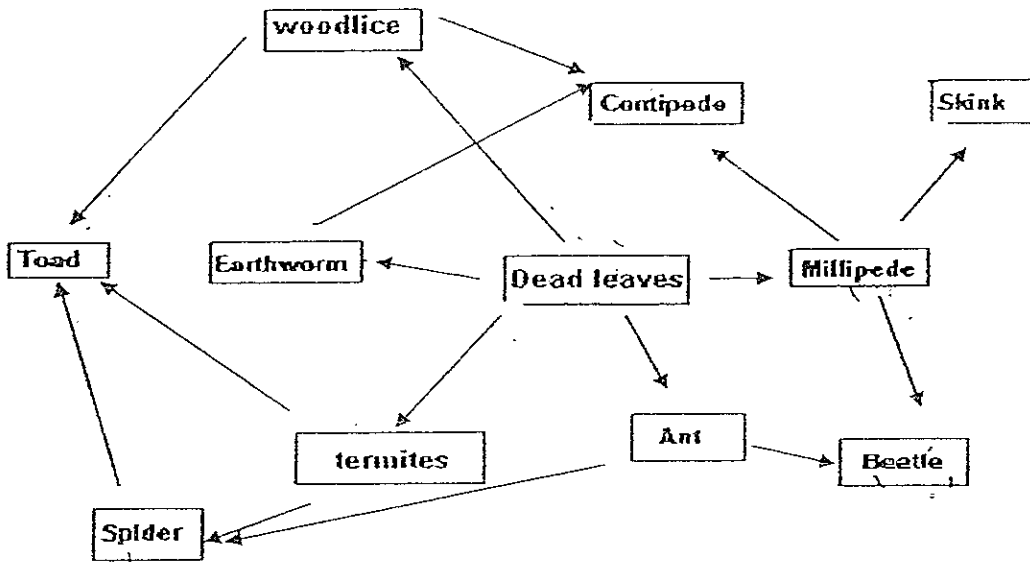

(a) Describe two conditions of this habitat. (1m)

(b) Write out one of the food chains with 4 organisms. (1m)

(c) What would happen if there was an increase in the ant population?
Explain your answer. (1m)

Go to page 27

38. Brenda carried out an experiment on plants making food. She enclosed a leaf of a plant in a flask as shown in the diagram below. The plant was then left in the dark for two days. Then it was placed in the sunlight for 8 hours.

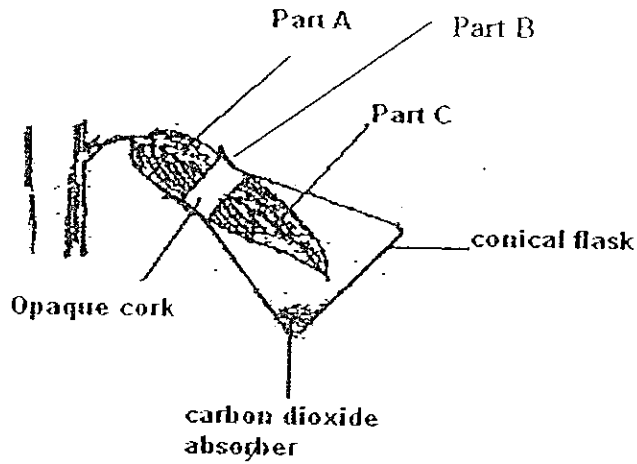

- (a) Study the diagram carefully, Which part of the leaf was the control? ($\frac{1}{2}$ m)
-
- (b) After 8 hours, the leaf was then plucked and tested for starch. Label the colours of the 3 sections of the leaf after the starch test in the diagram below. ($1\frac{1}{2}$ m)

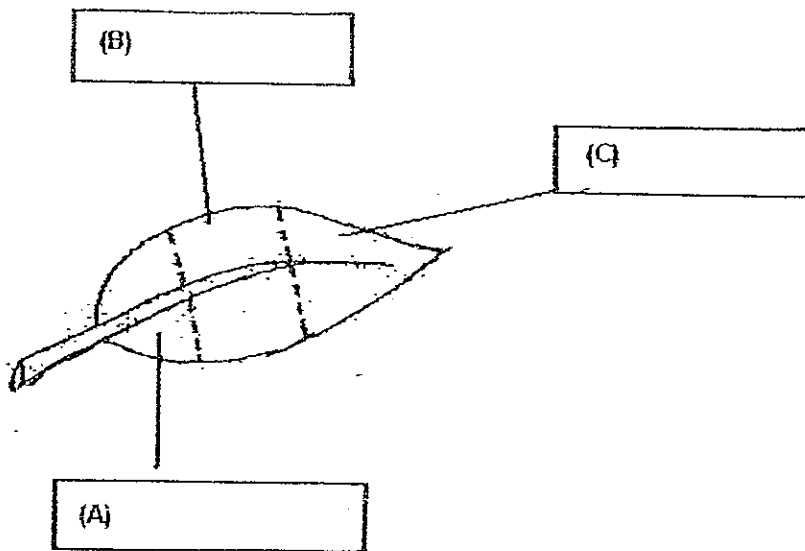

Go to page 28

Go to page 28

39. Sue heated some water in a beaker at room temperature until it boiled. It was then left on the kitchen table to cool. She recorded her results in the graph as shown below.

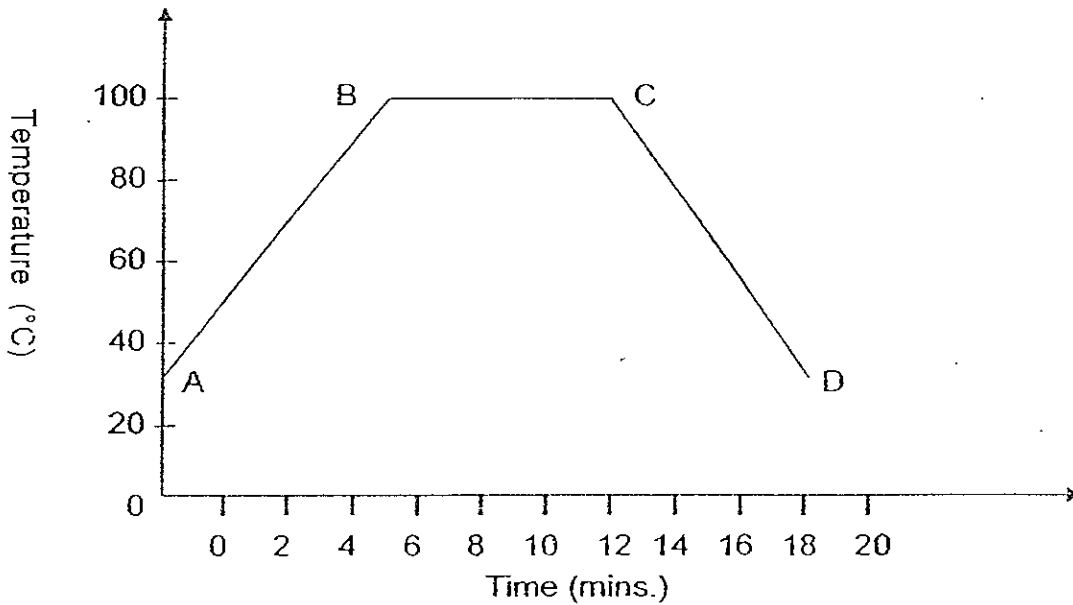

Below are four sentences based on her results. Indicate whether each of the statements is true, not true or not possible to tell by putting a tick (✓) in the correct column. (2m)

| Statements | True | Not True | Not possible to tell |
|---|------|----------|----------------------|
| (i) The flame was turned off after 12 minutes | | | |
| (ii) Water only evaporate during period CD. | | | |
| (iii) The room temperature is 40°C. | | | |
| (iv) The rate of evaporation is higher during BC than CD. | | | |

Go to page 29

40. Study the setup below. Three similar magnets were glued on the underside of a lever but they were unable to lift load A, which is 50 g.

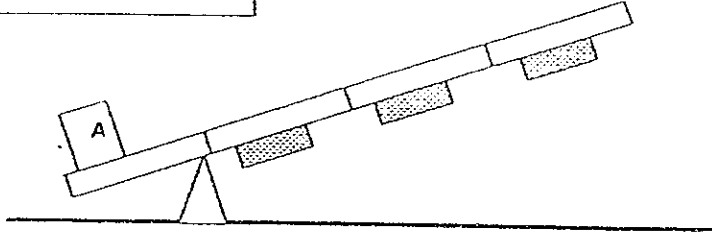
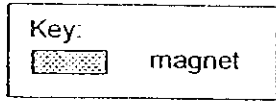

A magnet, B, was placed under the lever and the following was observed.

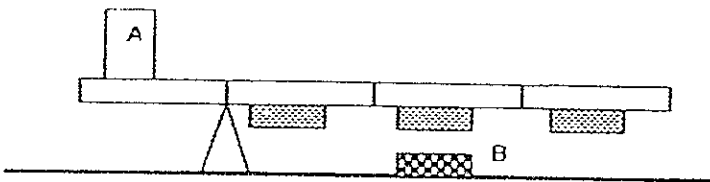

- (a) Give a reason for your observation (1m)

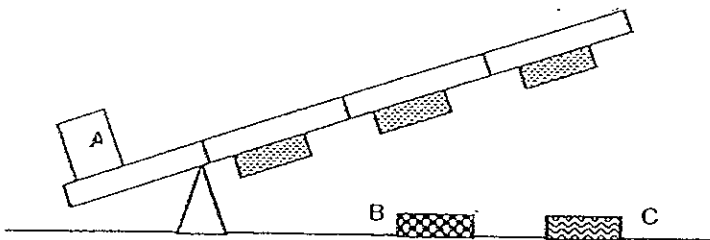

- (b) Explain why load A was not lifted up when magnet C was placed under the lever, even though magnet B was still present. (1m)

Go to page 30

41. Danny performed an experiment to investigate how the extension of a spring is affected by the mass hung from it.
- He hung different masses onto Spring X, Y and Z and measured the extension of each spring. Then he plotted the results of his experiment in the graph below.

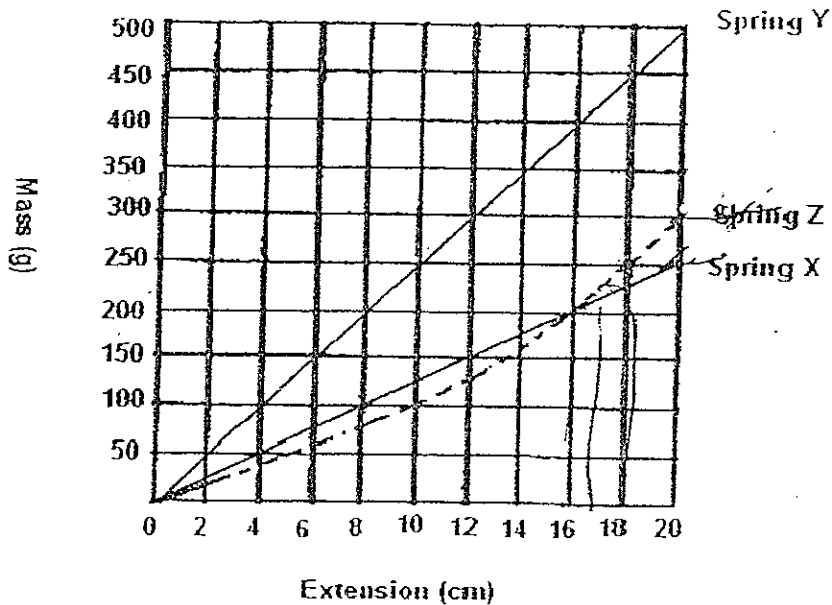

- (a) In the graph above, which spring(s) is the extension directly proportional to the mass hung on it? (1m)
-
- (b) Based on the graph, what is the extension of Spring Y when a 700 g mass is hung from it? (1m)
-
- (c) Given that the original length of all the 3 springs are the same, at what mass would Spring Z become longer than Spring X? (1m)
-

Go to page 31

42. Sandy wanted to sell her old stuffed toys at a funfair at the top of the hill. She filled her wagon with some of her stuffed toys and dragged it up the slope as shown below.



- (a) Name two types of forces that are acting on the wagon as Sandy climbs the hill. (1m)

- (b) Describe the energy changes when Sandy pulls the wagon from the bottom of the hill to the top of the hill. (1m)



- (c) The law of conservation of energy states, "Energy cannot be created or destroyed. It can be changed from one form to another." With reference to this, how do herbivores obtain energy indirectly from the sun? (2m)

Go to page 32

43. Study the electrical circuit below.

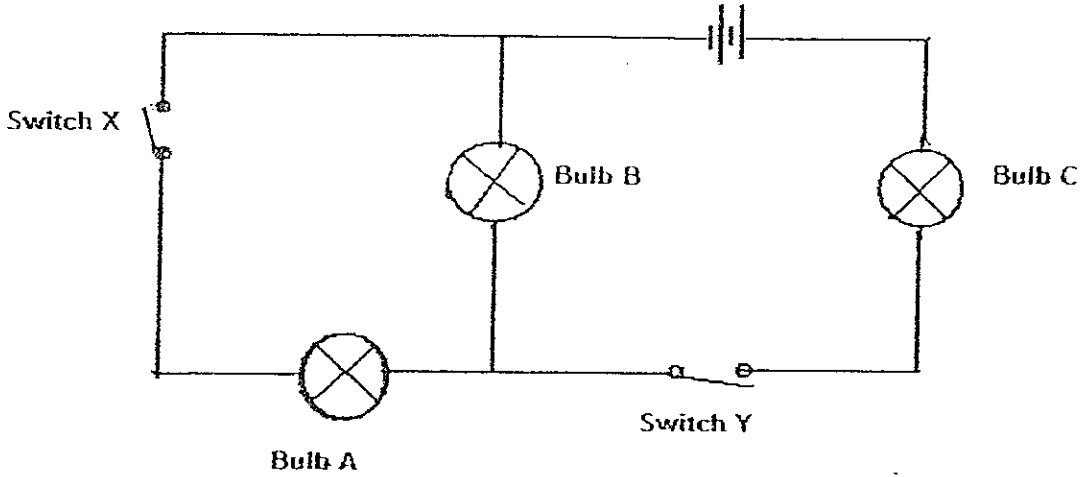

(a) Put a tick (\checkmark) in the boxes to indicate if the bulb lights up or a cross (x) in the boxes to indicate if the bulb does not light up. (1½m)

| Change in circuit orientation | Resulting bulbs that light up | | |
|--|-------------------------------|--------------|---|
| | A | B | C |
| (i) Switch X is open and Switch Y is closed. | | \checkmark | |
| (ii) Switch X is closed and Switch Y is open | x | | x |

(b) Draw wires to connect the three batteries and the bulb to form an electrical circuit in a way which allows the bulb to shine the brightest. (1m)

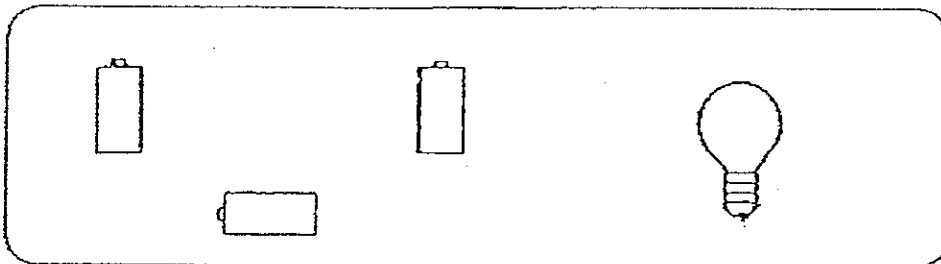

Go to page 33

44. Kerry designed a circuit card using some wires and paper clips A, B, C, D and E as shown below.

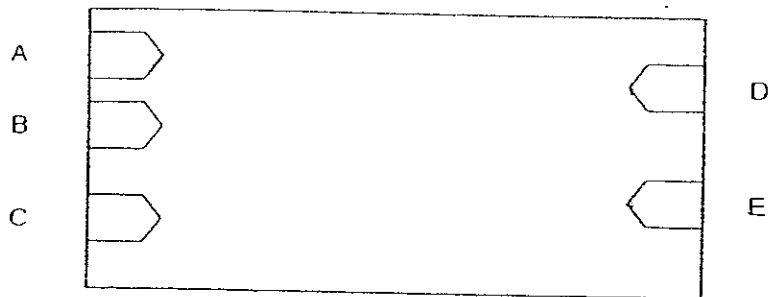

The following results are obtained when a circuit tester is used on the card.

| Clips tested | Does the bulb light up |
|--------------------|------------------------|
| A and B | No |
| B and C | No |
| C and A | No |
| A and D | Yes |
| B and D | Yes |
| C and D | No |
| A and E | Yes |
| B and E | Yes |
| C and E | No |
| D and E | Yes |

- (a) Draw only 2 wires on the circuit card above to show how they are connected to get the results shown above. (1½m)
- (b) Kerry's teacher told him that it is not advisable to use insulated paper clips for this experiment. Why is it so? (1m)

Go to page 34

45. Tom is playing with a catapult. He pulled the rubber band back and releases it. The pebble flew and hit a tree and fell with a thud.

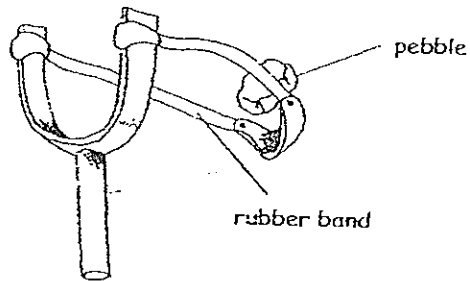

- (a) State the energy conversion when the stretched rubber band is released? (1m)

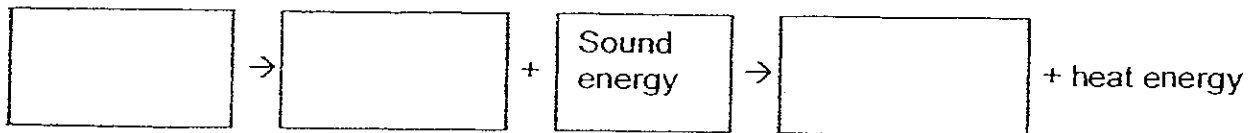

- (b) What can Tom do so that he could send the pebble further? (1m)

Go to page 35

46. Jenny set up the experiment shown using three identical insulated cups. This diagram shows the apparatus at the start of the experiment.

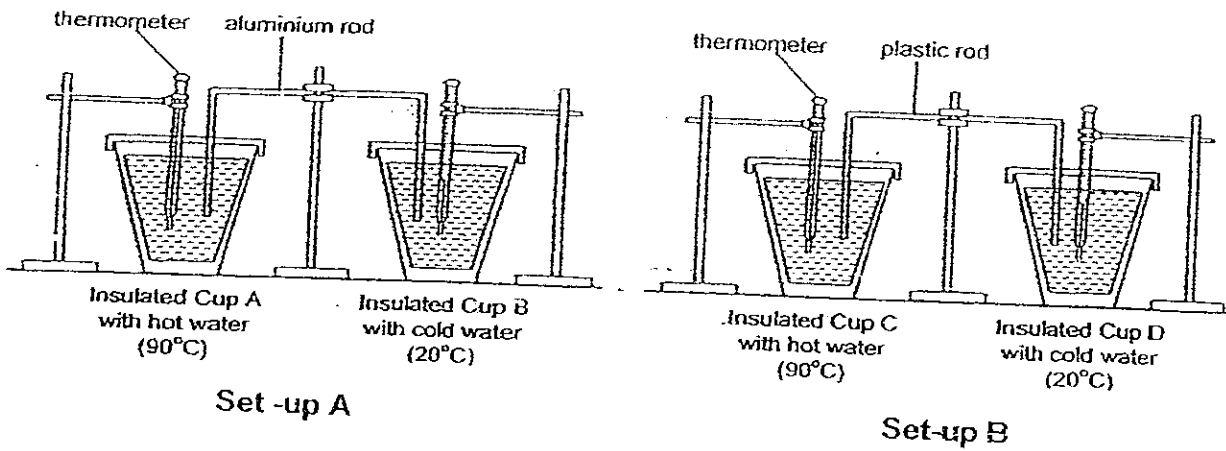

- (a) Twenty minutes after the start of the experiment, Jenny recorded the temperature of the water in each cup. In the boxes below, arrange the cups according to the temperature of the water in them from the hottest to the coolest. (1m)

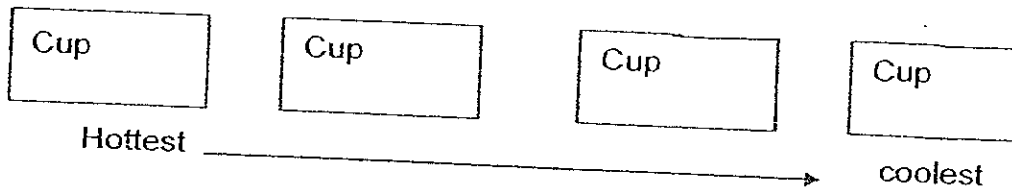

- (b) What is Jenny trying to find out? (1m)

END OF PAPER

HAVE YOU CHECK YOUR PAPERS?

MGS Primary School
Primary 6 Science SA1 Exams (2008)

Answer Keys

| Qo. | Ans |
|-----|-----|
| 1 | 2 |
| 2 | 3 |
| 3 | 4 |
| 4 | 3 |
| 5 | 2 |
| 6 | 4 |
| 7 | 4 |
| 8 | 3 |
| 9 | 4 |
| 10 | 1 |

| Qn no. | Ans |
|--------|-----|
| 11 | 3 |
| 12 | 1 |
| 13 | 3 |
| 14 | 2 |
| 15 | 3 |
| 16 | 3 |
| 17 | 4 |
| 18 | 2 |
| 19 | 2 |
| 20 | 2 |

| Qn no | Ans |
|-------|-----|
| 21 | 1 |
| 22 | 3 |
| 23 | 3 |
| 24 | 2 |
| 25 | 2 |
| 26 | 3 |
| 27 | 4 |
| 28 | 1 |
| 29 | 1 |
| 30 | 1 |

- 31a. Mint (b) Group Y
- 32a. By wind
 32b. It is light and has wing-like structures.
- 33a. Beans need water, warmth and air to germinate.
 33b. The bean seeds in pots B, C and E will remain the same while the bean seed in pot A will die. However, the bean in pot D will be healthy and strong. For a plant to grow well after germination it needs light, air and water to photosynthesize.
- 34a. Fertilization and Pollination.
 34b. It will drop off.
 34c. It must disperse its seeds as far as possible to reduce chances of overcrowding.
- 35a. Crops → rootworms → ducks
 35b. Pesticides not only kill rootworms, but also might add on to air pollution.
- 36a. Plants and animals.
 36b. Without sunlight the totally submerged plants cannot photosynthesize which cause them to die from a lack of food. In turn aquatic animals cannot get enough oxygen and would die.
- 37a. It is damp and dark.
 37b. Dead leaves → Ant → Spider → Toad
 37c. There would be a sharp decrease of dead leaves in the habitat and animals like termites, millipede and the earthworm will have less food to eat and their population will slowly decrease and so will their predators. The beetle spider and toad will increase as there is more food for them to consume.

38a. Part A

38b. A : Dark blue or dark purple

B : brownish

C : brownish

39(i) True (ii) Not true (iii) Not true (iv) True

40a. The force of attract between Magnet B and the middle magnet pulls the lever towards B.

40b. Magnet C is probably a much stronger magnet than Magnet B, repelling the other magnets, therefore the magnets were still unable to lift load A.

41a. Spring Y and Spring X

41b. 28cm

41c. 200g

42a. Gravitational force and frictional force.

42b. Chemical potential energy \longrightarrow kinetic energy + sound \longrightarrow gravitational potential energy.

42c. Plants during the process of photosynthesis, convert the light from the sun to chemical potential energy in food.

43a(i). A : \times B : \checkmark C : \checkmark

(ii) A : \times B : \times C : \times

43b.

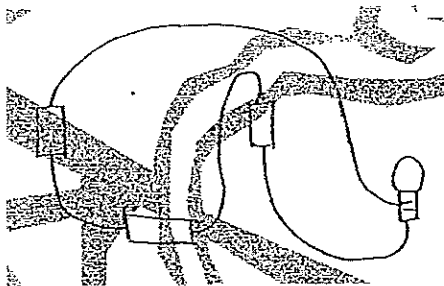

44a.

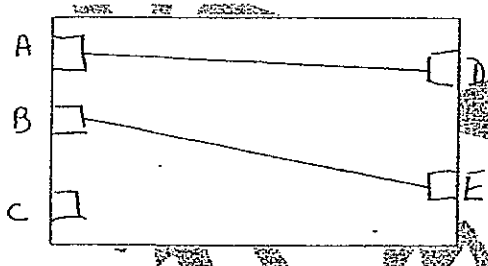

44b. Insulated paper clips do not conduct electricity and the experiment would not work.

- 45a. Elastic potential energy \longrightarrow kinetic energy + sound energy \longrightarrow gravitational potential + heat energy.
- 45b. He could stretch the rubber band even further
- 46a. C, A, B, D
- 46b. Jenny is trying to find out which material, aluminum or plastic is a better insulator of heat.